

MacUser

Guide to Connectivity

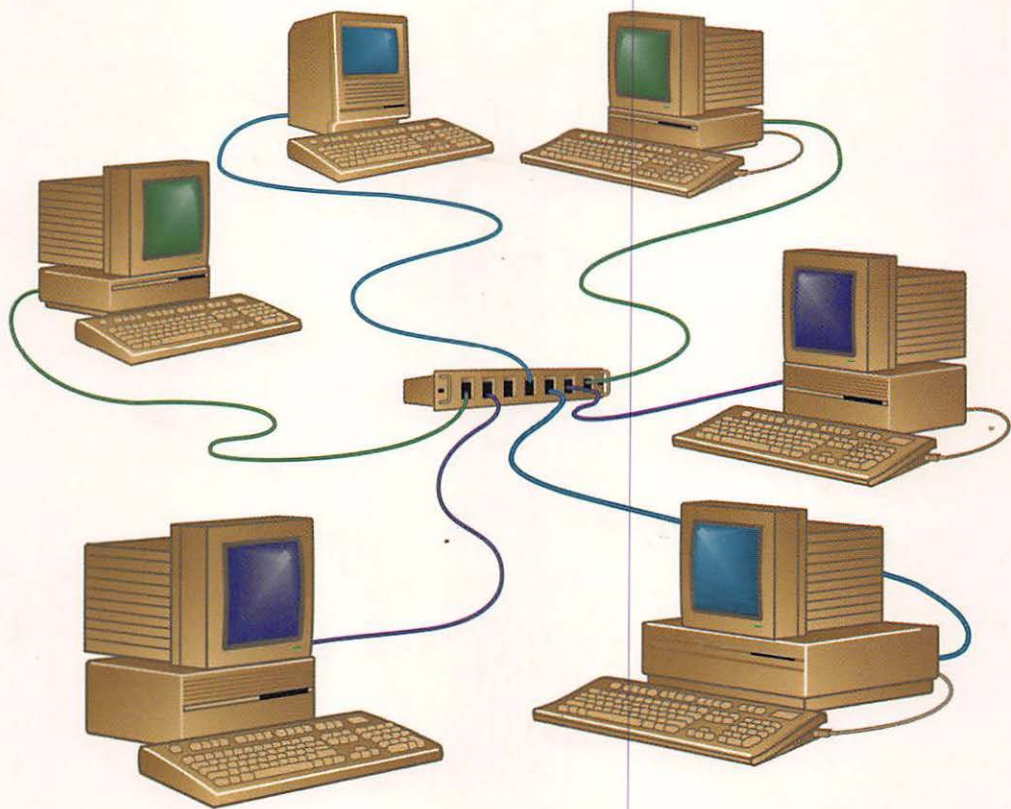

John Rizzo

Foreword by Henry Bortman, technical editor

MacUser technical editor John Rizzo tackles the full spectrum of connectivity. Discover scores of practical, lab-tested solutions covering virtually every scenario in the vast world of Macintosh information exchange from laptops to mainframes.

CLOSEOUT BOOK

829001

8559410089 2

BARGAIN COMP BKS1

10/96

503321

483

COMPUSA

9.99

Price

34

MacUser Guide to Connectivity

MacUser

MacUser Guide to Connectivity

John Rizzo



Ziff-Davis Press
Emeryville, California

Development Editor	Melinda E. Levine
Copy Editor	Sandra Horwich
Technical Reviewer	Henry Bortman
Project Coordinator	Ami Knox
Proofreader	Vanessa Miller
Cover Design	Megan Gandt and Ken Roberts
Book Design	Paper Crane Graphics
Technical Illustration	Cherie Plumlee Computer Graphics & Illustration
Screen Graphics Editor	Dan Brodnitz
Word Processing	Howard Blechman and Cat Haglund
Page Layout	Kevin Shafer & Associates, Bruce Lundquist, and M.D. Barrera
Indexer	David Heiret

This book was produced on a Macintosh IIx, with the following applications: FrameMaker[®], Microsoft[®] Word, MacLink[®] Plus, Aldus[®] FreeHand[™], Adobe Photoshop[™], and MicroFrontier's Color It![™].

Ziff-Davis Press
 5903 Christie Avenue
 Emeryville, CA 94608

Copyright © 1993 by Ziff-Davis Press. All rights reserved.

MacUser is a registered trademark of Ziff Communications Company. Ziff-Davis Press, ZD Press, and MacUser Guide To are trademarks of Ziff Communications Company.

All other product names and services identified throughout this book are trademarks or registered trademarks of their respective companies. They are used throughout this book in editorial fashion only and for the benefit of such companies. No such uses, or the use of any trade name, is intended to convey endorsement or other affiliation with the book.

No part of this publication may be reproduced in any form, or stored in a database or retrieval system, or transmitted or distributed in any form by any means, electronic, mechanical photocopying, recording, or otherwise, without the prior written permission of Ziff-Davis Press, except as permitted by the Copyright Act of 1976 and except that program listings may be entered, stored, and executed in a computer system.

THE INFORMATION AND MATERIAL CONTAINED IN THIS BOOK ARE PROVIDED "AS IS," WITHOUT WARRANTY OF ANY KIND, EXPRESS OR IMPLIED, INCLUDING WITHOUT LIMITATION ANY WARRANTY CONCERNING THE ACCURACY, ADEQUACY, OR COMPLETENESS OF SUCH INFORMATION OR MATERIAL OR THE RESULTS TO BE OBTAINED FROM USING SUCH INFORMATION OR MATERIAL. NEITHER ZIFF-DAVIS PRESS NOR THE AUTHOR SHALL BE RESPONSIBLE FOR ANY CLAIMS ATTRIBUTABLE TO ERRORS, OMISSIONS, OR OTHER INACCURACIES IN THE INFORMATION OR MATERIAL CONTAINED IN THIS BOOK, AND IN NO EVENT SHALL ZIFF-DAVIS PRESS OR THE AUTHOR BE LIABLE FOR DIRECT, INDIRECT, SPECIAL, INCIDENTAL, OR CONSEQUENTIAL DAMAGES ARISING OUT OF THE USE OF SUCH INFORMATION OR MATERIAL.

ISBN 1-56276-056-4
 Manufactured in the United States of America

10 9 8 7 6 5 4 3 2

In memory of Salvatore L. Rizzo, Sr., whose hard work and creativity continue to inspire those who knew him.

■ Contents at a Glance

Foreword	xvii
Introduction	xxi
Chapter 1: Built-in Connectivity	1
Chapter 2: Sharing Files with PCs	9
Chapter 3: Telecommunications	33
Chapter 4: The Traveling Mac	57
Chapter 5: Network Plumbing	77
Chapter 6: Connecting LANs: Internets	105
Chapter 7: Network Services	129
Chapter 8: The UNIX Connection	163
Chapter 9: The VAX Connection	187
Chapter 10: Mainframe Connections	209
Chapter 11: Database Connectivity	231
Chapter 12: Network Management and Troubleshooting Tools	253
Chapter 13: Networks across the Globe	285
Chapter 14: Collaboration, the Next Step	311
Appendix: Connectivity MiniFinder	329
Index	357

■ Table of Contents

Foreword	xvii
Introduction	xxi
<hr/>	
Chapter 1: Built-in Connectivity	1
No Mac Is an Island	3
Free Connectivity	3
Connectivity for the Rest of Us	4
The Many Operating Systems of Mac	6
<hr/>	
Chapter 2: Sharing Files with PCs	9
Built In: Reading DOS Disks	10
Non-Network Connections to PCs	11
Sharing Disks	11
Serial Connections	14
Translating Files between a Mac and a PC	15
Applications That Translate	15
Translation Software	17
Running DOS on Your Mac	18
DOS via Software and Hardware	18
DOS via a Network	21
Mixing Macs and PCs on a Network	22
AppleTalk for PCs	23
Passports to Foreign LANs	24
Printing to PC Printers	26
One-on-One	27

Printer-Sharing Devices	28
LocalTalk for PC Printers	28
Printer Languages	29

Looking Ahead	31
----------------------	-----------

Chapter 3: Telecommunications	33
--------------------------------------	-----------

Built In: The Mac Modem Port	34
-------------------------------------	-----------

Choosing a Modem	35
-------------------------	-----------

An Alphabet Soup of Standards	36
Selecting a Modem Cable	38
Fax Modems	39
Network Modems	41

Understanding the Software	41
-----------------------------------	-----------

Terminal Emulation	43
Scripting	44
File Transfer	45
Compression Utilities	46

Exploring the World of On-Line Services	47
--	-----------

Choosing an On-Line Service	48
Looking for Goodies	53
Chatting on the Forums	54

Looking Ahead	54
----------------------	-----------

Chapter 4: The Traveling Mac	57
-------------------------------------	-----------

Built In: AppleTalk Remote Access	58
--	-----------

Making a Connection	58
Logging On	59
Using AppleTalk Remote Access	59

The Well-Connected Telecommuter	61
--	-----------

PowerBook Peripherals	61
Software for the Road	65
What to Carry, What to Leave Behind	69
Using the PowerBook as Your Desktop Mac	70
If Your Laptop Is Asleep	71
DOS for Mac Users	72
Choosing a DOS Laptop	73
Dealing with DOS	74
Looking Ahead	75
<hr/>	
Chapter 5: Network Plumbing	77
Built In: AppleTalk	78
Choosing a Data Link Mechanism	79
LocalTalk	80
Ethernet	81
When Packets Collide	82
Token Ring	83
ARCnet	85
FDDI	86
Choosing Media	86
Twisted-Pair	86
Coaxial Cabling	88
Fiber-Optic Cabling	89
Going Wireless	91
Setting Up a Local Area Network	95
Bus Topology	96
Star Topology	96
Backbone Topologies	101
Looking Ahead	103

Chapter 6: Connecting LANs: Internets	105
Built In: AppleTalk Phase 2	106
Using Internet Building Blocks	108
Bridges	109
Routers	109
Gateways	110
Planning an Internet	111
Network Traffic	112
Arranging Network Nodes	113
Creating Zones	117
Choosing a Router	119
Router Features	119
Routing on Your Mac	120
Routing on a PC	121
Half-Routers: Routing by Phone	122
Routing Non-AppleTalk Protocols	123
Installing a Router	124
Assigning Network Numbers	125
Upgrading to AppleTalk Phase 2	126
Looking Ahead	127

Chapter 7: Network Services	129
Built In: File and Print Services	130
Using Apple's Network Services	134
A Tale of Two Server Architectures	134
File-Sharing Setup	135
The AppleShare File Server	138
Using Third-Party Mac Services	144
An Alternative File Service	144

Print Services	146	
Electronic Mail	147	
Databases	150	
New Services	151	
Using the Mac as a Server Platform		153
Which Mac Server?	153	
Server Storage	155	
Outgrowing a Mac Server		156
Integrated PC-Based Network Operating Systems	157	
RISC and VAX Servers	159	
Looking Ahead		160
<hr/>		
Chapter 8: The UNIX Connection		163
Exploring UNIX, Mac-Style		165
Apple's A/UX	165	
An Alternative UNIX for Mac	168	
An Alternative Mac for UNIX	170	
Exploring the X Window System		171
Mac X	172	
eXodus	173	
Client X Window for Your Mac	174	
Running on TCP/IP Networks		175
Macs on TCP/IP	176	
Standard TCP/IP Services	177	
The TCP/IP Internet	178	
Using NFS File Servers as AFP Servers		179
Macs and NFS	180	
UNIX Hosts as AFP File Servers	181	
Mac-to-UNIX Gateway	182	
The Third Protocol	184	
Looking Ahead		185

Chapter 9: The VAX Connection	187
Built In: The Communications Toolbox	189
VAX and Mac Networking	190
The DECnet Network	192
AppleTalk for the VAX	193
VMS Application Access	194
Choosing a Terminal Emulator	194
DECwindows	199
The VAX as a Mac File and Print Server	200
PathWorks	200
Alisa and Pacer	203
VAX Electronic Mail Servers	203
PathWorks Mail Features	204
Third-Party Mail and Messaging	204
Looking Ahead	207

Chapter 10: Mainframe Connections	209
The Physical Connection	211
Coaxial Terminal Adapter Cards	212
Synchronous Data Link Control (SDLC)	214
Asynchronous Connections	214
Token Ring Network	215
Multi-Access Network Gateways	216
3270 Terminal Emulation Software	218
Apple's SNA•ps	219
Avatar's MacMainFrame Software	219
DCA's IRMA	220
Novell	221
Simware's SimMac	221

Front-Ending Host Software	221
Off-the-Shelf Front-End Solutions	222
Front-End Development	223
Client-Server Computing in the Mainframe Environment	225
Apple MacAPPC	226
Apple Data Access Language (DAL)	227
IBM LAN Resource Extension and Services/VM	227
IBM Backup Server	227
Accessing the Midrange	228
Looking Ahead	228
<hr/>	
Chapter 11: Database Connectivity	231
Built In: Database Hooks	232
Accessing Database Servers	234
Query Languages	234
Mac-Accessible Database Servers	237
Choosing Client Software	241
Office Productivity Applications	242
Specialized Query Applications	242
Data on the Map	244
Entering Enterprise Computing	244
The VITAL Model	246
VITAL Plans	250
Looking Ahead	251
<hr/>	
Chapter 12: Network Management and Troubleshooting Tools	253
Helping Users Over a Network	255

Backing Up over a Network	255
Providing Training and Tech Support	257
Using a Network to Manage Macs	258
Taking Inventory over a Network	259
Installing Software over a Network	263
Examining Rights: User's versus Network Manager's	265
Monitoring Networks	266
Monitoring Traffic	267
Monitoring Device Status	269
Monitoring with SNMP	271
Poking at Packets: Protocol Analyzers	274
Perusing Protocols	274
Perusing Packets	278
Poking Packets with Software	279
Poking Packets with Hardware	281
Looking Ahead	283
<hr/>	
Chapter 13: Networks across the Globe	285
Built In: The Apple Update-Based Routing Protocol	286
Adventures in WAN Routing	289
Basic WAN Routing	289
AURP Routing	291
A Look at AURP Routers	294
Connecting Tunnels	294
The Carrier Media	295
Switched 56	297
T1 Lines	298
Satellite Communications	298
ISDN: Networking in the Nineties	300
Dueling Protocols: OSI versus TCP/IP	304
X.25 Packet Switching	305

MacOSI Transport	307	
X.400 Mail	307	
Open Document Architecture	308	
Looking Ahead		309
<hr/>		
Chapter 14: Collaboration, the Next Step		311
Getting to the Core of OCE		313
Directory Services	313	
Mail/Messaging Services	315	
Authentication and Privacy Services	316	
Digital Signature Services	316	
Using OCE Directories		316
Directories in the Finder	316	
OCE and AppleTalk	318	
Using Mail and Messaging		319
The Mailbox	320	
The Mailer	320	
Messaging	322	
Employing Security		323
Authentication and Encryption	323	
Digital Signatures	324	
Looking Ahead to OCE Applications		325
Working with an OCE-Aware Database	326	
Telephones and Electronic Mail	327	
OCE in Workgroups and Workflow	328	
<hr/>		
Appendix Connectivity MiniFinder		329
Mac-to-PC		329
Telecommunications		332

Compression Utilities 332
Communications Software 332
Modems and Fax Modems 333
On-line Services 334

Portable Computing 335

Networks 336

ARCnet Interface Boards 336
Ethernet Boards, Hubs, and Routers 337
Token Ring 339
Network Services 340
Cutting Edge Networks 341
Wide-Area Networks 342

Mac-to-UNIX 344

Mac-to-VAX/VMS 345

Mac-to-Mainframe 347

Database Connectivity 349

Network Management Tools 352

Index 357

■ Foreword

Everyone knows about the Mac's graphical user interface. Point and click. Cut, copy, and paste. Drag and drop. These innovations are what made the Mac famous.

But the Macintosh contains another, perhaps more significant innovation: AppleTalk networking. Unlike DOS- and Windows-based PCs, on which network capability still is not standard, Macs have had a LocalTalk network port, and the Mac operating system has included AppleTalk networking protocols from the beginning. It is AppleTalk, and its integration into the Mac's graphical interface, that lets Mac users interconnect their machines, share laser printers and file servers, and exchange electronic mail messages as easily as they copy files between disks.

Perhaps that's why it has been almost a decade since the introduction of the Macintosh, and books on Mac connectivity such as the *MacUser Guide to Connectivity* by John Rizzo are only now beginning to appear. Connecting Macs is easy. So why write about it?

If Macs still were primarily used to connect only to other Macs, there might yet not be much reason to write a book about Macintosh connectivity. But Macs are no longer so isolated. They are no longer considered oddball machines. They can now be found on the approved-purchase lists of most major corporations. You can connect a half a dozen Macs and a PostScript laser printer and within a few hours, set up basic file and print services, using only the Mac's built-in networking capability, a few inexpensive connectors, and some phone wire. However, today's network administrator integrating Macs into rapidly changing, multiplatform corporate environments needs to know a bit more than how to daisy-chain together a few devices. Corporate America's need to connect Macs to each other by the hundreds—in some cases by the thousands—and to other computer systems and services already in place has caused the Mac connectivity picture to grow increasingly complex.

The scale of Macintosh networks is one factor behind this new complexity. Although small workgroups of Mac users sharing a printer and an AppleShare file server may have been the norm even as recently as a couple of years ago, today many Mac sites are combining hundreds of Mac users in dozens of departmental workgroup networks into unified internets (networks of networks) that span a corporate campus—or an entire international enterprise.

Users' need for increased network bandwidth—speed—is another factor chipping away at the simplicity of the good old days. As users' desires to move digitized 24-bit color images, sound, and video across their networks become more commonplace, the Mac's built-in LocalTalk network capability is being stretched to the breaking point. Macs are being moved to higher-bandwidth Ethernet networks so rapidly that Ethernet interface cards for Macintosh

computers, once a high-priced item, almost overnight, have become a commodity. Apple has even begun building an Ethernet interface directly into the motherboards of its Quadra models.

These changes require that system administrators learn and understand a whole new set of networking hardware and software tools. And perhaps most importantly, managers at many corporate sites have begun to see the value of the Macintosh as a universal client. Macs are sharing data with PCs on Novell NetWare, Banyan VINES, and Microsoft Lan Manager networks. Macs are being outfitted with token ring, SDLC, or coax interface cards, and integrated into IBM SNA networks. Macs are being used on DECnet networks as intelligent front ends for applications running on Digital's VAX minicomputers. Macs are communicating with Sun, Silicon Graphics, and other UNIX workstations via TCP/IP protocols over corporate Ethernet networks. Through gateways, users are exchanging electronic mail with users of cc:Mail, All-in-One, MHS, PROFS, and many other e-mail systems, which run on a variety of different computers. Macs are logging onto a growing list of data base servers—including Oracle, Sybase, Ingress—and using Apple's DAL (Data Access Language) to download data directly into spreadsheets, data analyses, and charting programs.

Yet because of the Mac's very success as the most personal of personal computers, it still is thought of by many as a standalone computing device, with only limited options for being an equal—let alone superior—member of a complex networking and communication system. John Rizzo's *MacUser Guide to Connectivity* is a valuable resource for those who know better. Here, in one volume, John has assembled a broad survey of connectivity and networking solutions for Macintosh computer users. From the simplest telecommunications tasks to the most complex challenges of internetworking and cross-platform integration, you will find here the information you need to point you toward a solution to your connectivity and networking problems. As a bonus, John has included a chapter on Apple's forthcoming Open Collaboration Environment, an extension to System 7 due early in 1993 that promises to redefine the way people use computers to communicate information. This is a book that everyone interested in Macintosh connectivity—particularly network administrators—will want in his or her collection.

—Henry Bortman
Technical Director, *MacUser*

■ Acknowledgments

I am indebted to many people who helped me during the two years or so it took this book to come together. Much of the success of this project must be attributed to the efforts of Melinda Levine, one of the best editors with whom I have had the privilege to work. Also thanks to copyeditor Sandy Horwich for filling in the gaps—at times I could swear she was reading my mind. Working with them both was a uniquely enjoyable experience. Also thanks to Henry Bortman for helping me flush out the dogma. His thought-provoking arguments made me rethink even my most solidly held positions. And thanks to the management at *MacUser* for the use of the lab facilities and for allowing me to keep rather unorthodox hours.

Also instrumental were the many developers who gave me their time and expertise. This list is very long indeed, but I do want to mention just a few of my teachers: Cimeron Boozer of Sytron (formerly of Cayman Systems), who submitted to many long discussions on TCP/IP and UNIX, Elizabeth McGee of Shiva, Brad Farkus of Argosy, Trudy Edelson of Farallon, and Dennis Hayes. Thanks to the folks at Pacer, Alisa, Orange Micro, White Pine, Intercon, as well to many others. Special thanks go to all the people at Apple Computer whom I bothered for weeks on end, including Miles Morimoto, Gursharan Sidhu, Subhash Chowdary, Jeff Benrey, Nancy Morrison, Patricia Chan, Cindy McCaffrey, and many more.

Finally, I'd like to express my gratitude to Maggie Cannon for starting me on this path.

■ Introduction

You don't have to be a brain surgeon to know how to wear a hat. Similarly, you don't need a degree in computer science to use a Mac. This philosophy also applies to Macintosh connectivity, whether you're reading DOS files or setting up networks. That's also the philosophy of this book. That's why you won't see at the beginning of this book a detailed discussion of how the datagram delivery protocol interacts with the AppleTalk transport protocol. AppleTalk was designed so that the user and network designer wouldn't have to know how protocols work.

This is a solutions-oriented book, designed to be your consultant. This book tells you what you need to know to plan for, shop for, and set up connectivity systems. You'll find practical, useful information, whether you're a single user looking for connectivity solutions for your own individual use, or in charge of a Mac workgroup and looking to setup or expand a network or connect your Macs to other computers. You could even be a network manager interested in the scope of management tools available or an expert in PC or mainframe connectivity interested in integrating Macs to your environment. The solutions you seek may range from simple software applications that cost under \$100 to complex nation-wide networks of mixed computers. You'll find a discussion of the seven-layer AppleTalk protocol stack only when you need it, as part of the discussions of network troubleshooting in Chapter 12.

Most of the chapters begin with a section entitled "Built In," which explains the connectivity features that come free with your Mac and explores their strengths as well as their weaknesses. These sections will help you to decide when you can make do with what Apple provides and when you need to purchase additional connectivity tools.

Throughout the book, I've provided examples of the alternative solutions available for each connectivity method and have described products available for the task. Since computer software and hardware is in a constant state of evolution, I've pointed out the major features to look for and listed some of the products that do a good job of implementing these features. Many of the recommendations come from the results of testing in MacUser labs. A directory in the Appendix lists the major vendors in all the areas of Mac connectivity.

■ How to Use This Book

The book progresses from describing the simplest connectivity methods to the more complex solutions. The book can be read straight through or used as a reference guide. The book is also arranged in the way most people learn about connectivity, so you can start reading where your knowledge ends and stop

where your requirements end. For instance, a reader in a small business new to connectivity might start at Chapter 1 and stop at Chapter 7 (at least until the business grows to require more complex connectivity solutions). A reader interested in setting up a big network from scratch might start at Chapter 6 and continue to Chapter 14. Later chapters assume you know the material mentioned earlier. However, there are frequent references to topics discussed in previous chapters if you need to jump into the middle of a discussion.

The chapters are grouped together in clusters of related topics. Chapter 1 contains introductory material on just what is meant by Macintosh connectivity. Chapters 2 through 4 examine, for the most part, non-network issues of connectivity, though there are some introductions to techniques that illustrate what is offered by a move to a network. Networks are explained in more detail in Chapters 5, 6, and 7, which cover the design of networks, from small to large. Since Macs don't exist in a world by themselves, connections with other types of computers are discussed in these and most other chapters in the book.

Chapter 8, 9, and 10 discuss how to create Macintosh links with the three major host environments: UNIX, VAX VMS, and IBM mainframes. These discussions are followed in Chapter 11 by a look at database connectivity, one of the major reasons for connecting a Mac to a big host computer.

Chapter 12 discusses the options available for managing networks and using networks to manage Macs. The topic of Chapter 13 is the expansion of networks across long distances.

Everyone should read Chapter 14, a look at a developing technology—Apple's Open Collaboration Environment—that will be added to System 7 during the next few years. This technology is often misunderstood, but it has the potential to reshape and redefine Macintosh connectivity.

- *No Mac Is an Island*
 - *Free Connectivity*
 - *Connectivity for the Rest of Us*
 - *The Multi-Operating System Mac*
-

C H A P T E R

1

Built-in Connectivity



THE MACINTOSH IS A GREAT CONNECTIVITY MACHINE. BRING some Macs into an office and bridges will start to be formed over the desktops. The Mac is both a platform for information exchange and a creator of connectivity. When using your Mac for data exchange, you come to appreciate the same power, elegance, and ease of use associated with data processing on the Mac.

The Mac didn't start out in 1984 as a great connectivity machine. Connectivity has been added a bit at a time, as the Mac evolved from a nonexpandable, closed box to today's line of more than a dozen different models. The difference between Apple and other PC manufacturers has been in its approach to connectivity: Instead of providing add-in cards and software designed to be set up and run by experts, Apple has built connectivity into the core hardware, software, and interface. This has made connectivity Mac-like.

Connectivity began with Apple's desire to create an easy method of hooking Macs together to share printers. Apple came up with the Apple Print Sharing Bus, which soon became the basis for a complete network architecture: AppleTalk. Apple also built connectivity into its revolutionary new printer, the LaserWriter. For the first time ever, sharing a printer was as simple a matter as stringing together \$50 connectors with telephone wire. This linking worked so well that together with font technology and the mouse, it helped spawn an entire industry—desktop publishing. The success of desktop publishing was a welcome surprise to Apple and possibly saved the Mac from early extinction. Realizing they were on to something, the developers at Apple continued to expand the Mac's connective capabilities. The Apple File Protocol (AFP) and AppleShare added file transfer between Macs. Groups of individual and networked Macs started popping up all over the place, to the astonishment of corporate MIS (management information systems) departments. Today, over two-thirds of all Macs are connected to a network, but only one-third of PCs are networked.

Enabling Macs to communicate with each other was all well and good, but in a world where the Mac was a minority player, Apple realized that it had to make the Mac fit in with other computers and other types of networks as well. So Apple began building in ways that would make use of industry connectivity standards while convincing the major network vendors—Novell, Digital, Microsoft, and others—to use AFP in their Mac products. As a result, the Mac user can now communicate with them all: from laptops to mainframes. Lack of compatibility is no longer a reason to exclude Macs from your company.

Connectivity is more than networks, and networks are more than passing files over wires. Connectivity is reading a WordStar file on your Mac, or searching for library documents through a modem, or sending a copy of an electronic mail message to hundreds of different computer users. The goal of connectivity is to get information in and out of your machine, regardless of where it came from, where it's going, or what form it's in.

Of course, we have yet to completely realize this goal. Users still require some knowledge of the workings of connectivity, and a great deal more is required of the people who set up and run complex networks. But we are

moving toward the day when the computer user will no more require knowledge of protocols than a car driver, knowledge of how the engine works. We're even beginning to enter the time when not only data, but processing power itself, will be shared among connected computers.

For today, the message for managers of large numbers of computers is that the Mac can be integrated into your environment. The message for the user is you don't have to become a network manager to take advantage of the powerful connectivity capabilities your Mac has to offer.

■ No Mac Is an Island

Few Macs are islands of computing. For one, there's not much you can do all by yourself. The process of writing this book, for instance, involved converting electronic words to paper and back, and passing text and illustrations between various computers in different formats. The fact is, Macs exist in a world of other Macs, peripherals, PCs, and higher-end computers with five-digit numbers for names.

Some may consider the existence of other computers a necessary evil, but the diversity of a mixed computing environment is really an opportunity. Connectivity offers access to information and services found beyond the boundaries of your desktop. Connectivity is a form of electronic synergy, offering an organization more power than is found in the sum of the individual machines. Connectivity enables you to automate tasks you have been doing by hand, and to participate in a bigger group effort. Connectivity lets you keep a Macintosh on your desk in an office dominated by non-Mac computing standards.

■ Free Connectivity

The offer of free anything usually gets people's attention, but many users are unaware of the free connectivity tools that come with every Mac. These are not ginsu knives we're talking about, but a set of integrated hardware and software features that you'll use every day. Most of the chapters in this book begin by describing these free built-in connectivity tools. Some of them come in the form of tangible end-user items for which you'd have to pay extra with other computers, such as hardware ports (see Figure 1.1) and networking software. Consider these PC options that are standard on the Mac: graphical user interface; floppy drive that reads foreign file formats; serial port; WAN (wide area network) software in laptops; network port; SCSI controller card; file sharing software; print spooler. The total of these products could almost buy another PC.

Figure 1.1

Apple's free connectivity includes the ports on the back of every Mac.

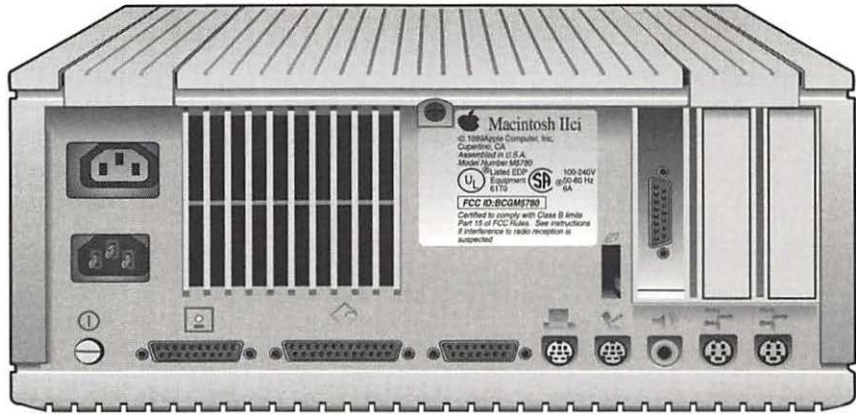

Other standard Mac features don't have a price tag, but are just as important. These features are hidden in the Mac's operating system and ROM, revealing themselves in the ease of use of Mac connectivity or in the third-party add-on products that are built on top of them. Plug in a card and an extension file and you've got Ethernet; click on a Chooser icon and you've logged onto a UNIX file server; choose a name in a dialog box and you've just imported mainframe data into your Mac application. You can make the most of your Macintosh dollar by getting to know these features.

■ Connectivity for the Rest of Us

Even if the PC vendors gave you a box filled with the connectivity hardware and software that comes with a Mac, the Mac user would be ahead of the game: The Mac's built-in connectivity is designed to make connectivity natural. The Mac brings connectivity down from the level of the gurus to the level of the rest of us. Many users take the Mac's built-in connectivity tools for granted, sometimes not even realizing they are using connectivity tools. This is not to say that there is not a need for the experts; the Mac can be involved in some very complicated networking schemes, as you will see in later chapters. But people who claim to know nothing about connectivity use it every day.

Consider the number of steps it would take you to connect a brand new Mac to a text file over a network. You'd remove the Mac from its box, install the appropriate software, plug it into a network, log onto a file server, and open a text file on the server. If you count procedures like "Click OK" as

one step, the number of steps is somewhere around 20. Now do the same for a PC. Depending on the model, the same process would take about 130 steps.

Another example of the Mac's natural connectivity is the Chooser desk accessory, shown in Figure 1.2, which was originally designed as an easy way to select a printer from among dozens available on a network. The Chooser uses a single laser printer driver for most laser printers on a network. (A few printer vendors offer a special feature through their own printer drivers.) You don't have to know the brand of the printer, you just pick a name from the list. (See Figure 1.2.) This is far different than in the PC world, where installation of multiple device drivers is the norm. These days, the Chooser provides the same easy connection method for all kinds of services; so you select a file server the same way you select a printer.

This is not to say that connectivity ease of use has gone as far as it can. There are still gaps in the Macintosh operating system and product line that must be filled with third-party products. Overall, connectivity is still too hard, not so much for the user, but for the people who set up the connections and infrastructures in big networks. Too much knowledge is still required. A big problem is that the complexity of connectivity is increasing even more quickly than the number of new computers, operating systems, and types of networks. Still, Mac users have more blessings to count than users of less connectivity-endowed machines.

Figure 1.2

The Chooser typifies the ease of use of the Mac's built-in connectivity, supplying a single interface to select different network services.

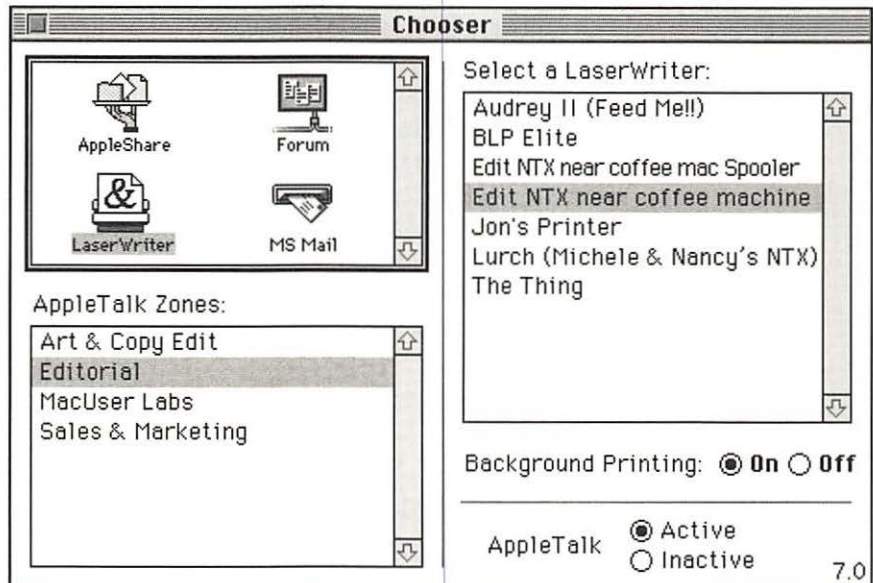

■ The Many Operating Systems of Mac

Since the first 128k Macintosh, a common reason to keep Macs out of an organization has been the absence of a Mac version of some critical software that runs on another platform. Fortunately, this excuse is becoming rarer all the time, since you're more likely than ever to find some way to run the software you need.

Many PC and UNIX applications now offer Mac versions. Mac software is migrating over to the other platforms as well. Lotus 1-2-3 now runs on the Mac, and Excel runs on Microsoft Windows. PC and Mac versions of an application can usually read each other's files. File translator utilities are available to convert files between applications that can't.

If these alternatives aren't available, as is the case with more vertically oriented applications such as software written specifically for your company, don't give up hope, because you aren't limited to running Mac software or the standard Mac operating system. Through products from Apple and others, you can run or emulate a variety of operating systems. There are several different ways to run DOS on a Mac, and you can even run Microsoft Windows if you are so inclined. You also can install UNIX, as well as the Apple II's Pro-DOS. All of these require extra hardware or software.

You can't shrink mainframe applications to fit on a desktop computer, but there are terminal emulators and front-ends to mainframe software that run on the Mac. And Mac programs and query languages exist that make connections to mainframe databases and query languages. If there isn't a Mac software interface available, you can write one of your own using one of the various APIs (application program interfaces). Any of these solutions can make the distance between a Mac user and the volumes of data stored on mainframes a mouse click away.

Regardless of what operating system, software, or interface you run on your Mac, you can share information with other computers. You can do it and you should do it. How you'll do it depends on your needs, your knowledge, and your budget. We'll start in Chapter 2 by looking at ways of building bridges to PCs running DOS, OS/2, and Windows, which still account for over 80 percent of all desktop computers.

- *Built In: Reading DOS Disks*
 - *Non-Network Connections to PCs*
 - *Translating Files between a Mac and a PC*
 - *Running DOS on Your Mac*
 - *Mixing Macs and PCs on a Network*
 - *Printing to PC Printers*
-

C H A P T E R

2

Sharing Files with PCs



THE WALL BETWEEN MACS AND PCS THAT MANY USERS OF both machines still perceive has already been torn down. Apple long ago abandoned its isolationist view of the personal computer, and the “evil empire” of Big Blue has come to terms with the Mac, recognizing it as a positive force in the office environment. Everyone is profiting, particularly users who have made the passing of information between Macs and PCs a commonplace activity.

Your Mac can read and write files in formats understood by PCs running DOS, OS/2, and Microsoft Windows. With an extra file in your System Folder, you can treat a PC disk as a Mac disk. It doesn't matter what type of PC you're using, since differences in PC hardware do not usually affect the Mac's data exchange capabilities.

The methods for sharing files with PCs run the gamut from cheap and simple to expensive and complex. Although you usually get what you pay for, you don't want to pay for what you don't need. More expensive methods give you the advantages of increased speed and quantity of computers involved. The simplest way of sharing files is to read and write PC-compatible floppy disks or removable cartridges directly on your Mac. From there you can move up to a direct serial or modem connection to a PC, or connect Macs and PCs together on the same network. After transferring the files, you may have to use translation software to convert the files into a format your Mac applications can understand. But if no Mac application is appropriate for your purposes, you can run the PC application itself on your Mac by actually running the DOS or OS/2 operating system on your Mac. Finally, when you're finished with your file, you can output it on printers made for the PC.

The sharing of files between Macs and PCs has become increasingly Mac-like, but there are some things about the PC to keep in mind. Files on PCs aren't kept in folders, but are organized into directories. Directories will appear as folders when a PC disk is read on a Mac. You'll also need to pay attention to what you call your files. Although Mac folder and file names can be 32 characters long, PC directory and file names are limited to 8 characters plus a 3-character extension after a period. Mac file names moving to the PC will be truncated. In addition, certain characters that are used in Mac file names are forbidden in DOS file names. Spaces, asterisks, and slashes aren't allowed.

Built In: Reading DOS Disks

Since 1989, all Mac models (except the Mac Plus) have shipped with the SuperDrive, an internal 3.5-inch floppy drive with the ability to read and write foreign-format floppies. (You may also know the drive by its earlier name, *FDHD*—pronounced *fud-hud*—short for “floppy-drive, high density.” Apple dropped the name in favor of its current, more Mac-like name, SuperDrive, some time ago.) The older Mac 800k floppy drive could only read, write, and format Mac 400k and 800k disks; the SuperDrive added similar capabilities for Apple II ProDOS, OS/2, and MS-DOS floppies in 720k and 1.44Mb formats, as well as 1.44Mb Mac floppies.

The only models that don't have a SuperDrive are the original 128k Mac, the 512, and the Plus. Older Mac SEs also don't have a SuperDrive, because it was added in the middle of the SE's production life. Some, but not all, of

the SEs that do have SuperDrives are marked with *FDHD* on the front, but the way to tell for sure is to insert a Mac-formatted 1.44Mb floppy in the drive. If the Mac asks you if you want to format the disk, the drive is not a SuperDrive. For those of you with an older SE, Apple has an upgrade kit.

Apple's external SuperDrives won't work on Macs that don't have internal SuperDrives, because these computers are missing crucial SuperDrive circuitry called "SWIM." However, you can buy similar external drives from third-party vendors, which will work with pre-SWIM Macs. You can also buy external drives from Apple and other vendors that will read 5.25-inch DOS floppies on most Mac models. The DaynaFile is the most popular 5.25-inch floppy drive for Macintosh. It should also be noted that there are several solutions for PCs that allow PC drives to read Mac floppies or for Mac floppy drives to be connected to PCs.

Although the drive hardware does a good job of allowing the Mac to read foreign disks, the Finder lags behind, so a stock Mac won't let you mount a DOS or OS/2 disk on the desktop, the way it mounts Mac floppies. Apple's solution has been a utility that comes free on the system disks called Apple File Exchange. It works, but there are better solutions listed below.

■ Non-Network Connections to PCs

Networks have many advantages, but are not always the right solution for Mac-to-PC connectivity. The increased speed and number of computers connected may not warrant the extra cost and maintenance requirements of a network. In fact, you may not have to have a physical connection between the Macs and PCs at all. You might need to share information with a PC in another location, or read a disk from an anonymous PC. Your Mac might be at home, or it might be the lone Mac in an office full of PCs. In any of these cases, you don't need a lot of money or technical expertise to open a dialog with a PC.

Sharing Disks

Apple File Exchange, Apple's free solution for reading DOS disks is not particularly intuitive or Mac-like. Even though the SuperDrive can read and write to a DOS-formatted disk, the Finder will ask you if you want to format a DOS disk when you insert one into a Mac. To bypass the ignorant Finder, open Apple File Exchange before inserting the DOS disk.

Fortunately, you can avoid all this unpleasantness by using one of several inexpensive products that enable the Finder to recognize PC disks. By dropping a small file into your System Folder, a DOS disk—like a Mac disk—will

mount on your Mac desktop whenever you insert it (see Figure 2.1). The disk will behave exactly like a Mac disk, and you can click and drag files to copy files between Mac and PC disks.

Figure 2.1

Mounting a DOS disk on your Mac desktop with DOS Mounter

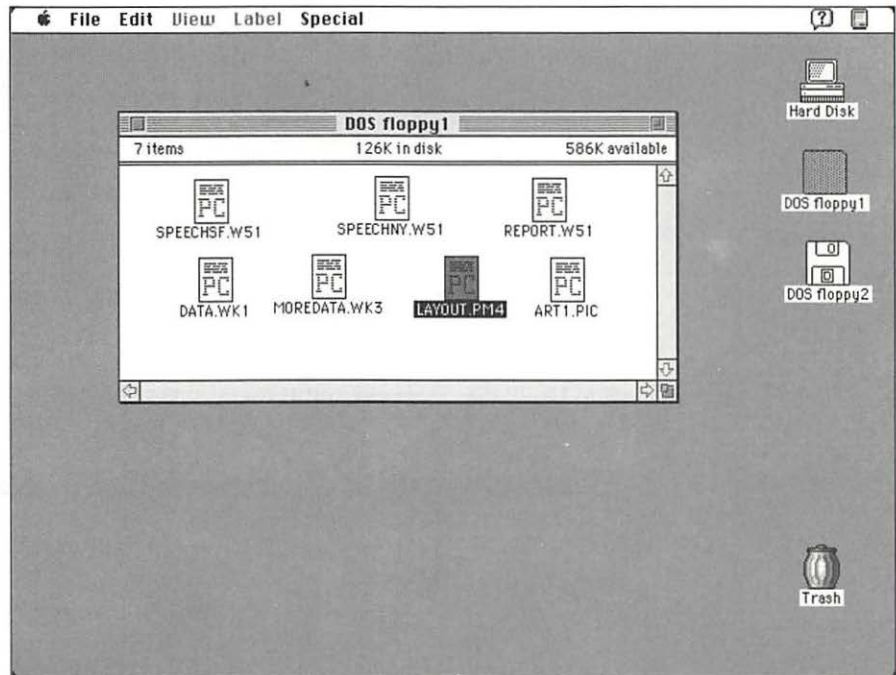

These utilities will assign an icon to DOS files, which differentiates them from Mac files. With version 3.0 or later of Dayna's DOS Mounter, the first DOS disk-mounting utility, a unique DOS-specific icon is also assigned to the PC disks. Most of the DOS disk-mounting utilities are very similar and cost under \$100. You can also find these utilities bundled with other products, such as file-translation programs. Apple sells one, called Macintosh PC Exchange, which covers the basics, but it is not as full-featured as DOS Mounter or Insignia's AccessPC.

The DOS disk-mounting utilities also perform a function called *extension mapping*, which takes effect when you copy DOS files to Mac disks. This allows you to double-click a DOS file and have it open in a Mac application. (If the application can't read the file format, you'll have to use a file translator, described later in this chapter under "Translation Software.") Extension mapping looks at the three-character extension at the end of a DOS file name and assigns a four-letter Mac "Creator" and "Type" to the

file. The Creator code (*XCEL* for Excel, for example) designates the application that will open when you double-click on the file. For instance, you can assign all DOS files ending in *.DOC* to open in Microsoft Word, which uses the creator *MSWD* (see Figure 2.2).

Figure 2.2

Extension mapping enables a DOS file to be opened with a Mac application when the file icon is double-clicked.

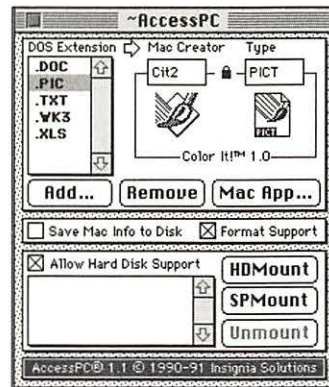

The Type code designates the format of the file. This can be a generic format standard, such as Text, PICT, or WKS, or an application-specific format such as WDBN for Word 4.0. Files that are applications have the Type code APPL. Type and Creator codes are invisible, so you'll need to use the Get Info command of Apple's ResEdit utility or CE Software's Disktop if you want to change the Creator or Type after you copy the file to the Mac. (ResEdit is a free utility used to change aspects of a file that are usually unalterable.)

When copying Mac files to a DOS disk, the DOS disk-mounting utilities store both a Mac and a DOS file name on the disk. For example, "Rizzo Recipes" on the Mac becomes "RIZZORE&" on the DOS disk. The ampersand lets you know that the name has been truncated. A second file with a similar name, *Rizzo Recipes/Italian*, becomes *RIZZORE1*. A third file with the same first seven characters would become *RIZZORE2*. DOS Mounter always shows you the Mac name when the disk is mounted on the Mac, and the DOS name when the disk is viewed from a PC. AccessPC, another DOS disk-mounting utility, always displays the DOS name, even if the DOS disk is in a Mac.

The DOS disk-mounting utilities also work with larger-capacity removable storage media, such as Syquest, Bernoulli, and erasable optical cartridges. If your removable cartridge has DOS partitions, the DOS disk-mounting utilities can mount each of them as a separate desktop volume.

There is a problem with some of the DOS software drivers on cartridges: Those drivers that don't follow Apple's specifications (and there's no reason why they should) won't mount on the desktop. These drivers don't tell the Finder that a disk has been inserted when a non-Mac disk is in the drive.

DOS Mounter and AccessPC get around this by supplying a universal driver formatter. With this tool, you can update the driver on the Syquest cartridge, which will keep your data intact, or reformat the Syquest, which will erase all data on the cartridge.

Serial Connections

A serial connection between a Mac and PC is about one-quarter of the speed of a LocalTalk network, but is inexpensive and fairly simple to set up. A serial connection can be made with a cable directly connected between the two machines or with a modem over telephone lines. A direct serial connection is faster, running at speeds of up to 57,600 bits per second (bps), but some software and PC serial ports can only run at a maximum of 19,200 bps. You can buy a serial cable at a computer dealer for connecting a Mac's Mini DIN-8 modem port to a PC's 9-pin or 25-pin COM1 or COM2 port. Some cables come with both PC connectors on one end.

With either modem or cable connection, there are two classes of file transfer software that you can use. The easier of the two to set up is the class of file translation packages that comes with file-transfer capabilities, such as MacLinkPlus/PC from DataViz and RunPC/Remote from Argosy, or LapLink/Mac from Traveling Software. (The file translation features of these types of programs are described in the next section.) These packages come in several versions, but for Mac/PC file transfer, you'll need the complete versions, which come with software for both computers and a serial cable.

You can also do a serial file transfer with telecom software using either modems or a serial cable. Zterm will work just fine in either case. Quality commercial packages include Microphone SmartCom, and White Knight. On the PC, choose a telecom program that supports the Xmodem or Ymodem protocol.

If you're using a modem, another option is to use an intermediary on-line service such as CompuServe or America On-line (described in Chapter 3) to transfer files. The benefit here is that the sender and recipient don't have to be on line at the same time—the service will store the message or file until the recipient asks for it.

■ Translating Files between a Mac and a PC

Moving files between a Mac and a PC is only the first step, because Mac and PC files are often written in different file formats. If this is the case, the format will have to be translated into one your application can read. You have several translation options. You can use intermediate formats that applications on the Mac and PC can understand. Sometimes the Mac and PC applications can do the translation between Mac and PC formats themselves. When the applications don't speak the same language, you'll need stand-alone translation software (sometimes called *filters*) to convert files from the foreign format to one your computer application can read.

Applications That Translate

Today, there is a great deal of capability built into business applications to translate files between the Mac and DOS versions of their programs. For example, Microsoft Word for Windows will read unaltered text files from the Mac version of Word, and WordPerfect for Mac will read files created with WordPerfect for Windows.

For translating between different applications, you might need to save a file in a particular format before you export it to the other computer. For instance, if you want your Mac Excel files to be read by Lotus 1-2-3 on a PC, you'd save them in WKS, WK1, or WK3 format, depending on the version of 1-2-3. You can also save spreadsheet files as text, but you will lose your formulas in the process. Of course, the number and type of file formats available in a program depend on the software manufacturer. Lotus 1-2-3 for Macintosh, for example, contains a very comprehensive set of formats and can directly read and write Excel files in their native format.

Fonts sometimes have difficulty making the trip from Mac to PC, particularly the so-called upper ASCII characters, such as bullets [•], em dashes [—], and apostrophes. This is because the Macintosh operating system defines all 256 ASCII characters, while DOS defines 128 characters, leaving the rest to be defined by the individual DOS applications, which don't always use the same coding. Saving a file in Microsoft's RTF (Rich Text Format) can sometimes help a program like PageMaker, which can translate some of the upper ASCII characters from RTF. Unfortunately, even Microsoft implements RTF differently in different versions of its software, so results can vary.

Graphics files tend to be the most troublesome to translate, but there are a few intermediary formats that both Mac and PC programs can use. Many Mac and PC graphics programs worth their salt can output EPS (encapsulated postscript), which can be input into many nongraphic Mac and PC programs, such as PageMaker. However, not all EPS is alike. If you need an editable file, you may run into trouble. Adobe Illustrator 88 EPS

format is a good format to use for editable EPS, since several Mac programs support it directly.

Most Mac and PC graphics programs can also save in bit-mapped TIFF format. Mac TIFF and PC TIFF also differ from each other, but there are fewer problems than with EPS. Adobe PhotoShop can save directly in PC TIFF format. PhotoShop can also import and export in PCX, GIF, and TGA, three PC bit-mapped formats that are not common on Mac programs.

However, the Mac applications that have gone the farthest towards building in actual file translation are those that have incorporated XTND (pronounced *extend*) technology, originally developed by Claris but now distributed by Apple. XTND enables users to add file formats to XTND-compatible programs by simply dropping a translator file into a folder. The file formats then show up in a menu inside the application's Open, Save, or Save As menu, as shown in Figure 2.3. If the application doesn't ship with the file format you require, often you can buy additional file translators.

Figure 2.3

XTND-compatible applications enable the user to add file formats to menus within the application.

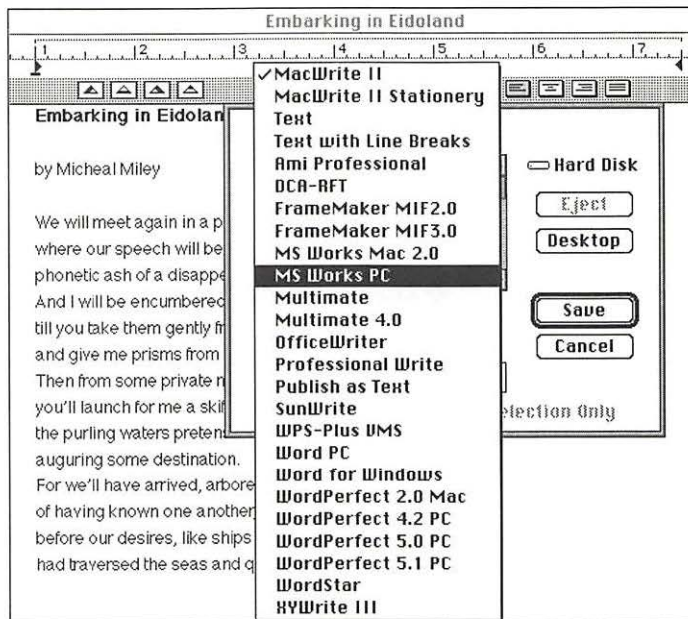

A few of the applications that make use of XTND are much of Claris's product line (such as MacWrite II, FileMaker Pro, and Claris CAD), WordPerfect, Ragtime3, and GreatWorks from Symantec.

Translation Software

The first third-party file translator to work with Claris's XTND technology was DataViz's MacLinkPlus, which was already a well-established stand-alone translator package. Since many applications don't use XTND, you may need such a stand-alone package. You know you need a translator if, instead of the columns, margins, bold, and italics you spent so much time creating on the PC, you get random gibberish when you open the file with a Mac application. The gibberish comes from the code that specifies your formatting on the PC. The Mac application will not always understand this code, and will substitute random characters. The same is true when going from Mac to PC. A file translator goes the extra step to translate the formatting code between the Mac and PC applications and between different Mac applications.

File translation packages often come in different versions—one that includes a serial cable for connecting a Mac and PC directly and one that assumes you'll transfer your files with floppies, via modem, or over a network. The traditional translation application looks like the one in Figure 2.4. You choose the file you need to translate, choose the before and after file formats, and click on a button. However, using a combination of extension mapping and System 7's IAC capabilities, translator packages such as Argosy's Software Bridge or DataViz's MacLinkPlus, 6.0 or later, enable you to set up transparent translation: Double-click on a XYWrite file and it automatically translates and opens in Nisus format. You can also translate a file by dragging it over the application icon.

Figure 2.4

After selecting the file you want to translate, MacLinkPlus asks you to pick the file format you need.

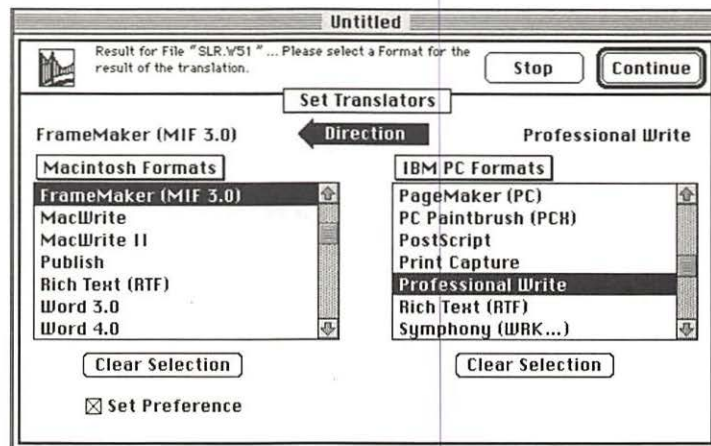

Some of these file translation packages offer a broad range of application formats in word processing, spreadsheets, databases, and graphics; and others focus on a single category. MacLinkPlus has the broadest range of file types, and can translate between some graphics files, such as the Mac and PC versions of TIFF. The packages vary in the quality of the translation, which is measured by the amount of formatting detail retained during the translation. Also, the best packages can initiate a translation from both the Mac and PC. Watch out for packages that work only from the PC since these are not very convenient for Mac users.

■ Running DOS on Your Mac

Sometimes reading a DOS file on your Mac isn't good enough—you have to run the PC program the file was created with, for which there is no Mac equivalent. Fortunately, you can have your Mac and PC, too, by running DOS and PC applications on your Mac. If this seems a waste of a good interface, don't worry, the command line won't take over your Mac. You still get the familiar Finder and Mac applications, with DOS (and even Microsoft Windows) confined to a Mac-like window.

There are three methods for running DOS on your Mac: using software, hardware, and a network. The software solution emulates DOS using the standard Mac hardware. This is the slowest but cheapest method. The hardware approach puts an actual PC in your NuBus slot. This is the most expensive solution, but is by far the fastest and is highly PC compatible, because it uses the same chips as a real PC. The third and most PC-compatible method is to run DOS or OS/2 on an actual PC, but to control it from a Mac over a network.

DOS via Software and Hardware

Except for speed and cost, the software and hardware solutions for running DOS on a Mac work in similar ways. When activated, DOS “boots” in a Mac window with the familiar DOS cursor. PC applications are installed using normal DOS methods. The “A” drive, usually a PC's internal floppy drive, can be your Mac's 3.5-inch floppy drive if it's a SuperDrive (discussed at the beginning of this chapter). The “C” drive, which is usually the boot drive on a PC, is simulated by a special file on the Mac's hard disk. Your DOS window can see other hard disk and floppy disk drives attached to your Mac, including a 5.25-inch floppy.

SoftPC from Insignia is the only software application that emulates DOS on your Mac, but has been around for several years and is represented by a mature line of products (see Figure 2.5). A good companion product is

AccessPC, Insignia's DOS drive-mounting utility, which enables you to mount your C drive file on your Mac desktop, giving you double-click viewing and click-and-drag copying of files. SoftPC will also let you read DOS CD-ROM disks in your Mac CD-ROM drive. SoftPC emulates CGA and EGA video in the DOS window, and emulates the COM1 and COM2 serial ports of a PC/AT. This lets you use your Mac's modem and printer ports to connect PC applications to modems, printers, and plotters. SoftPC also emulates a PC/AT parallel printer port (LPT1), allowing a PC application to print to a Macintosh printer connected to the Mac's serial printer port.

Figure 2.5

SoftPC from Insignia emulates the DOS operating system on your Mac to let you run DOS or Windows applications.

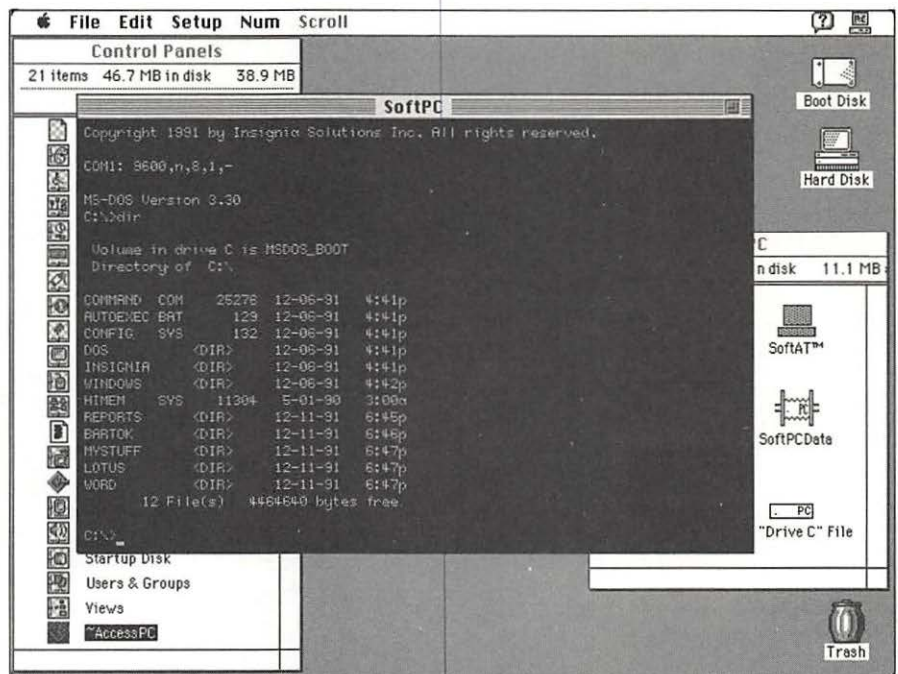

SoftPC emulates an 80286-based PC, but is slower than an actual 286 because the emulation is all done in software. For a beefier PC on your Mac, you can install one of Orange Micro's Orange386 boards, which offer over ten times the speed. The board is powered by an actual 80386sx processor, so you get the performance of a 386-based PC. It costs as much as a PC, but having it in your Mac adds functionality that a stand-alone PC doesn't have, such as a cut-and-paste capability between Mac and DOS or OS/2 applications. In addition, the board has two slots for standard AT-bus add-in cards

(as shown in Figure 2.6) that obscure one or two additional NuBus slots, depending on the card and Mac model. By filling one of the Orange386's AT slots with a PC network card, you can connect your Mac to any PC network.

Figure 2.6

The Orange386 card puts a complete 80386sx PC in your Mac, complete with AT-bus slots.

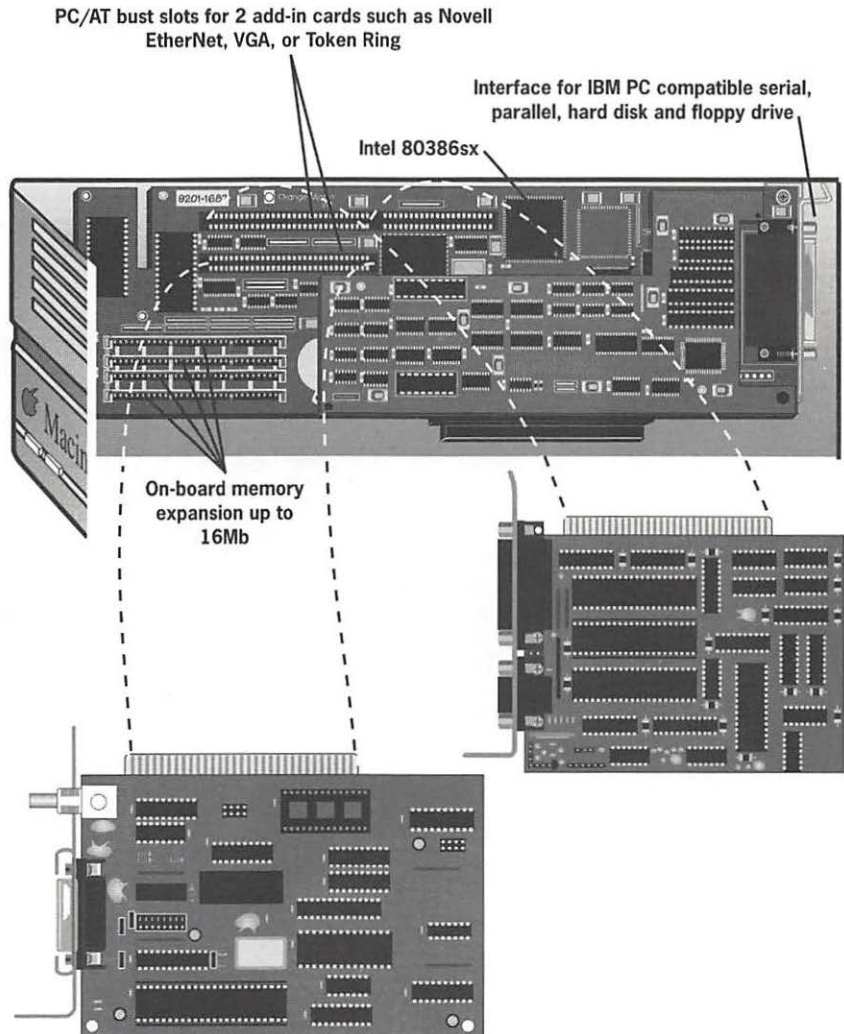

Like SoftPC, the Orange386 gives you DOS in a window, but also lets you run OS/2 in a window. You can also run VGA video with an optional VGA card and a multisync monitor. You can put up to 16Mb of RAM on the coprocessor card, completely freeing your Mac hardware for other tasks. In

addition to being able to access Mac peripherals, the Orange386 will also connect to PC peripherals through the board's serial, parallel, hard disk, and floppy ports.

DOS via a Network

The third method of putting DOS or OS/2 in a Mac window lets you control a PC from your Mac over an AppleTalk network, but the effect is still the same as having DOS on your Mac (see Figure 2.7). The PC you choose to control can be used as a workstation, but it makes more sense to dedicate it as sort of a PC server, available to any Mac on the network.

Figure 2.7

RunPC lets you control a PC from your Mac.

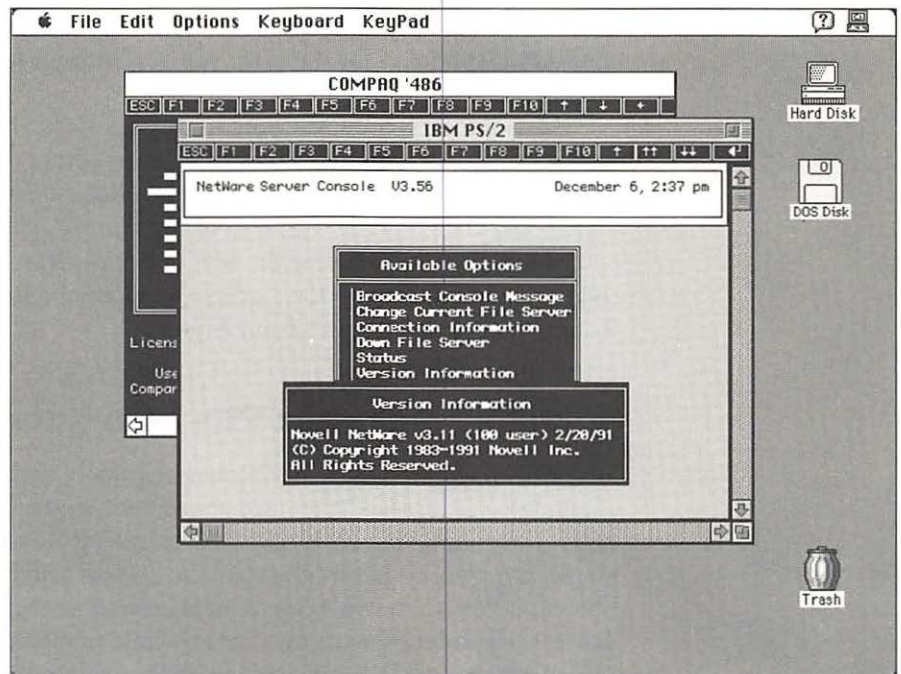

Like the Orange386, all the processing is done on the PC hardware. The speed varies between SoftPC and Orange Micro, depending on the type of network, the amount of network traffic, and the type of PC you use. The cost of the network method will also vary, since you can spend as much money on the PC as you like, or use an abandoned unit gathering dust under a table somewhere.

There are several products that approach the network solution in different ways, but my favorite is Argosy's RunPC, which is a complete package.

In addition to providing network access to a PC, RunPC comes with a DOS disk-mounting utility and file translator software. PC applications can print to Mac printers. You can also connect to the PC with a serial cable (a version is available that comes with a cable) or by modem, although with the latter, I recommend limiting your activities to file transfers and translations.

A similar program is Farallon's Timbuktu for Windows, a cross-platform version of the popular Macintosh screen-sharing program. Macs running Timbuktu can control PCs running Timbuktu for Windows, and Windows users can control a Mac from their PCs. Timbuktu for Windows requires the PC to be running Windows; RunPC can run straight DOS as well as Windows. Timbuktu for Windows currently requires Farallon's PhoneNET Talk hardware and software on the PC. One of the unique features of Timbuktu is the ability to create connection files, which will automatically reestablish the Mac-to-PC linking you have previously set up—just double-click and you're connected. Timbuktu for Windows can also transfer files and perform extension mapping.

If you have a Novell NetWare network, you can buy Novell's Access Server, which is a multiuser DOS application server able to run up to 16 DOS sessions at the same time. This heavy-duty software requires for setup a good knowledge of the workings of NetWare. It is also over five times the cost of RunPC, not including the cost of NetWare for Macintosh. Part of the software that comes with the Access Server is actually a custom version of RunPC that Novell licenses from Argosy.

■ Mixing Macs and PCs on a Network

When PC-to-Mac connectivity occurs frequently and more than a handful of computers are involved, the most convenient choice is to put both Macs and PCs on a common network, or to link existing PC and Mac networks. Multiplatform networks allow more than just the exchanging of files between Macs and PCs—the two types of machines can share each other's *network services* (capabilities made available to large numbers of computer users connected to the network). The sharing of files via file servers is one important network service, but others include printer-sharing, electronic mail, access to a multiuser database, and automatic backup. (See Chapter 7 for a full discussion of network services.)

Network services are handled in vastly different ways on Mac and PC networks. Mac networks use AppleTalk-based services, such as printer-sharing, through the Chooser and AppleShare file sharing, which is based on the AppleTalk Filing Protocol (AFP). Each PC network uses its own proprietary set of protocols, but many provide connections to AFP to enable Mac connectivity. PC networks are generally more complex to set

up and use, more centralized, and more expensive, but offer more built-in security features than does Apple's AppleShare network. This is because AppleShare isn't an entire network operating system, as NetWare and Banyan VINES are—AppleShare is a file-sharing application.

Integrating PCs into a Mac network is a fairly easy procedure, but in a PC-dominated environment with few Macs, it makes the most sense to treat the Macs like PCs. The inner workings of networks will be discussed in later chapters; this section will explore the options available for Mac-to-PC networking.

AppleTalk for PCs

AppleTalk is the networking environment native to Macs (see Chapter 5 for a detailed discussion of AppleTalk). AppleTalk defines everything from the passing of signals along cables to network file sharing and printing services. Adding PCs to an AppleTalk network is a simple matter of adding a network card and some software to the PC.

The network transmitting and receiving hardware built into every Macintosh is called LocalTalk. The advantage of LocalTalk is that it's inexpensive and very easy to set up. LocalTalk is also the connection method for the vast majority of Mac printers. LocalTalk cards are available for AT-bus and Micro Channel PCs from several vendors. Daystar and Farallon are major suppliers of LocalTalk cards for PCs, with their LT200 Connection and PhoneNET Talk products, respectively. Apple left the market when it sold its technology to Farallon. The TOPS FlashTalk card from Sitka is also a LocalTalk card for PCs.

AppleTalk is not limited to LocalTalk, and can run on faster network hardware, such as Ethernet and token ring. The same is true for PCs running AppleTalk software. The most advanced AppleTalk software for PCs is Farallon's PhoneNET Talk PC, which works with Ethernet and token ring cards from most manufacturers. Version 3.0 or later of PhoneNET Talk PC uses NetWare's ODI (open data interchange) driver, a de facto standard for PC network boards. ODI enables PCs to run Novell's IPX protocols simultaneously with AppleTalk (or other network protocols).

The AppleTalk software for PCs from Farallon and Daystar enable PCs to share files with Macs via a file server compatible with AFP. In addition to providing access to dedicated file servers, the software gives PCs access to shared folders on the hard disks of System 7 users, and enables PC users to print to Macintosh network printers. Farallon's PhoneNET Talk for Windows (shown in Figure 2.8) adds a device like the Chooser to the Microsoft Windows interface on a PC for easy connections to Mac printers and AFP-compatible file servers, which appear to the PC as a D drive. Users can set their PCs to automatically log onto AFP file servers when booting up, as is commonly done with Macintoshes. Extension mapping is provided for files

transferred between PCs and AFP-compatible file servers. PhoneNET Talk also gives PCs the equivalent of a Chooser name, which is handy for network managers identifying individual PCs on a network.

Figure 2.8

Farallon's PhoneNET Talk software enables a PC running DOS or Windows to access file servers and printers on an AppleTalk network.

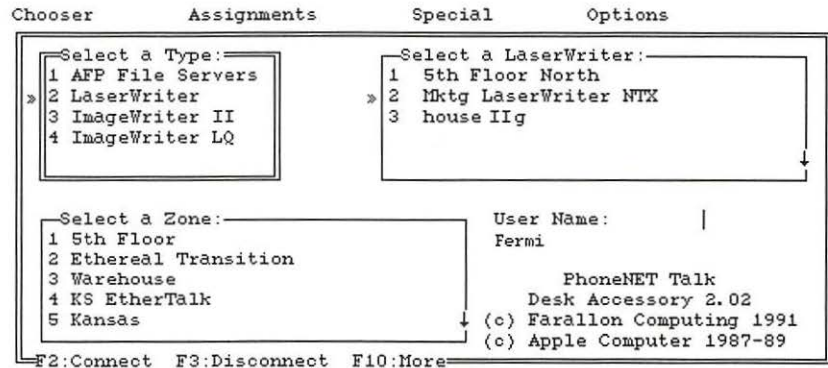

PCs on an AppleTalk network aren't limited to acting as file server clients. Miramar's MacLAN Connect enables you to set up an AFP-compatible file server on a PC running OS/2 or DOS, which can be accessed by Macs and PCs alike.

Passports to Foreign LANs

Beyond the borders of familiar Macintosh AppleTalk is a foreign world of PC networking. With the proper hardware and software—passport products—the Mac is free to travel these strange lands. However, obtaining the passport, that is, installing and setting up, can be fairly difficult compared with standard Mac networking. Be prepared to dedicate a good deal of effort to the task. But once you're set up, you will be able to navigate PC networks as easily as you do Mac networks. In fact, you may not even realize you are connected to a PC network at all.

Like PCs, Macs are not limited to LocalTalk for data transmission. An add-in card or SCSI box can put your Mac on Ethernet, token ring, ArcNet, and other even more esoteric PC networks. That's the easy part. The hard part is configuring the PC servers to accept Macintoshes.

To add Macs to big PC network systems, you usually add an AFP-compliant module to the PC server. Many network vendors, such as Novell and Banyan, have rewritten their network operating systems to support AppleTalk protocols and HFS (hierarchical file system), the method the Mac uses to store files on disks. Other PC network vendors use a more

patched approach to support Macs. In either case, AFP-compliance is becoming so widely accepted among PC network vendors that the Mac can more easily log onto more different types of PC file servers at the same time than can any other computer.

Not only that, but Mac users don't even need to know what type of PC network they are logging onto, or even that they are using a PC file server at all. The procedure for logging onto an AFP-compliant PC server is the same as logging onto an AppleShare server: You select its name from a list in the Chooser. The server appears as an icon mounted on the desktop, like an AppleShare volume.

The most important passport product is Novell's NetWare for Macintosh, an add-on to Novell's market-dominating, soup-to-nuts suite of PC networking products. NetWare for Macintosh enables Mac users to share files with PCs on NetWare file servers, which run 386-based PCs. Although setup usually requires a certified NetWare consultant, the Mac user interface is very friendly. In addition, the performance of NetWare for Macintosh has been shown to be very impressive in MacUser Labs tests.

For environments with a small number of Macs, Insignia's SoftNode and Dayna's NetMounter are much less expensive ways for a Mac to join a Novell network. SoftNode works with SoftPC to fool NetWare into thinking that the Mac is actually a PC logging in. The drawback is, the user gets the command-line interface of a Novell PC client instead of the AppleShare-like interface. Not so with Dayna's NetMounter, which gives you standard Chooser access to a Novell server and mounts it on the desktop. Neither of these products requires installing any software on the PC running the NetWare server.

Although Novell NetWare is by far the most popular PC network, there are others that offer Mac connectivity. Like Novell, Banyan has done a good job of rewriting its network server, VINES (version 5.0 or greater) to accommodate Macs. Mac connectivity comes in the form of two VINES add-ons, the VINES Option for Macintosh for file and print services, and VINES Mail for Macintosh for electronic mail.

VINES is accessed through the Chooser, but differs from AppleShare and Novell NetWare in one respect: The VINES servers listed in the Chooser are *logical* services instead of physical devices. That is, instead of seeing the actual name of a printer or a file server hard disk, you see the VINES name of a network service set up by the network administrator.

VINES is also noted for its wide-area networking (WAN) capabilities, and makes it easy for a non-technical Mac user to connect with VINES sites in other locations. VINES can deliver AppleTalk data to remote sites, so that a file service in an office across the continent will appear in your Chooser. (See Chapter 13 for a more detailed discussion of WANs.)

Microsoft LAN Manager, version 2.1 or greater, can accommodate Mac clients with the addition of the MS Services for Macintosh add-on. LAN Manager is based on 3+Open, which Microsoft bought from 3Com. Although you may hear the term *network operating system* to describe NetWare and VINES, the term technically doesn't apply to LAN Manager server, since it runs on top of the OS/2 operating system. Unlike Novell and Banyan, Microsoft's LAN Manager uses two different server processes for Macs and PCs, which means the network administrator will need to maintain two lists of users and passwords. A similar product is IBM's LAN Server, which is based on Microsoft's LAN Manager, although it is not completely compatible with it. Version 2.0 or greater will support Macs. Like LAN Manager, LAN Server sits on a PC running the OS/2 operating system.

Another solution is to connect Mac and PC networks with a gateway product. MacLAN Connect from Miramar Software is a gateway running on a PC that connects a Mac network to a variety of PC networks, such as to IBM's OS/2 LAN Server, Novell NetWare, and Microsoft's OS/2 LAN Manager. Mac and PC users can exchange files and electronic mail, and share printers. Extension mapping is used so that Mac users can double-click to open PC files. The PC running MacLAN Connect can be administered from any Mac on the network.

■ Printing to PC Printers

Being able to use an existing PC printer means you can spend part of your printer budget on other peripherals for your Macs. Since there are more printers made for the PC than for the Mac, and they're usually cheaper than Mac printers, you're more likely to have PC printers available in a mixed environment. Although their print quality is often not as high as Mac printers, PC printers are adequate for most business text documents. Also, if you are in the market for a new printer and have Macs and PCs, you should keep an eye out for features that make it easy to accommodate both machines.

The PC printers you are most likely to run across are Hewlett-Packard LaserJet laser printers and Epson dot-matrix printers. Fortunately, there are several inexpensive ways for the Mac user to make use of these and other DOS printers. You can connect a single Mac to a single printer, or share a printer with other Macs and PCs. Sharing a printer can be accomplished with a printer-sharing device or with a network.

There are two parts to all of these solutions: hardware and software. The hardware includes cables, printer-sharing boxes, and network interface cards. Printer driver software is used to support the type of printer as well as the connection. The software also is used to determine the language the Mac will use to describe the text and graphics to the printer.

One-on-One

A single Mac-to-printer connection is usually made through the Mac's printer or modem port. You can connect to a PC printer's serial port, or to its parallel port if your cable and software can do a serial-to-parallel conversion. Cables are bundled with the special software and printer drivers your Mac requires to print to a PC printer. Top printing speed is typically 19,200 bits per second (bps), compared with LocalTalk's 230,400 bps.

Leading packages include GDT Softwork's JetLink Express, Insight's MacPrint, and Orange Micro's Grappler, which all offer inexpensive yet complete solutions. Most packages support Hewlett-Packard DeskJets, DeskWriters, and LaserJets. The Grappler supports a wide range of dot-matrix printers as well.

Although these packages implement their driver interface in slightly different ways, all use the Chooser to select a PC printer. MacPrint and JetLink Express install a Chooser driver icon (called an "RDEV") for each type of PC printer, as shown in Figure 2.9. The Grappler uses Apple's ImageWriter LQ RDEV for any printer it supports.

Figure 2.9

GDT Softwork's JetLink Express adds a Chooser driver for each PC printer.

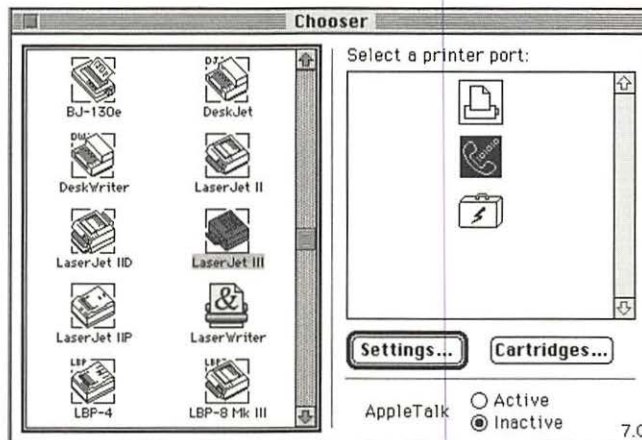

Since none of these packages use Apple's LaserWriter Chooser driver, you can't use the Mac's PrintMonitor spooler, which is part of the Apple LaserWriter driver. Without a spooler, your Mac is tied up until the print job is finished. Grappler compensates for this by supplying a built-in print spooler accessible through the Control Panel. MacPrint and JetLink Express do not have spoolers, but both are compatible with SuperLaserSpool from Fifth Generation Systems, which you can purchase separately.

Printer-Sharing Devices

Printer-sharing devices are popular in the PC market, where shared network printers are not as common as in the Mac market. These devices can come in the form of a stand-alone box with multiple connectors for PCs and one or two connectors for printers, or as add-on cards for printers (as shown in Figure 2.10). The stand-alone boxes usually support more than a dozen PCs, while the printer cards typically support a handful. Each configuration is basically a switch with a RAM buffer that fools the printer into thinking that it is the computer sending it jobs. The more PCs attached, the bigger the RAM buffer needs to be. Several printer-sharing devices support Macs running the printer driver software mentioned above. These include products by Extended Systems and AST.

Figure 2.10

A printer-sharing device connects multiple PCs or Macs to a printer using serial or parallel connections.

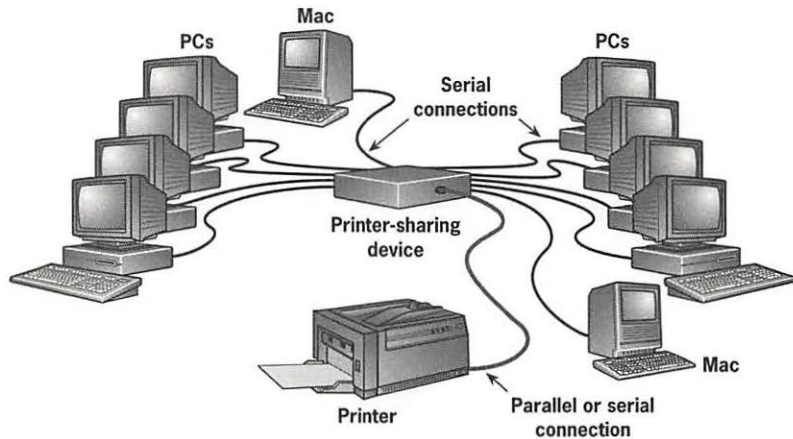

The setup in Figure 2.10 is not a network, since the computers can't see each other; they can only see the printer-sharing device. These devices are an economical solution if you have a small number of Macs and many PCs. Since they have a limited number of serial or parallel ports, printer-sharing devices don't allow for growth, as a network does. In addition, their top speed is usually 115,200 bps, which is slower than a network.

LocalTalk for PC Printers

The next step up from a printer-sharing device is to put the DOS printer on a network. A network allows many more users to share a printer, and is much faster than either serial or parallel connections.

LocalTalk has long been the network-connection standard on Mac laser printers. Most PostScript printers support LocalTalk, which is becoming

more common for PC printers as well. Hewlett-Packard offers LocalTalk add-in options for many of its LaserJet printers, and third-party vendors also offer LocalTalk cards for PC laser printers. Extended Systems has one of the most extensive selections of LocalTalk cards for PC printers.

Most LocalTalk cards can be installed in PC printers in a matter of minutes with just a screwdriver. In addition to the LocalTalk port, you'll often get a serial and a parallel port, to which you can connect PCs. Unfortunately, in Hewlett-Packard's standard upgrade, you can only use one of these ports at a time, and you'll have to reconfigure the printer each time you switch ports. If you are shopping for a new printer to be shared by Macs and PCs, investigate a feature called intelligent port switching, or I/O switching. These printers come with LocalTalk, serial, and parallel ports and will automatically switch between them as printer jobs come in from Macs and PCs.

You can also add an external device that bridges a PC printer to a LocalTalk network. Extended System's BridgePort is one such box that takes advantage of the Mac's built-in LocalTalk port while connecting the PCs to a printer in a low-cost manner. A LocalTalk port connects to a network full of Macs, and the box's serial and parallel ports can connect to an individual PC or to a printer-sharing device. As Figure 2.11 shows, the printer can then be connected to the printer-sharing device or to BridgePort. Connecting the printer to the printer-sharing box favors the PCs in performance, while connecting it to BridgePort favors the Macs.

Another similar, but less flexible, device is Shiva's NetSerial. It will take any serial device and make it available on an AppleTalk network via a LocalTalk connection.

Ethernet, a faster network transport alternative to LocalTalk, is also beginning to appear on higher-end printers. The LaserWriter IIg introduced in the fall of 1991 was Apple's first printer with an Ethernet port. Macs equipped with Ethernet ports and the correct driver software can make use of PC printers with Ethernet ports. Several products are available that enable networks of Macs to print to PC printers connected to Novell NetWare or other PC LANs. In addition to the passport products discussed in the previous section, there are inexpensive products such as Insight's Mosaic which work for individual Macs.

Printer Languages

In addition to making the connection, you need to consider what printer language you're going to use. For the Mac user, the easiest, most natural language is PostScript, the standard page description language used by every Mac application for text and graphics. PostScript offers more digital fonts than any other standard digital type library. PostScript fonts are outline fonts; that is, the PostScript language mathematically describes the outline of

each character. Characters in outline fonts are the same, regardless of size. By contrast, bit-mapped fonts describe characters by a series of dots and can degrade in quality when scaled to different sizes. The standard Mac method of printing is to send PostScript descriptions of the file over LocalTalk to a laser printer. Fortunately, PostScript is becoming popular on PCs and workstations, and many PC printers support it.

Figure 2.11

Combining a LocalTalk network of Macs with a printer-sharing device can be done with Extended System's BridgePort.

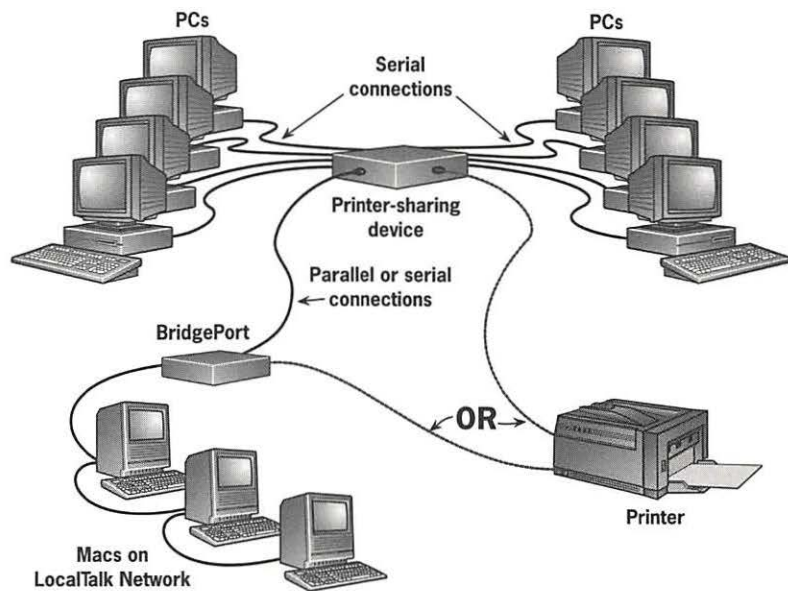

Hewlett-Packard sells PostScript font cartridges for its LaserJets. These are a little pricy, but you can pick up third-party PostScript or PostScript-clone cartridges for less. For printers without PostScript support, you can emulate PostScript with software that runs on the Mac. This method is very, very slow over LocalTalk, but is available at a fraction of the cost of a PostScript cartridge. Emulators can also be used over a serial cable, but only if you're not in a rush. Using a serial connection set to 19,200 bps, Freedom of Press, one of the best PostScript emulators, takes about five times longer to print than MacPrint over the same serial setup.

If you don't use PostScript, you'll need to use one of the software packages described above under "One-on-One." These packages will work over a network, as well as over a serial cable. The page description language varies among these packages. MacPrint emulates QuickDraw, the language that the Mac uses to draw on screen. (Non-PostScript Mac printers also use

QuickDraw as their printer language.) MacPrint includes a utility that creates bit-mapped screen fonts that correspond to HP LaserJet PCL (printer command language) cartridge fonts. (Several dozen PCL font cartridges are supported.) The screen fonts created with MacPrint can be installed in the Mac's System file. JetLink Express takes a different approach, and has its own set of outline fonts. These don't emulate PostScript in any way, but do retain their quality at most point sizes.

■ Looking Ahead

In this chapter, I've detailed non-network solutions for connecting to the world of PCs, while just listing network opportunities available for PC-to-Mac communications. Before diving head first into LANs and WANs, we need to consider one important connectivity area that is not necessarily network-related: telecommunications. Whether at your desk or on the road, a Mac connected to a telephone line is one of the most indispensable connectivity combinations you'll ever use.

- *Built In: The Mac Modem Port*
 - *Choosing a Modem*
 - *Understanding the Software*
 - *Exploring the World of On-Line Services*
-

C H A P T E R

3

Telecommunications

THE COMBINATION OF COMPUTERS AND TELEPHONES IN A movie plot usually involves a hacker sitting in front of a keyboard at 3 a.m. breaking into classified material. Although far removed from everyday experience, one aspect of this scene rings true: The hacker is alone and off site. Telecommunications removes the restriction of proximity from connectivity. But instead of a method of mischief, telecommunications is a resource for research. With a modem and simple software, you can access mainframes, join vast computer networks, and transfer files from anywhere in the world—even from a desert island—as long as you have a telephone line.

Telecommunications is the computer equivalent of a phone conversation, except the caller and receiver are modems connected to a computer running special software. The modem dials a phone number and another modem answers the call. Once a connection is established, a two-way conversation between the computers can begin.

A modem by itself has no intelligence; it takes its orders from software. You type a telephone number, and the software tells the modem what number to dial and when to dial it. Software also provides the reasons why we can telecompute: It emulates mainframe terminals, compresses and transfers files, and sends electronic mail messages to people in distant cities. Software also connects us to any of several dozen on-line services that offer databases of information and a method to contact experts in a variety of fields.

Telecomputing also can be quite an inexpensive proposition. Modems often cost less than hard disks, and good telecommunications software can cost next to nothing. Mac users, however, must pay another price—the need to venture outside standard Mac interface conventions. Usually, knowing one Mac program gets you through other programs without the need for picking up a manual. Not so for communicating with a modem, a task marked by the language and conventions of hackers and mainframe developers. Much progress has been made by product developers in certain areas, but you'll still need to know what is going on underneath the Okay button, or you just may find yourself staring at a prompt that is waiting for you to type in a command.

Built In: The Mac Modem Port

Since the original 128k model, all Macs have a modem port, identified by an icon—a telephone handset—embossed in the Mac's plastic case. The modem port, like the printer port, is a *serial port*, meaning that data is sent one bit after another on a single data line. It is also the Mac's slowest port, with a maximum speed of 57,600 bits per second over a modem. In addition to modems, the modem port can be used for other serial communications, such as connections to hand scanners or to PCs, as described in the previous chapter. However, it would be better to choose peripherals that connect via methods such as an internal add-in card, a local area network connection, or the Mac's SCSI port (short for "small computer system interface," the Mac's standard method for connecting hard disks).

You can also connect a modem to your Mac's printer port, but this port is usually used for connecting to a LocalTalk network. Without special additional networking software, the modem port has no network capabilities. Telecommunications software will let you select either the modem or the printer port from which to run a modem.

Two types of connectors have been used on the Mac's modem port. Since the release of the Mac Plus in 1986, modem and printer ports have had the circular DIN-8 connectors. Before that, Macs had a bigger DB-9 connector (see Figure 3.1). Although the modem and printer port connectors are identical, you can't always use the same cable for both (see "Selecting a Modem Cable," later in the chapter).

Figure 3.1

Mac serial port connectors: the current DIN-8 and the older DB-9 connector

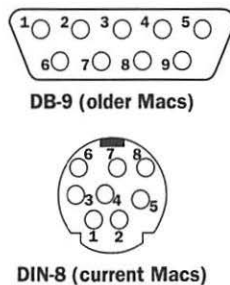

■ Choosing a Modem

Despite increasing speed and reliability, basic modem technology hasn't changed much from the 1960s. A *modem* (from the tech-speak *MODulator/DEModulator*) converts a computer's digital signals into audible tones that the modem transmits over a standard analog telephone line. Modems can plug into your Mac or sit inside of it, and usually come with an RJ-11 jack in which you plug a standard telephone cable. A modem connected to a Mac can be a personal modem for your use only, or a network modem shared by everyone on a network.

Modem speed is the primary factor to consider when buying a modem. You'll see modem speed expressed in terms of baud and bits per second, but the two terms are not interchangeable. *Baud* refers to the number of signal changes made per second; *bits per second* (bps) refers to the amount of data transferred. The bps rating, which is usually higher than the baud rate, is the more useful piece of information. In any case, modem speeds are still far slower than any local area network, so the faster the modem, the better. A faster modem usually slows down to communicate with a modem running at a slower speed.

I don't recommend buying anything slower than a 2,400 bps modem; these are also the most common. Slower modems are available at bargain prices but will cost you more in on-line service fees, telephone bills, and antacid pills. Although 4,800 bps modems are available, the most common

step up from 2,400 bps is 9,600 bps. These can cost twice as much as 2,400 bps modems, but it's well worth the investment if you are transferring files to another 9,600 bps or faster modem on a regular basis. You can get a faster modem yet, running at 19,200 bps, but you'll still rarely find another 19,200 bps modem on the other end of your telephone line. A file that takes two hours to transfer with a 2,400 bps modem will take only 15 minutes to transfer at 19,200 bps. Modems running at 19,200 and 38,400 bps are most useful for two or more sites that communicate mainly with each other.

Although it seems that modems will forever keep increasing their transmission rates, they can never reach the maximum speed of the Mac's modem port due to line noise, which is always present. Some telephone lines are too noisy to handle higher-speed modem transmissions; the noise causes the modems to drop to lower speeds. This effect is called Shannon's Law: A maximum transmission speed is set based on a line's characteristics.

For today's telephone systems, this top limit is about 38,400 bps. Dennis Hayes, of modem giant Hayes Microcomputers, once compared this limit to the speed of light: You can't pass the barrier, and the closer you get to it, the harder it is to get there.

An Alphabet Soup of Standards

Modems are categorized by an array of labels that sound more like formulas for rocket fuel than names of computer peripherals. These numbers identify the communications protocols that the modems use. Modems follow *protocols*—conventions that communication devices use to understand each other—to determine what types of signals to listen for and how to respond to them. Most modems use industry-standard protocols, allowing them to talk to modems of different brands. Modem vendors use these protocols in their advertising, so it's a good idea to familiarize yourself with them before shopping for a modem.

Three basic types of protocols are used with modems: modulation (the basic sending and receiving of data), error correction, and data compression (see Figure 3.2). All modems use modulation protocols, which are required for error correction protocols, which in turn are required for data compression. Error correction is particularly important for transferring files: These protocols ensure that noise on telephone lines doesn't garble data by retransmitting data until it gets through intact. Built-in data compression allows a pair of modems to communicate at data-transfer rates much greater than their bps rating. Built-in compression and decompression is done automatically, without the need for user intervention.

Modulation Protocols

Industry-standard modulation protocols first came out of Ma Bell in the early 1960s. Today, the Bell 103A protocol is used in 300 bps modems, and Bell 212A is used for 1,200 bps modems. With the advent of personal computers, a suite of proprietary standards called MNP (Microcom Networking Protocols) became de facto standards. Microcom licenses the MNP standards to other modem manufacturers. By the mid 1980s, an international industry group, CCITT (Consultative Committee on International Telegraph and Telephone) had created another set of protocols. Many modems today support both MNP and CCITT protocols.

Figure 3.2

There are three types of modem protocols, all running at different speed ranges.

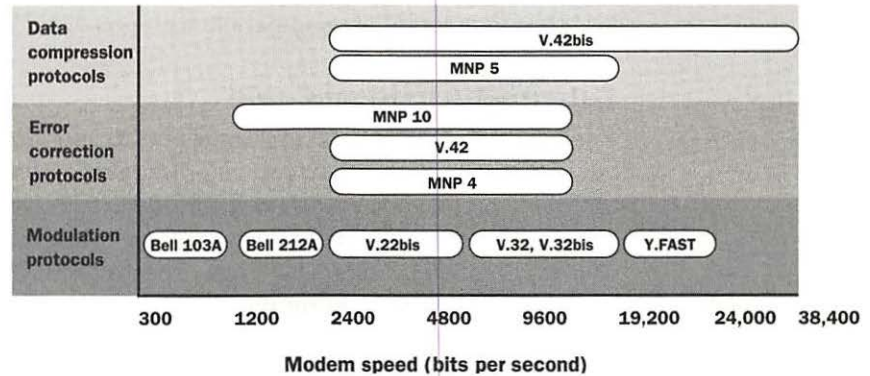

The CCITT modulation protocol for 2,400 bps modems is called V.22bis. It is faster than earlier protocols because it uses a phase shift modulation technique to send signals, whereas the Bell standards use a frequency shift modulation, which can't generate higher transmission speeds. The CCITT modulation protocols for 9,600 bps modems are called V.32 and V.32bis, the latter being a faster protocol that allows transmission up to 14,000 bps. These protocols allow high-speed modems to revert to lower speeds when they communicate with slower modems. CCITT is working on a new modulation protocol called v.FAST, which allows transmission between 19,200 and 24,000 bps.

Error Correction and Compression

In addition to the modulation protocols, an increasing number of modems support error correction and data compression. The CCITT error correction standard is V.42, which incorporates the older MNP 4. The data compression standards are V.42bis and MNP 5. Data compression works with V.42bis or MNP 5 modems at both ends; otherwise, the transmission will occur without compression. The two protocols are not totally equal, however, since V.42bis

data compression is faster than MNP 5. MacUser Labs has shown that 2,400 baud V.42bis modems can run close to 9,600 bps, and 9,600 bps V.42bis modems can run to nearly 38,400 bps. The slower MNP 5 protocol on a 2,400 baud modem can run as fast as 4,200 bps. When talking to a MNP 5 modem, a V.42bis modem slows down to MNP speed.

In October, 1991, a new Microcom error correction standard, MNP 10, became available. MNP 10 was developed to make cellular modems practical by handling the adverse line conditions common with cellular communication. Cellular modems, like cellular telephones, communicate via radio waves, instead of via telephone cable. MNP 10 is a flexible protocol; it makes multiple attempts to open a link, and automatically shifts its speed between 1,200 and 9,600 bps, depending on the quality of the connection. The size of the data packet—the unit of information sent at one time—is changed on the fly. MNP 10 modems are compatible with non-MNP 10 modems.

Selecting a Modem Cable

You'll have to look beyond the connectors to find the right cable for your modem. Although there are certain printer cables that look like modem cables, chances are they won't work. Modems running at a straight 2,400 bps and slower can use the standard Macintosh modem cable from Apple or your dealer. For modems running at higher speeds or for those using data compression, you need to be more careful. These modems require a special cable that can handle hardware *handshaking*, an exchange of signals that enables two devices to acknowledge each other's state. Hardware handshaking controls the flow of data between the Mac and your modem, so that the Mac doesn't send data at too slow or fast a rate. The standard Mac-to-modem cable supplied by Apple and dealers isn't wired to the *flow control pin*, the connector pin that carries a signal that tells the Mac to stop or start sending data.

High-speed modems that use cables without hardware handshaking will work, but not at high speeds, thereby wasting the extra money you spent on the fast modem. If your modem didn't come with one, you can buy a handshaking cable or make an adaptor for your current cable for less than a quarter of the price of one you could purchase—and just a half an hour of your time (see Figure 3.3).

It's easiest to make an adaptor cable that sits between your modem cable and the 25-pin connector that comes on most modems. You'll need a soldering iron and solder, a 25-pin connector plug and socket, and 6 inches of 6-pair Belden-type 9535 or 9536 wire. These can be found at electronics supply stores or through mail-order houses. Connect pin 1 on both ends to the cable shield. Run pin 2 to pin 2, pin 3 to pin 3, pin 5 to pin 5, and pin 7 to pin 7. On the plug that goes into the modem, tie pin 6 to pin 20. On the socket that goes to the Mac cable, tie pin 20 to pin 4.

Figure 3.3

The connections necessary for making a jumper cable for hardware handshaking

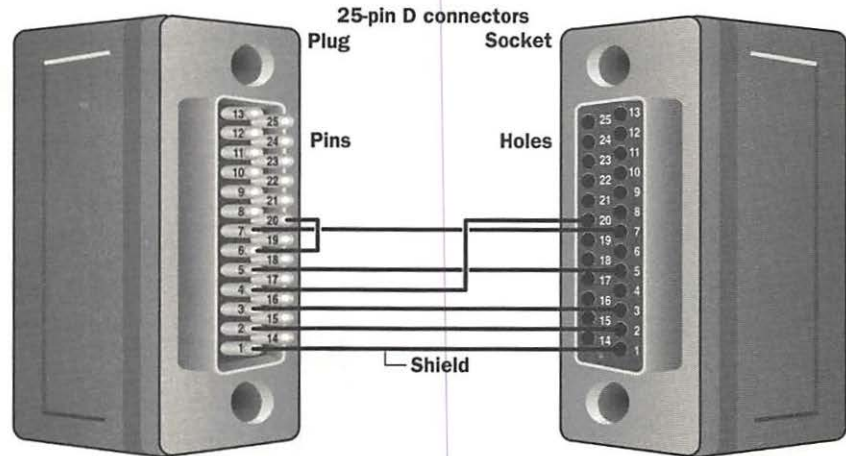

Fax Modems

Fax modems, that is, modems with built-in fax capabilities, combine a data modem with the ability to send and sometimes receive faxes right from your Mac. Usually the fax software that comes with a fax modem enables you to send faxes from within your word processing, spreadsheet, or graphics program with a single menu command, similar to the way you print a document (see Figure 3.4). Compare this with the traditional method of sending a fax: You print out a document, take it to a fax machine down the hall, dial a fax number, run your paper through the fax machine, and throw the printout away. In addition to saving time and paper, a fax sent from a fax modem is better in quality. The sending of a fax is a background task on your Mac, so you don't have to wait for a fax to be sent before you start working on your next memo.

Fax modems that can receive as well as send can sometimes turn on your Mac when a fax is incoming, so you don't have to leave your computer running 24 hours a day in order to receive faxes. One thing to keep in mind is that receiving a fax on your Mac is not the same as receiving a word processing file via electronic mail. What a fax modem receives is not a text file, but a picture of a text file, the equivalent of a scanned image. If you want to convert this picture to editable text, you have to use OCR (optical character recognition) software. Using OCR software is far from a one-step process, so if you need text, have the sender transmit a word processing file instead of a fax. Receiving text documents by fax is appropriate when you don't need editable text, but just need printed information.

Figure 3.4

Sending a fax with a fax modem can be as easy as printing.

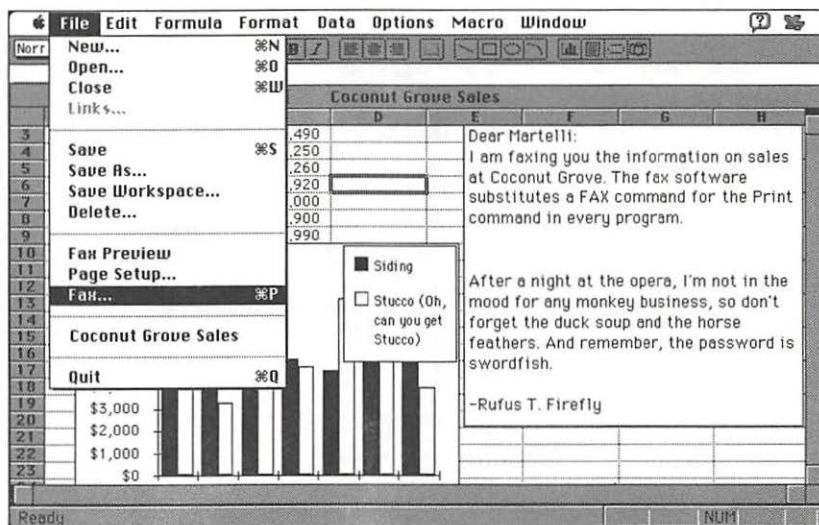

Faxes are bit-mapped pictures so they are usually bigger than text or graphics files, taking longer to send. Because of this, fax modems will often transmit faxes and data files at different speeds. The minimum speed you should consider for data transmission is 2,400 bps; the minimum speed for fax transmission should be 9,600 bps.

Enveloping—the ability to send several fax documents in a single transmission—saves you from having to make multiple calls or from having to cut and paste material into a single file. An ancillary feature is the ability to send a single fax to multiple destinations, which allows you to continue working on your Mac while the fax modem makes several phone calls in the background. An automatic retry feature is welcome in this situation, so the fax modem will call back a number when transmission is interrupted. A nice money-saving feature is delayed sending, which will take advantage of off-hour telephone rates.

In addition to speed, print quality can vary. Most fax modems support two bit-mapped resolutions, standard resolution, 203 by 98 dpi (dots per inch) and fine resolution, 203 by 196 dpi. However, both resolutions are higher than the standard Mac screen resolution of 72 dpi. Since faxes take a picture of what's on screen, they'll normally create a fax at 72 dpi, which can make small type hard to read. Make sure your fax software can magnify received pages in order to read small type comfortably.

Although you can't always control how people send you faxes, you can overcome this limitation when sending faxes by carefully choosing how you

use fonts. You can significantly improve the quality of faxes you send by using Apple's True Type fonts, or by using Adobe Type Manager (ATM) with Postscript fonts. Either of these methods capture (or *rasterize*) the page image at 216 dpi, three times the resolution of the 72 dpi screen. This smooths out curves on characters, particularly at large and small sizes. Another strategy is to use LQ (letter quality) fonts, such as those that come with the ImageWriter LQ printer. This will work only if you install fonts that are three times the size of those used in your document. For instance, if you use 12-point Helvetica, the fax software needs 36-point Helvetica. The fax software will rasterize at the higher-sized font and scale it down, thus getting the same effective rasterizing resolution as ATM (216 dpi).

Network Modems

Another type of modem to consider is a network modem (or network fax modem) which is available to any Mac on a local area network (see Figure 3.5).

Like a printer, a network modem can be plugged in anywhere in a network and doesn't need to be connected to a Mac. A network modem can be accessed through the Chooser the same way a printer can. A network modem is a more economical solution than providing every user with a modem. However, a network modem can be slower than a personal modem if the network has heavy traffic, for example, a very large graphics file printing. In a busy office, it makes good sense to make network modems available for those with occasional telecommunications needs, and personal modems for heavy telecommunications users.

Network modems also allow you to dial into an office network from a remote site using a standard modem. This allows a user working at home to access the file servers and printers on the office network. The speed will be many times slower than it would be at the office, but the network functionality is there. You can also connect two networks, so that users at each location can access each other's printers and file servers.

Several types of network modems are available, but Shiva has the most Macintosh experience with its NetModem series. Network modems use the same modulation, error correction, and data compression standards as personal modems.

■ Understanding the Software

Just as the modem makes the connection between the Mac and the telephone lines, telecommunications software makes the connection between the Mac and you, the user. The telecommunications software tells the modem to dial a phone number, informs the Mac when a connection has been made, and enables you to send and receive files and messages.

Figure 3.5

A network modem is available to anyone on a network and can be used to access a network remotely.

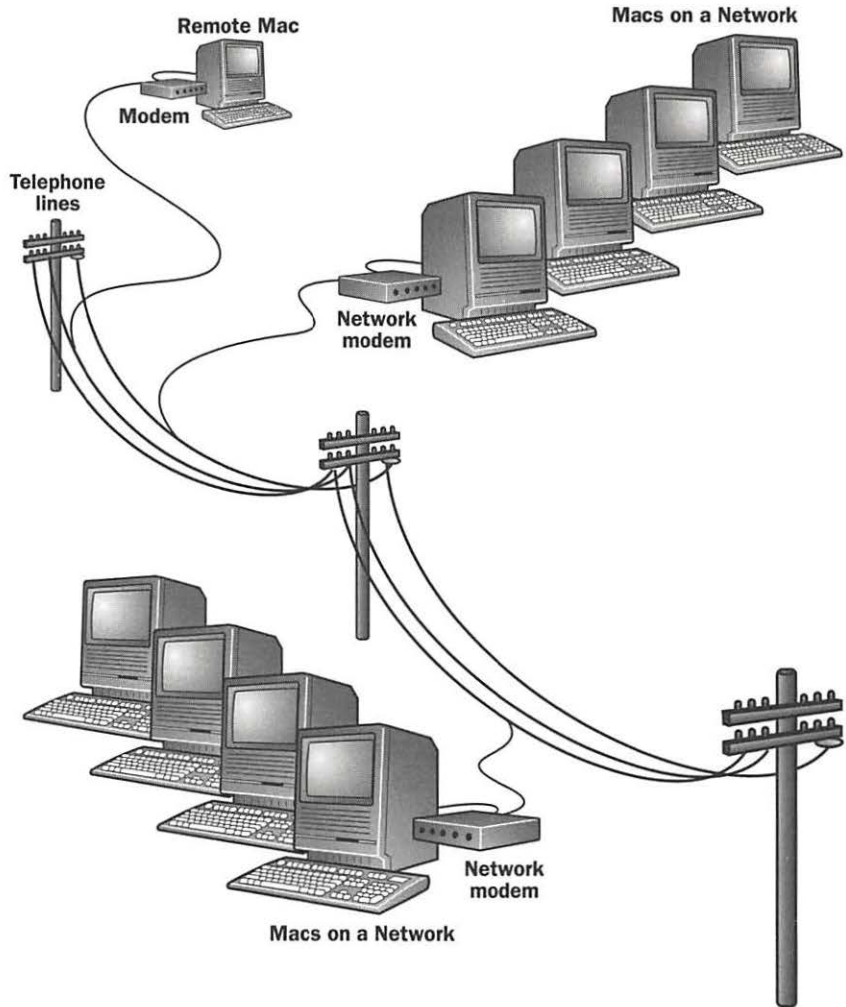

These software packages span the entire spectrum, from shareware to full-featured commercial powerhouses. Shareware works on the honor system: You're welcome to try the program out, and if you like it and find it useful, you're expected to send the author a small fee, usually in the range of \$10 to \$40. No one will catch you if you cheat, but paying the fee encourages programmers to keep coming up with handy utilities. For example, Red Ryder was a shareware standard for years, until it became a beefed-up commercial product, the Freesoft Company's White Knight. ZTerm is a clean and powerful shareware program that is hard to beat. For a full-featured

commercial package, Software Ventures's Microphone II and Hayes's Smartcom II come with many bells and whistles. The package you pick is independent of the software, modem, or computer at the other end of the connection.

Macintosh users often find telecommunications programs somewhat user-unfriendly because they require knowledge of non-Mac terminology and technology. For instance, before you make your first call, you'll have to choose the parameters of your transmission (see Figure 3.6). The default settings usually work, but your software manual will tell you when special settings are required. Fortunately, you only have to set up once for each type of connection you intend to make, since most telecommunications software lets you save the settings that correspond to different phone numbers.

Figure 3.6

Setting up modem communications in Microphone II

Communications Settings

Baud Rate

50 200 1800 7200
 75 300 2000 9600
 110 450 2400 19,200
 134.5 600 3600 38,400
 150 1200 4800 57,600

Bits per Character: Stop Bits: Parity:

Modem Driver:
 ↑
 ↑
 ↑
 ↓

Connection Port:
 ↑
 ↑
 ↑

Hardware Handshake Strip 8th Bit

You'll also have to choose a modem driver, sometimes referred to as a CCL file (communications control language). The telecommunications application will ask you to pick a driver that corresponds to your modem when you set up communications. Modem driver files can usually reside anywhere on your hard disk, so there's no need to clutter your System Folder with these files.

And, you're not in the clear after you've set up. You'll still be dealing with non-Mac terminology when you type messages and transfer files, as well.

Terminal Emulation

Most telecommunications programs offer basic terminal emulation features, which simulate the behavior of mainframe terminals inside a Mac window. The most common terminals emulated are Digital Equipment Corporation's VT100 emulation and standard TTY (teletype). You can also buy more

extensive terminal emulation products specifically designed for interfacing with mainframes; these will be discussed in later chapters.

Typing at a terminal (or emulator) is not at all Mac-like. What you usually get is a monospaced font (such as Courier), 80 characters across the page. You have to forgo such standard Mac techniques as using the mouse to insert a cursor in the middle of text: You usually can only type at the end of line; the Backspace key moves the cursor back, but doesn't erase characters from the screen. You can often use Copy and Paste, but you can't always perform the Mac's Cut function.

As you type, the text will move up the screen, keeping the cursor in the same place at the bottom of the screen. Most telecommunications software uses a scroll-back buffer, which saves the text that scrolls off the screen at the top and lets you scroll up to look at it. Terminal emulators can also remap Mac keys to behave like keys on a terminal's keyboard.

Scripting

Most telecommunications programs offer some degree of scripting for simplifying repetitive tasks. Scripting reduces a multistep task to a single command, like a macro in a spreadsheet. Simple scripts can often be created by turning on a recorder, which follows the steps you make. More complicated scripts are created by typing in commands.

A simple script would, for example, dial another computer, log in an account number and password, collect data residing in a preset area, and then log off. Microphone II and Smartcom II enable you to create on-screen buttons that will activate these types of scripts. You can also set up menu commands that log into different mainframe accounts and on-line services, and set up address books of users with personal modems, or groups of subscribers to on-line services. If you call the same on-line services every day, many telecommunications programs will let you create scripts that will call multiple numbers and download information. Even the shareware program ZTerm has a scripting feature called Queue dialing, which will call a list of numbers until you connect to one.

You can create scripts that go beyond simple macros by using programs like Microphone II and Tempo II, which offer scripting languages that border on application development environments. For instance, an organization's communications expert can set up an interface to distribute to nontechnical users, complete with buttons and menu items that perform company-specific procedures. Microphone II's scripting language is close to a full high-level programming language that calls routines from macro languages of other programs.

File Transfer

Sending files over a modem is one of the more useful features of all telecommunications packages. You can send and receive files to and from Macs, PCs, and mainframes. When sending or receiving a file, you have to specify which *file transfer protocol* standard you want to use. These protocols determine how the software running on each computer is going to send and receive a file. (This is not to be confused with the *modem protocols* discussed above, which determine how the modems talk to each other.) There are basically four file transfer protocols to choose from—XModem, YModem, ZModem, and Kermit—although not all are supported by all on-line services or telecommunications software.

Xmodem is one of the most widely used file transfer protocols for Macs and PCs. Just about all on-line services support it. Developed in 1977, the XModem protocol automatically checks errors and corrects them by resending the incorrect portion of the file.

YModem is a variation of XModem that allows multiple files to be sent at one transmission. YModem-G is a faster version of YModem, but doesn't have error correction (the transfer is stopped if an error is found). YModem-G is best used with V.42 error-correcting modems.

ZModem is the most advanced of the file transfer protocols for personal computers. In addition to the ability to send multiple files and retransmit unsuccessful data, ZModem offers the best speed and reliability. ZModem also supports autodownloading, which notifies the receiving telecommunications software of an impending file transmission and enables it to start receiving without user intervention. In addition, if the telephone link is interrupted in the middle of a transmission, the ZModem protocol will allow some software to resume the file transfer where it left off. This is very handy if you're transferring big files that take an hour to transmit.

The fourth file transfer protocol, Kermit, is a specialized protocol used for moving 8-bit data communication paths that allow only 7-bit data, usually text only. It is a good transfer protocol to try if nothing else works, particularly if you are sending a file to a computer other than a Mac.

In addition to a file transfer protocol, you'll also have to choose a *file format*, which determines the structure of the file while it is being transferred. Mac users will use MacBinary most of the time. MacBinary retains a file's "Macness" during a transmission, such as its document icon, any Finder information, and file type and creator (see Chapter 2). MacBinary will transmit a file's resource fork, the part of a Macintosh file that stores instructions for applications. Other file formats for telecommunications are Text and Binary, which only transfer the text component of a Mac file, which is called the data fork.

Compression Utilities

Transferring files over a modem is one of the most time-consuming activities you can do with your Mac, even with high-speed modems. Therefore, it's a good idea to get into the habit of using a file-compression utility on files before transmitting them. This is common practice in telecommunications, and files available for downloading from on-line services are stored in compressed form. You may have a problem with some MNP 5 modems which can't recognize a file that is already compressed. They may waste time trying to compress the precompressed file (which is not possible); this can sometimes take longer than sending an uncompressed file. The V.42bis modem can tell if a file is precompressed and does not bother compressing it.

In addition to saving time, another benefit of compression utilities is the ability to compress multiple files into a single archive file (see Figure 3.7). Archiving is not redundant with the file transfer protocols mentioned in the last section which also can send multiple files, but complementary. You might, for instance, use YModem or ZModem to send several archive files in one transmission. Archive files also keep related files together, such as a Read Me file that goes with a shareware file.

Figure 3.7

Compression utilities like StuffIt let you compress multiple files into one archive file for faster and easier transmission.

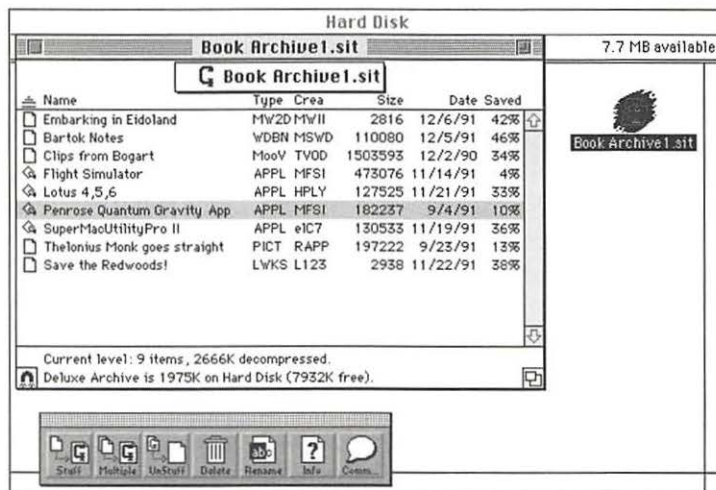

Compression utilities are shareware or inexpensive commercial utilities. Shareware utilities distributed by user groups and on-line services work just fine, but don't come with warranties or technical support. The standard Mac compression utility for many years was StuffIt, a shareware program written by whiz kid Raymond Lau.

StuffIt has lost some of its preeminence because new programs have come out with more sophisticated features. StuffIt evolved into Aladdin Systems's StuffIt Deluxe, which offers sophisticated scripting capabilities to automate compression. The shareware version is still available, but is now called Stuffit Classic. Compact Pro is a popular shareware utility that compacts files tighter than most other programs. A very useful feature of these programs is the ability to create *self-extracting archives*; that is, the files decompress when double-clicked, so the receiver doesn't need that compression utility to open the files.

Another type of utility automatically compresses designated files on the hard disk. The process is completely transparent, and compressed files can be decompressed and opened with a double click, worked upon and saved, then closed, and recompressed without the user knowing that the files are being compressed and decompressed. Salient Software's AutoDoubler and Aladdin's SpaceMaker are good examples of this type of utility. While very useful for storing a lot of data on a hard disk, these utilities are not convenient for sending files over a modem.

■ Exploring the World of On-Line Services

National on-line services are dispensers of vast and varied stores of information. Through your modem you can access business and finance news and information, technical information about computers or consumer electronics, and libraries of published articles and applications. On-line services also act as a conduit to people with similar interests. On an electronic bulletin board (also called a bbs or forum), subscribers seek help and debate issues. On-line services also offer private electronic mail and live conferences with multiple participants. Hundreds of free local stand-alone electronic bulletin boards also exist that are usually associated with Mac user groups and have a single telephone access number. You can find these local bulletin boards by contacting a user group, or by consulting one of the free national computer newspapers, such as *Computer Currents* or *Micro Times*.

While you sort through all this information from your Mac, mainframe computers work at processing requests from callers. Smaller bulletin boards use a single computer that can handle a few dozen callers, and the big on-line services employ networks of mainframes that can handle thousands of callers around the world. These services provide local telephone access numbers in the major metropolitan areas, so you can have an on-line discussion with someone in Australia while paying a local telephone rate.

Don't expect much in the way of an interface. Although some services claim to be the electronic equivalent of magazines, none has come close to the random access nature of the printed page. Graphics, in those few services

that support them, are primitive by Mac standards, due to the speed limitations of modem transmission and the fact that PCs without graphical interfaces are also accessing the same services.

Choosing an On-Line Service

On-line services vary in cost, services offered, and number of local access phone numbers around the country. Stock and commodities quotes are commonly available, with figures that are as recent as 15 minutes old. Many services let you do your banking, shopping, and travel reservations through your modem as well. Some services even offer on-line technical support directly from hardware and software vendors.

Most services have a one-time hook-up fee to access the basic service, plus an hourly rate that varies with the time of day. You may also have to pay a download charge for certain items or consulting services. There are often additional charges to join special interest areas, such as those that focus on the Mac. Access to research libraries may also result in a surcharge.

Your costs will also vary depending on the speed of your transmission—slower speeds will cost you more in on-line time. Most services offer 2,400 bps transmission, but not all offer 9,600 bps. Higher transmission speeds often have higher hourly rates, but you'll still save money in the long run with the faster transmissions.

The following sections present an overview of some of the bigger on-line services.

CompuServe Information Service (CIS)

CompuServe Information Service (CIS), with over 900,000 members and 300 special interest forums, is one of the biggest on-line services in the world. Two hundred of these forums offer hardware and software technical support from some 300 companies. About 90 percent of the United States can access CompuServe via local telephone numbers.

Some of the services offered include electronic mail and conferencing; news wire services such as Associated Press and the Washington Post; airline, hotel, and car reservation services, as well as a variety of financial and brokerage services. Libraries include IQuest, a research library with over 850 databases from business and industry, and the Computer Library, which contains Computer Database Plus, a database for a variety of computer publications.

Macintosh users will find a number of special-interest sections on CompuServe. MAUG, the forum of the Micronetworked Apple Users' Group, features an extensive library of Macintosh utilities. *MacUser* and *MacWEEK* magazines offer ZiffNet/Mac, or Zmac for short. ZMac's Download and Tech Support forum includes utilities specially commissioned by ZMac to make Mac computing easier. The MacWEEK forum is a good place to find

late-breaking Macintosh news; the MacUser forum is useful for asking questions or giving feedback to the editors of *MacUser*. ZMac is part of the larger ZiffNet section, which covers other Ziff-Davis magazines that are PC-based, including *PC Magazine* and *PC Week*.

CompuServe Interfaces If you connect to CompuServe with a general telecommunications package such as MicroPhone II or Smartcom II, you'll get a terminal emulator-like interface. To navigate CompuServe, you make a selection from a series of numbered lists representing services, areas, and libraries, messages, and everything else CompuServe offers. You can also navigate CompuServe using keyboard commands. It's not bad for a command-line interface, but for a more convenient Mac look and feel, you can get a front-end application called *CompuServe Information Manager*, or CIM (see Figure 3.8). CompuServe charges extra for it, but gives you an equivalent amount of free connect time.

Figure 3.8

CIM puts a friendly face on CompuServe.

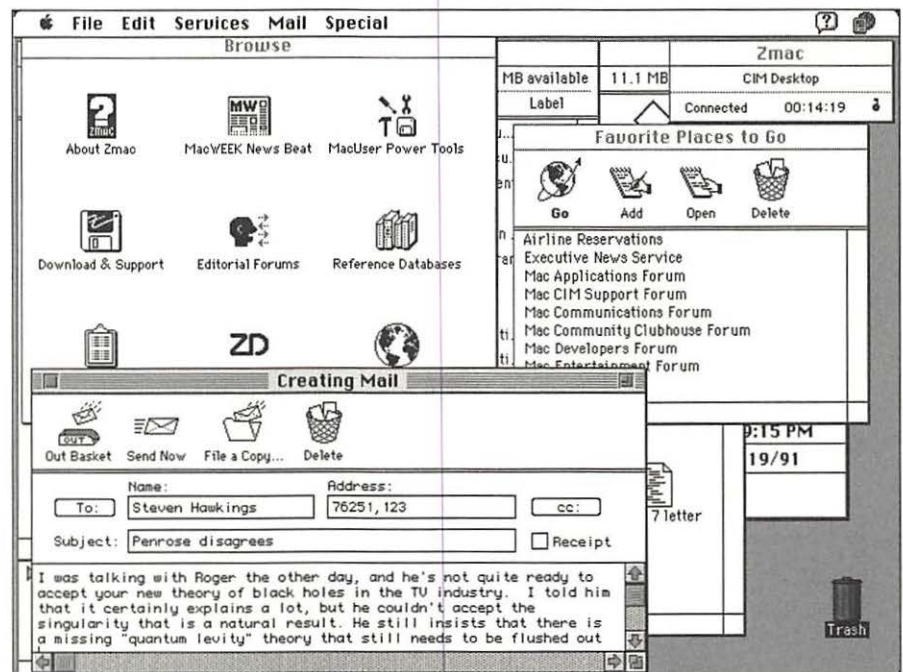

A third-party commercial utility called Navigator is another good front end to CompuServe. It can save you quite a bit of money in connect time by automating your on-line sessions; it will quickly find and download your

forum and mail messages so you can read them off-line. Similarly, Navigator will upload messages created off-line.

America Online

America Online is cheaper and smaller than CompuServe but offers some of the same types of services such as stock quotes, portfolio management, world news and current events, and travel reservations. Also featured is service and support for over 70 Mac software and hardware vendors.

America Online's big feature, however, is its Mac interface, which is elegantly implemented, intuitive, and in color (see Figure 3.9). America Online comes with its own front-end application which dials and connects the user to the service and offers icon-based navigation. For ease of use, it is superior to CompuServe's CIM, and is probably the best interface on any general-purpose on-line service. (America Online also has a front-end application for PCs.)

Figure 3.9

America Online's interface makes it easy to navigate through the service.

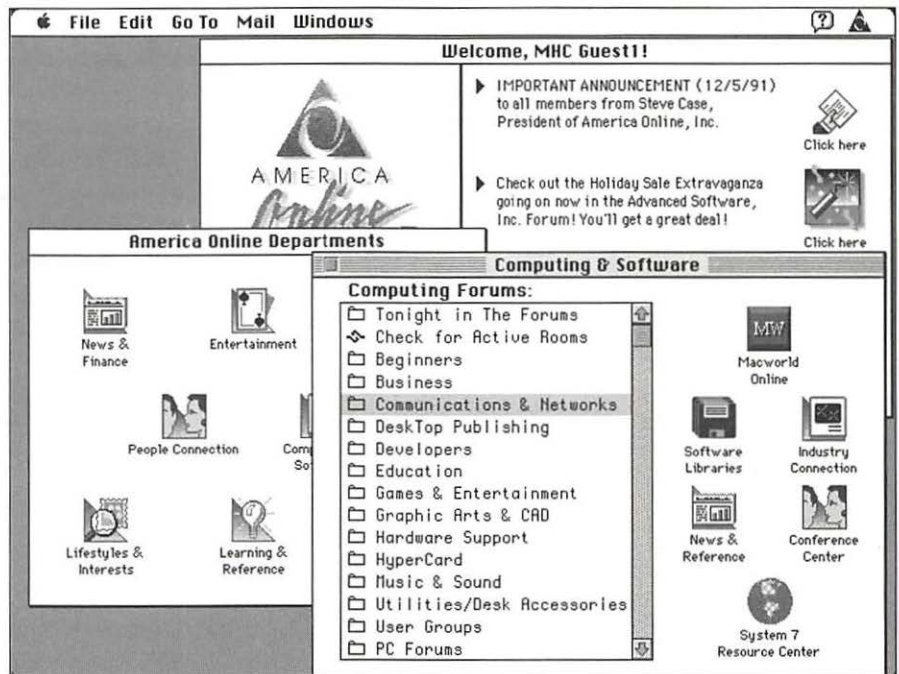

Mac users will also like America Online's advanced live conferencing system; it's quick, easy to use, and reliable, and almost never garbles messages. In addition to libraries containing over 25,000 Mac shareware and freeware programs and good Macintosh forums, America Online has a special interest

section called Macworld Online. Similar in concept to CompuServe's ZiffNet/Mac, Macworld Online offers Macintosh product information, additional libraries of utilities, and a forum that allows users to contact *MacWorld* editors for help with purchasing and technical issues.

AppleLink

Apple Computer's rather specialized international service is not for everyone, but does provide some unique services that aren't found anywhere else. You won't find stock quotations or airline reservation systems, but AppleLink does give you access to the latest pricing and technical information on the entire Apple Macintosh product line, as well as on discontinued Macintosh models and old versions of Apple software. You will also find Apple press releases and news items. Since AppleLink started as a private service for Apple employees, developers, and press members, it is the best electronic method for contacting hardware and software developers. There are bulletin boards on application areas, such as desktop publishing, and tech support forums run by developers.

AppleLink's interface is a model for Mac on-line computing, and looks much like the Mac's Finder (see Figure 3.10). Access to the service is through the AppleLink application. The application and the on-line service are tightly integrated; it's hard to tell where the line between them falls.

AppleLink includes the most sophisticated electronic mail system to be found on any on-line service. Multiple files can be attached to a mail message by clicking a few buttons. When files are selected for sending, the AppleLink application automatically compresses them. You also don't need to bother with file transfer protocols or formats—that's all handled in the background.

MCI

MCI is the largest electronic mail service available, with over a million subscribers. MCI requires a standard telecommunications program, such as Microphone II, to connect, and MCI uses a rather blunt command-line interface. Its minimal on-line help feature describes the various commands.

MCI mail can interface with other forms of mail; a message can be delivered in paper form throughout the country. You can also specify messages to be sent as faxes, but Macintosh users will find a fax modem easier and more convenient. You can't, however, attach a file to a message.

MCI also offers the Dow Jones News/Retrieval service, with which you can get stock quotes and news from the Dow Jones News Service, *Wall Street Journal*, and *Barron's*. However, you won't find much in the way of Mac-related information on MCI.

Figure 3.10

AppleLink provides the latest in Apple product information.

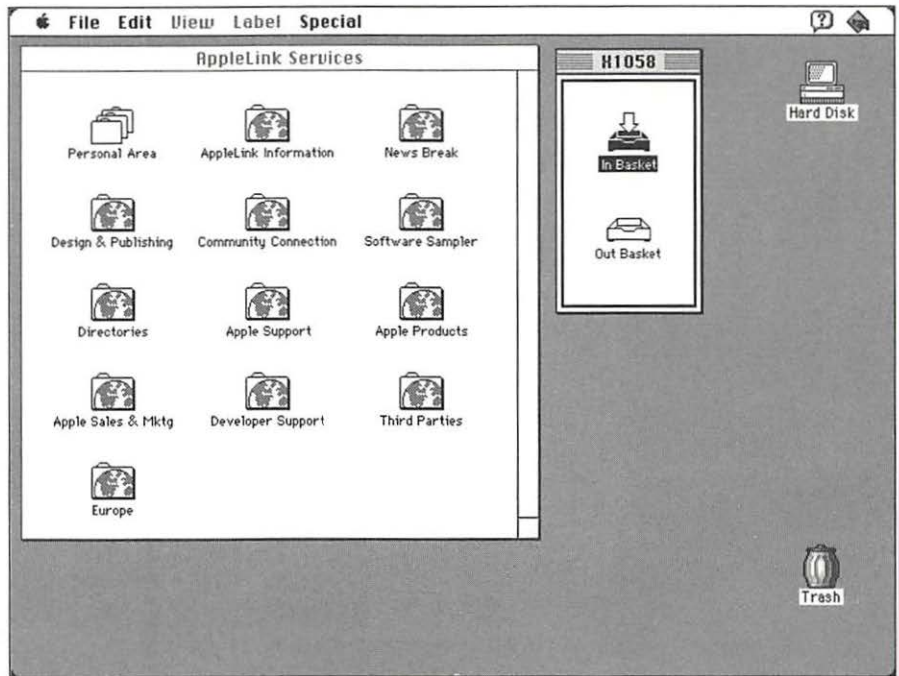

Prodigy

Prodigy may be the next largest service after CompuServe, but it is not a very useful service for Mac users. Although it offers some of the same types of services as CompuServe, it carries very little Macintosh-specific information and offers no file-transfer abilities.

Prodigy has a unique approach to interface design that some DOS users like, but most Mac users loathe. It is a graphical interface, but instead of using a front-end program on your Mac, it sends the entire graphics screen over the phone line to your Mac. This makes Prodigy the slowest on-line service you'll ever see. In addition, the quality of the text and graphics is poor.

In addition, Prodigy takes over your entire Mac screen, obscuring even the menu bar and preventing you from switching to another application. It doesn't help if you have a large monitor because Prodigy will enlarge the text to fit any size screen.

On the plus side, Prodigy is fairly easy to navigate through. On-line time is completely free—Prodigy supports itself by running on-line commercials. Prodigy offers stock quotes, libraries of text files, and more shopping than you could imagine.

GEnie

GEnie, a less expensive alternative to CompuServe, is run by General Electric. Although you might expect forums on refrigerators and ovens, GENIE offers information on PCs and Macs, as well as news, weather, sports, financial information, and an American Airlines travel service. Other services include *Grolier's Electronic Encyclopedia*, bulletin boards, and live conferencing.

Delphi

Delphi is a service that offers many of the business, financial, and consumer services already mentioned (such as stock quotes and news), and the Macintosh ICONtact special interest group. However, Delphi does claim one unique service: It offers you the opportunity to create your own forum. For a fee, you can set up a custom forum on any topic you like. You can allow access to anyone, or limit access to anyone you like.

Delphi has an incentive to create interesting and lively forums. If your forum succeeds in creating a certain level of popularity, Delphi will waive your monthly fee. If the forum really takes off, Delphi will actually pay you as a systems operator (sysop).

Looking for Goodies

You can find some real freeware and shareware gems by poking around in the libraries, but because some of the on-line services are so big, searching for what you need can be both time-consuming and costly. Each special interest area may be divided into many forums, each of which may contain several libraries of files subdivided by category.

To keep your on-line costs down, it's best to do some research off-line before you start. First, decide on the areas of the service that are most likely to apply to your needs. You can usually get a list of special interest sections from the service when you sign up. You can use this list to figure out which categories of files you'll search when you're on-line.

You can usually look through a list of files when you enter a forum, but this is time-consuming. Using the search feature to help you locate files is a more efficient alternative. You can enter key words like *word processing* or *network* to narrow down the list of available utilities or articles. Once again, you'll save time if you know the keywords you'll use before you log on.

If you know the exact name of the utility you want, you may not find it in a search for file names because most files are stored in compressed (and therefore renamed) format. You'll have better luck using the name of the utility in a keyword search. A good strategy is to do the search, get the resulting list, and read it off-line. Then go back and download the files in which you're interested.

Since you pay for an on-line service by the minute or hour, the actual cost of downloading files depends on your on-line habits. It may not be economical to download large files if you have a slow modem. For instance, although free copies of System 7 are available on many libraries, you may end up paying less for it at a retail store.

Chatting on the Forums

The cost of an on-line service can be worthwhile even if you access nothing else but the forums, also called electronic bulletin boards. This is where you can communicate with experts in all areas of study, from Macs to investing to books. You can get free advice on a technical problem or on what type of hard disk to buy. Posting a question in the appropriate forum usually generates multiple responses—people like to show off how much they know in public, so don't be embarrassed to ask a seemingly dumb question.

Forums generally group messages into subject categories, which contain *threads*. A thread starts when someone posts a message and people respond. Threads can be hundreds of messages long, and can consist of lively discussions filled with valuable information. Don't be afraid to join a thread in the middle of a discussion and ask for someone to fill you in. On the other hand, threads can also be filled with inside jokes that only two or three people understand. In my experience as a sysop on ZiffNet/Mac, I've discovered that threads share a similar life cycle. The best ones start with an interesting question or comment, which is quickly responded to by a number of knowledgeable people. The discussion becomes animated and sometimes controversial, branching out into broader issues as well as some specific related issues. At the end of a thread's life, it usually deteriorates to chitchat between a group of regulars.

Writing a conversation on-line may seem natural enough, but there are some differences in etiquette from spoken conversation. For one, make sure your Caps Lock key is off. A paragraph in all caps is difficult to read and will annoy other forum browsers. Also, keep your messages short—an on-line forum is not the place to write the great American novel. It takes time for people to download and read these messages. Veteran browsers, people who can answer your questions, often just skip over long messages. And, most important, always remember that you are in a public forum: You don't want to say anything that would offend anyone or any group.

■ Looking Ahead

Whether hacker or headmaster, the telecommunications products and procedures presented in this chapter can help you be more productive at your

desktop. But what about when you're not at your desk? When you're out on the road with a laptop computer, telecomputing becomes your primary link with the rest of the digital world. The technology is basically the same as telecomputing in your office, but your resources are limited and the environment is less friendly to connectivity. There are additional technologies and techniques that can make laptop connectivity as easy as it is in your office—well, almost. I'll explore these and other issues in the next chapter.

- *Built In: AppleTalk Remote Access*
 - *The Well-Connected Telecommuter*
 - *Using the PowerBook As Your Desktop Mac*
 - *DOS for Mac Users*
-

C H A P T E R

4

The Traveling Mac

LAPTOP COMPUTERS, ONCE A LUXURY RESERVED FOR TOP executives, have now become a common sight at conferences and in hotel lobbies and airplanes. It's also become common at computer trade shows to see crowds clamoring around the booths of laptop vendors, whose sales are growing faster than those of desktop PC vendors. Although Macintosh laptops were a late entry into the field, support for Apple's PowerBook and Outbound's Notebook is just as strong as it is for DOS laptops. To many, Apple's PowerBook has become the Mazda Miata of Macs—compact, sleek, and sporty. Still, it's hard to remember when something this alluring has been as practical a tool. Now that your Mac desktop has been freed from the boundaries of your desk top, you

can take it with you—your Mac, your work, and your connectivity.

An argument can be made that we're better off without laptops—a business trip is an opportunity to escape the office grind, and we shouldn't have to take our equipment with us. But laptop computers enable us to squeeze productive hours out of a busy schedule, and laptop connectivity gives us the power of being as well-connected on the road as we are at our desks. Laptop connectivity allows us to take important trips that pressing matters at the office might have otherwise prevented.

Since Mac-compatible laptops from Apple and Outbound work the same way as desktop Macs, they can run all the same word processing, spreadsheet, and database software you use at the office. With the right connectivity hardware and software, you can also access the same resources that you have available at your desk and deliver results before you get back to the office. All you'll need is a modem, a few small pieces of hardware, and some connectivity software to enormously improve your productivity on the road.

Built In: AppleTalk Remote Access

Your Mac's system software already comes with all the pieces necessary for direct connection to a network, but the Apple PowerBooks also come with software that lets you connect to a network over a modem. AppleTalk Remote Access is the single most useful piece of connectivity software you can take with you on the road. It comes free with every Apple PowerBook, and you can buy it separately for your Outbound laptop or home Mac. Together with a modem, AppleTalk Remote Access offers complete access to your office, including the hard drives on your office Mac as well as any shared volume or device on your office network. You can mount your office Mac's hard disk on your laptop's desktop, print a file on your boss's laser printer, or read your office electronic mail.

Making a Connection

AppleTalk Remote Access is easier to use than most telecommunications programs. You first establish a connection with a remote Mac, then log onto the network services you want. To make a connection, you type in the telephone number of a modem connected to a Mac at your office that's running AppleTalk Remote Access, type in a password, and click Connect (see Figure 4.1). The software will dial the number and establish a connection. If you frequently call a particular Mac, you can create a file on your laptop that will remember the phone number and password; double-clicking on this file will start the log-in procedure. Both Macs must be running System 7 and AppleTalk Remote Access.

Figure 4.1

With AppleTalk Remote Access, connecting your laptop to your office Mac and network is a mouse click away.

My Office Mac

Connect as: Guest
 Registered User

Name: John Rizzo

Password: *****

Phone: 5551234

Save my password

Remind me of my connection every: 30 minutes

Connect

Once a connection is made, you can select network services from your laptop's Chooser. To pick an office laser printer, you click the Chooser's LaserWriter icon and select one printer from the list. Your office Mac's hard disks, as well as file servers and folders shared with System 7's File Sharing feature, are all accessible through the Chooser's AppleShare icon.

Logging On

You can log onto your office electronic mail system, such as Microsoft Mail or QuickMail, using the standard desk accessory that comes with the mail software. System 7 will let you combine the AppleShare Remote Access log-in and the Chooser log-in procedures. From your laptop, select a remote hard disk or file server that you've mounted on your desktop with AppleTalk Remote Access. Make an alias of the mounted disk using the Finder's Make Alias command in the File menu. The next time you need to connect to the network via a modem, double-click on the alias: It will automatically activate AppleTalk Remote Access, dial the remote Mac, establish a network connection, and mount the remote disk on your laptop's desktop.

Using AppleTalk Remote Access

Once logged on, the office network appears exactly as if you were there except for one aspect: speed. The relatively slow speeds of modems impose some limitations on network access with AppleTalk Remote Access. Copying files from your laptop to your office Mac is a good way to make sure your work gets back to your office, but even at 9,600 bits per second (bps), it's best to avoid transferring files larger than a megabyte. As is good practice in all telecomputing, you should compress a file with an archiving utility such as StuffIt before you send it. In addition to any compressing you may do, AppleTalk Remote Access uses its own v.42bis data compression, regardless of what type of modem you use. If you already have a v.42bis modem, AppleTalk

Remote Access will sense this and prevent the modem from using v.42bis compression a second time.

Whatever your speed, it is not a good idea to open applications remotely unless you have plenty of time and battery life to spare. Running a remote application over AppleTalk Remote Access requires frequent transfers of information over the phone lines between the remote application and your Mac's RAM and CPU. AppleTalk Remote Access gives you a warning if you double-click on an application at the other end of the modem; it's best to heed the warning and cancel.

AppleTalk Remote Access has several security features to keep out electronic intruders (see Figure 4.2). You can configure the Mac at your office to hang up and call your laptop back when you first log in. This prevents anyone from logging in who is not calling from the number you've specified beforehand. Another advantage of using the call-back feature is that the telephone call is billed to the office, since your office Mac is calling you.

Figure 4.2

AppleTalk Remote Access enables you to set your office Mac to hang up and immediately call back anyone trying to make a connection. You can also assign passwords and limit access to other users and groups.

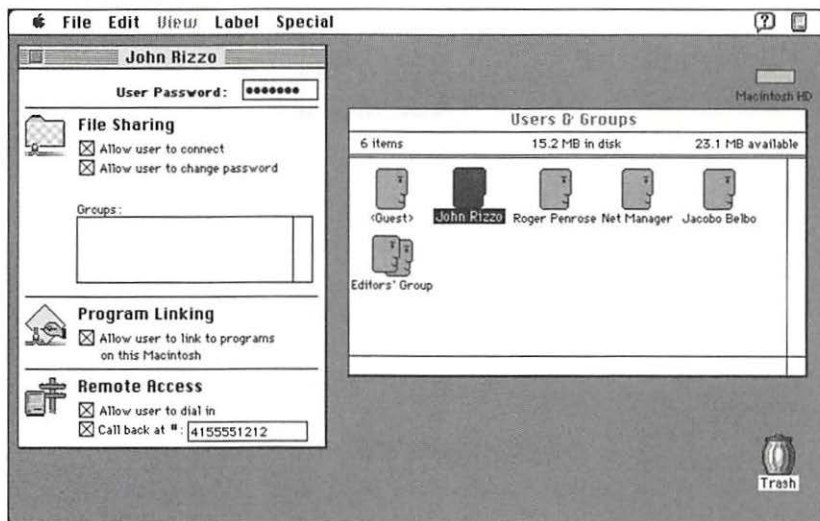

AppleTalk Remote Access also lets you assign log-in privileges to individual users and groups the way System 7's File Sharing does (as I'll discuss in Chapter 7). A potential problem with this scheme is that access to the office network can be set up by any of your coworkers who uses AppleTalk Remote Access. If users aren't careful about limiting access when setting up AppleTalk Remote Access, they can inadvertently open the entire network to anyone who knows their modem's telephone number. It's therefore important to disable "Guest" access.

One fix for this problem is to advise users not to call into their desktop Mac, but to call into a centralized remote access server, such as Shiva's LanRover, a piece of hardware about the size of a Hayes modem. LanRover shifts the responsibility of allowing network access from every AppleTalk Remote Access user to a single network administrator. From a single copy of LanRover software running a Mac, a network manager can set up user lists and network access privileges associated with multiple LanRovers. If a network administrator wanted to set up everyone's AppleTalk Remote Access without LanRover, adding a user to 50 Macs running AppleTalk Remote Access would require an administrator to repeat the procedure 50 times. With LanRover, the administrator would add a new user to one list, and select 50 Macs from a window.

■ The Well-Connected Telecommuter

Whether you're attending a meeting 2,000 miles from your office or working at home, your ability to connect to other computers depends on what you choose to bring with you. What you carry is constrained by weight, RAM, and battery power, all of which must be conserved.

In addition to your laptop, you may need to take one or more peripherals—external hardware components that add functionality to your Mac, but which also add weight and use battery power. The software you load on your laptop's hard disk should also be carefully selected to ration valuable RAM. There are also odds and ends—low tech gadgets—that can help connectivity.

It's best to decide on what you need before you take the first trip with your laptop. Put together a travel connectivity kit that contains your laptop, any peripherals you require, the software loaded and configured on your hard disk, and any gadgets you may need. It's easier to remember to bring one kit than an assortment of tools scattered about your desk. We'll take a look at what specifically should be in this kit, starting with peripherals.

PowerBook Peripherals

It's always a good idea to travel with a floppy drive and spare disks; if your laptop doesn't have a built-in floppy drive, you should always bring an external drive with you. You never know when you'll need to give a file to someone or copy one from a hard disk. Floppies are also important for making frequent backups of your work, a necessary precaution since laptops (and their hard disks) tend to get the shake-and-bake treatment during a road trip. Apple's external floppy drive for the PowerBooks is lightweight and doesn't take up much space. Remember, a floppy disk offers connectivity to

PCs too, since the floppy drives in Apple's PowerBooks and Outbound's Notebooks can read and format 3 1/2-inch disks in DOS and OS/2 formats.

If you don't have a floppy drive, carry a serial cable and a copy of a file transfer program such as MacLink Plus/PC so you can trade files with a Mac or PC. This is less convenient and slower than using a floppy drive. Some laptops, such as the PowerBook 100 and the Outbound Notebook Series 2000, offer a faster (but Mac-only) cable-connection option called *SCSI disk mode* for PowerBooks and *SCSI emulation* for the Outbound models. This feature enables you to connect a laptop directly to another Mac via a SCSI port, so that the laptop hard disk drive appears as a mounted drive on the other Mac's desktop.

Figure 4.3 shows such a setup, although one or more terminating resistors may be required, depending on the Mac model. (Terminating resistors are used to stabilize voltage, usually at the end of SCSI chains.) Files can be transferred from one machine to the other with a click-and-drag. Although a serial connection offers a maximum data transfer rate of 57,600 bits per second, SCSI emulation can transfer data somewhere between 1 and 4 million bytes per second, depending on the Mac model.

Another option for transferring files with a Mac is to use LocalTalk and System 7's built-in File Sharing, described in detail in Chapter 7. All you need to carry is an ordinary telephone wire with an RJ-11 connector at each end, and a LocalTalk connector for each Mac. Farallon's compact PhoneNet Star Connectors are ideal for traveling.

If you plan to print out your work, you might also consider carrying a printer with you instead of assuming you'll find one at your destination. Inkjet printers are the ideal portable printer; they're inexpensive, small in size, and weigh about as much as a laptop Mac. Inkjet printers produce near-laser quality text and graphics, and are also quiet enough to use late at night.

Apple's StyleWriter is one of the smallest and lightest inkjet printers, and produces excellent quality printouts. Make sure you use StyleWriter printer driver version 7.2 or later, which enables the StyleWriter to print up to three times faster than the original version. (You can get a free upgrade from a dealer or an on-line service.) Hewlett-Packard's DeskWriter is somewhat bigger and doesn't have quite the print quality of the StyleWriter, but is faster. A color version, the DeskWriter C, is also light enough to carry.

Modems for the Road

For many travelers, the most indispensable peripheral to bring on the road is a modem. Some of the same issues discussed in Chapter 3 should be considered when purchasing a modem for use with a laptop, but you may need some additional features when traveling. For instance, the metal box in which some desktop modems are encased can be a burden to carry, as are

Figure 4.3

SCSI emulation enables a desktop Mac to see a laptop as an ordinary disk drive.

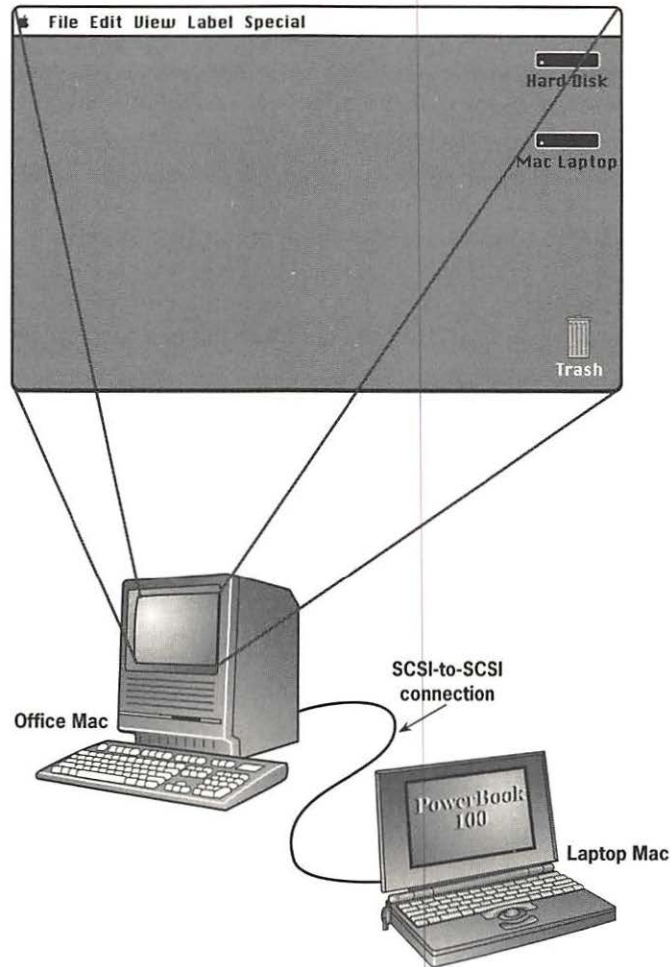

the power supply “bricks.” More preferable is a small plastic modem that doesn’t require a power supply but instead takes its power from the Mac’s serial port. These modems, such as Outbound’s wallet-sized Pocket Port and Mass Micro’s MASS 24/96, weigh well under a pound.

The most convenient portable modems are not peripherals at all, but fit inside the laptop. Internal modems usually consist of a single tiny circuit board, and are powered by the Mac. The most persuasive argument for an internal modem is that you can’t forget to bring it with you once it’s installed in the laptop.

Many laptop modems—portable or internal—also support sending faxes, a feature discussed in the last chapter. A fax modem that is capable of receiving faxes is not as practical with a laptop as it is with a desktop Mac if your travel takes you to a variety of places; you'd have to give everyone you know a new phone number every time you changed locations.

If you plan to regularly exchange files or use office electronic mail with AppleTalk Remote Access, 9,600 bps is the minimum speed you should consider for a laptop modem. Global Village Communication was one of the first to offer a 9,600 bps modem for the PowerBook. The PowerPort/v.32 is mostly internal, with a small external telephone interface module that attaches at the back. The speed of the PowerPort is further enhanced with v.42bis and MNP 5 data compression and with fax send and receive functions.

Cellular Modems Starting in 1992, laptop users were offered a brand new option, the cellular modem. It's tempting to write off the cellular modem as yet another yuppie toy—a way to check stock quotes on line while driving to work—but this new technology does offer an additional degree of freedom. You don't always have access to a telephone line if you are, for example, in an airport, on a commuter train, or at a restaurant. Salespersons, insurance adjusters, technicians, and others who work out in the field can use cellular modems to access data without the need to worry about reimbursing anyone for a long distance call.

The *cell* in *cellular* refers to a geographic area a few miles wide containing a small radio transceiver to broadcast telephone signals over radio waves. Rather than use a big transmitter to broadcast signals over hundreds of miles, as with a powerful AM radio station, cellular signals are broadcast through a network of these cells that connects to land lines. The cells are linked together so that traveling from one cell to another does not interrupt a telephone conversation.

Cellular modems work over the same cellular networks that are set up for cellular telephones, so you'll need a cellular telephone account. These are quite a bit more expensive than ordinary telephone service, for both the monthly service charge and the per-minute rate. You may also need a cellular phone. Cellular modems can run the MNP 10 protocol described in Chapter 3 for computer-to-computer communications, but most need cellular telephones to make contact with the cellular network.

You can plug a cellular modem directly into a cellular phone if your telephone has an RJ-11 jack. If the phone has what is called a "smart" RJ-11 jack, you can let your modem dial the number through your computer; if not, you'll have to dial manually from the handset.

If your phone doesn't have an RJ-11 jack at all, you'll have to connect the phone to an interface box called a *tip and ring* or *tellular* box. (See Figure 4.4.)

This box fools the modem into thinking it is connected to a land line by providing a dial tone and generating a ring. A general-purpose tellular box, such as the Data Cell from Zirco, will work with almost any cellular phone, any computer, and even stand-alone fax machines.

Figure 4.4

A typical cellular modem setup requires an interface box to connect to a cellular phone.

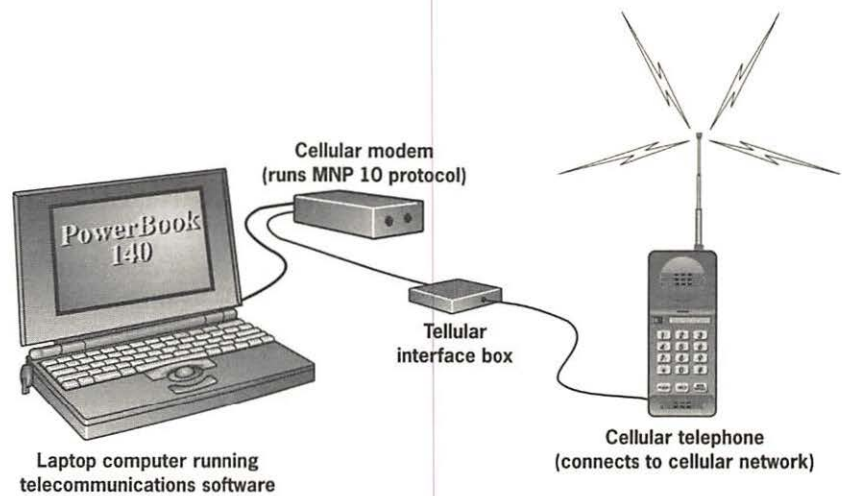

As cellular modem technology matures, we should see more stand-alone cellular phone/modem combinations, including those that fit inside laptops. The first cellular modem integrated with a telephone was the Cellular Data Link from Mitsubishi and Microcom, which was introduced in early 1992. It can get its power from an AC power supply, from a car's cigarette lighter, or from a battery that lasts about three hours. Internal cellular modems for laptops are the most convenient, but will shorten a laptop's battery life considerably. These are currently the scarcest type of cellular modem. None of the Mac laptops can be purchased with built-in cellular modems at this time, although several PC laptop manufacturers offer cellular modems on their higher-end models.

Software for the Road

Although the PowerBook already comes with powerful connectivity software for the Mac on the go, there are additional connectivity and productivity applications and utilities that greatly enhance working with a laptop. But, with hard disk space and RAM at a premium, you just don't have the room to throw every power user's application on your laptop's hard disk. You must instead choose your laptop software carefully.

Connectivity Software

In addition to AppleTalk Remote Access, your laptop's hard disk should contain a general-purpose telecommunications program, such as those described in the last chapter. A telecommunications package is useful for cases when you can't use AppleTalk Remote Access, such as for transferring files to or from PCs or for logging onto a mainframe in terminal emulator mode.

A telecommunications application also enables you to access electronic mail offered by on-line services. Electronic mail is an effective way for you to keep in contact with your associates while you're moving about, since you can read and send messages after business hours, when it would be impossible to get in touch with anyone by phone. Although you can also access your office electronic mail system using AppleTalk Remote Access, electronic mail offered by on-line services is available to a wider audience than just your office staff.

Also, you may want to carry a copy of a DOS disk-mounting utility, such as those described in Chapter 2. These utilities take up very little disk or RAM space, and ensure that any DOS disks you insert will be mounted on your laptop's desktop. Outbound laptops already come with a DOS disk-mounting utility, as does Argosy's Software Bridge transfer/translation software.

Screen-Sharing Software Screen-sharing software, mentioned in Chapter 2 as a method of running PC applications from your Mac, is a class of connectivity software that can be useful when you travel. Whereas AppleTalk Remote Access connects you to a Mac's hard disk and a network over a modem, screen-sharing programs such as Farallon's Timbuktu and Microcom's Carbon Copy Mac let you control a Mac from another Mac on a network, or from a Mac connected by a modem. The screen of the Mac you are controlling appears in a window on your Mac (see Figure 4.5). Screen-sharing software can also give you remote access to a network, but this access is indirect, through the Mac you are controlling.

The differences between AppleTalk Remote Access and screen-sharing programs are subtle but important enough to make it worthwhile to install both types of programs on your laptop. The main difference is that AppleTalk Remote Access connects a Mac to an AppleTalk network, giving you direct access to network services; Timbuktu and Carbon Copy Mac use a network connection to control a Mac. Carbon Copy Mac and Timbuktu Remote can also control a Mac over a telephone connection, but this is not a network connection. Certain tasks are faster with AppleTalk Remote Access, and others are better suited to a screen-sharing program. With still other tasks, the best solution is to run both a screen-sharing program and AppleTalk Remote Access at the same time.

Figure 4.5

Screen-sharing software such as Farallon's Timbuktu lets you control a remote Mac from a window on your Mac.

Application running on remote Mac

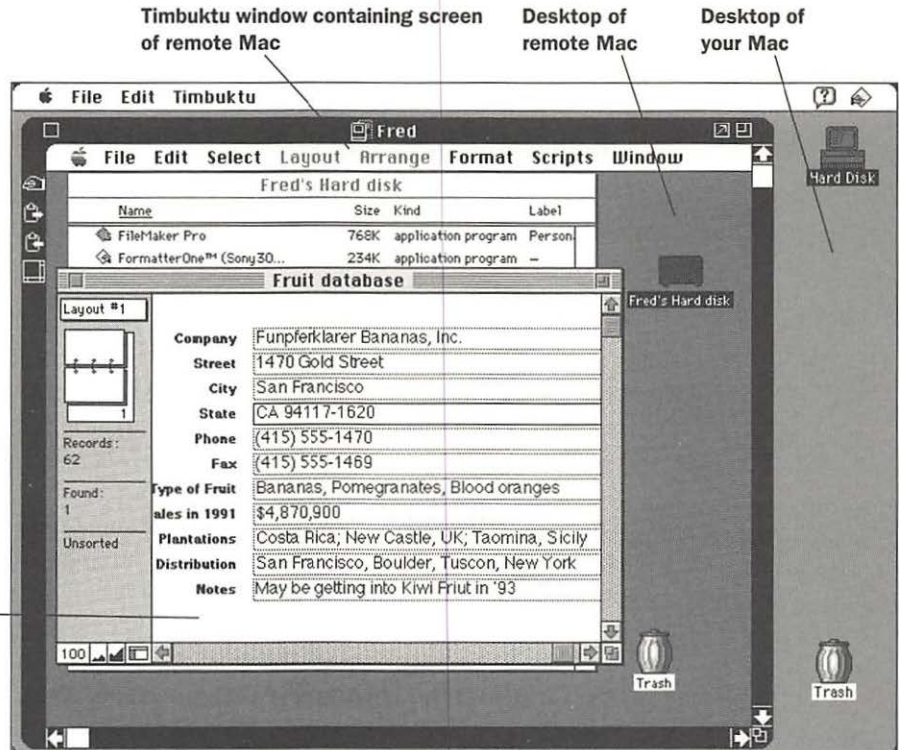

AppleTalk Remote Access is the faster method of accessing a Mac's hard disks. It's also the best way to access file servers and printers, since screen sharers don't access these network services directly. Also, AppleTalk Remote Access is easier to use than screen-sharing software. However, screen sharers offer the big benefit of enabling you to run applications on the office Mac from your laptop; this is not recommended with AppleTalk Remote Access. You can do this with screen sharers because these programs keep all the processing confined to the Mac you are dialing into: The screen information is all that is getting transmitted over the modem to your Mac. With AppleTalk Remote Access, processing would be done on your laptop Mac, with lots of instructions going back and forth over the modem between the laptop Mac's CPU and the application on the Mac at the other end of the connection. For this reason, screen-sharing programs are better than AppleTalk Remote Access for running databases on remote Macs.

When you run the screen-sharing software and AppleTalk Remote Access at the same time, AppleTalk Remote Access is used to establish the network connection, which the screen sharer uses to control a Mac on the

other end. This type of setup gives you both the benefits of controlling another Mac and the access to network services provided by AppleTalk Remote Access. In addition, using the screen-sharing software's file-transfer feature over AppleTalk Remote Access is faster than using the Finder to click and drag files between your hard disk and a mounted shared volume.

Productivity Software

Since laptop hard disks, typically, are small, it's not a good idea to copy an entire application installation disk onto your laptop. You can do without the sample and tutorial files, for instance, and you certainly don't need more than one copy of TeachText, the text reader for Read Me files that comes on many application disks.

Most users don't have as much RAM in their laptops as they do in their desktop Macs. Not only is PowerBook RAM expensive, but you'll use battery power at a faster rate if you load your laptop to its maximum limit. If you use your laptop mainly for word processing, you should have no problem continuing to use your favorite application with a 2-to-4Mb laptop. If you need to use several applications at the same time, however, you might consider loading your laptop with smaller, simpler programs. Using different programs on your desk and laptop Macs is usually not a problem, since most programs can save files in a format that other similar programs can read.

The easiest way to cram the most applications into a limited RAM space is to use one of the integrated-works programs. These programs are the Swiss Army knives of software, offering word processing, spreadsheet, drawing, database, and sometimes other functions, all in one application. Works programs take up far less memory and hard-disk space than all those applications would take up separately. Microsoft Works was the original, and for a long time, the only works package, but it now has competition from BeagleWorks and Symantec's GreatWorks. ClarisWorks is one of the best works programs, with high functionality and tight integration between the modules.

If you don't need the number of programs offered in a works package, you might consider scaling down from your power user's application to a simpler program. For instance, if you don't need all of Microsoft Word's high-end features, T/Maker's WriteNow, a smaller word processor that takes up less than 300k of RAM, should be sufficient for most of your needs. Paragon has a laptop version of its Nisus word processor called Nisus Compact. In addition to fitting into 400k of RAM, Nisus Compact adds a built-in battery indicator and a thick I-beam to help you locate the cursor, which can sometimes be difficult on a laptop display. WordPerfect also has a scaled-down version of its word processor called LetterPerfect. For a spreadsheet, Claris Resolve is a fine alternative to Microsoft Excel, since Excel has many features you can do without on most road trips.

Databases can take up a lot of disk space, but you may not need to bring the entire data set with you: Create a copy of the database application for your laptop, and import the portion of the records that you think may be pertinent. Or just bring the application and leave the data on your hard disk or file server at the office and access it with a modem and AppleTalk Remote Access or screen-sharing software such as Timbuktu. If your data consists of telephone numbers and addresses, you can save some RAM by using a small personal information manager, such as Address Book Plus or Dynodex.

Connections from Concentrix is a personal organizer program that combines a telephone directory database with a personal and group calendar, as well as a note-taking module. Each module is dynamically linked, so you can have your Mac dial a telephone number from the note module, or take notes while recording an appointment. Connections is based on HyperCard, which requires over a megabyte of RAM. However, even with this RAM requirement, Connections is a convenient laptop tool because of its linked modules and its connectivity features for individual or networked Macs.

Finally, try to leave most of your system extension utilities at home. These take up RAM even when you're not using them. Prioritize your utilities to see which ones you can live without. Screen saver utilities (such as After Dark or Pyro) don't make much sense on a laptop, since you shouldn't leave your laptop on for more than 24 hours at a time; this is not long enough to cause the display burn-in that screen savers are supposed to prevent.

What to Carry, What to Leave Behind

A few small, low-tech items can go a long way to make connectivity easier, or in some cases, possible. Developers of hotels and other public buildings don't usually have computer connectivity in mind when they design their rooms, but several ounces of gear can help you make the right connections. For instance, a 6-foot length of telephone cable with standard RJ-11 plugs on each end should be in everyone's traveling kit. The phone cable in your hotel might be only just long enough to reach your bedside table, which is not a particularly convenient place to work.

Some hotels break off the removal tab on the RJ-11 connector to prevent you from unplugging the telephone. This cuts down on phone theft, but prevents you from using a modem. You can get around this by carrying a small flathead screwdriver, $\frac{1}{8}$ -inch wide or smaller. Insert the screwdriver into the slot where the tab usually goes, press on the broken tab stub, and pull out the connector.

NOTE. *Before disassembling any equipment in your hotel room, please check with hotel management. In many hotels, this kind of intervention is prohibited.*

Older telephones or pay phones may not use RJ-11 plugs at all. You can still connect a modem though, if you have a cable with an RJ-11 plug on one end and a pair of alligator clips on the other. Just unscrew the cover cap on the receiver mouthpiece, gently pull out the microphone subassembly, and attach the alligator clips to the exposed metal parts of the red and green wires. Try other wires if different colors are used, or if you're red-green color blind.

You can find a cable with an RJ-11 plug on one end and alligator clips on the other in Farallon's Timbuktu Power Pack. This kit for the well-connected traveler also contains two copies of Timbuktu Remote, a small screwdriver, a Swiss Army knife, and various connectors that might come in handy in an emergency, including a LocalTalk connector and cable for instant network access.

A mouse is a good thing to leave behind. Even devoted mouse fans find it easier to get used to the PowerBook's built-in trackball than to juggle a computer and a mouse on a lap. You can also leave all your manuals at home, even the little portable versions that sometimes come with laptop products. Chances are you won't use them, and they'll end up acting as ballast. Instead, just copy an application's help files to your laptop's hard disk. For checking on a forgotten menu command, Balloon Help (in those applications that have implemented it) is really handy. Balloon Help can also drive you crazy by flashing on and off as you move the cursor, so remember to shut it off after you get your answer.

And finally, what should you carry all this stuff in? Specially designed laptop cases are very attractive, but you may not really need one. Just as a gas will expand to fill a vacuum, your laptop paraphernalia will expand to fill all the pockets of a bag. A briefcase or travel carry bag is the best place for a laptop. If you must have a big carrying case, reserve it for the road trips when you'll require all your peripherals. For around town, use a small slip case, a lightweight canvas covering. This prevents you from lugging around your overnight gear during daytrips.

■ Using the PowerBook as Your Desktop Mac

Mac laptops are no slouches when it comes to processing power—the PowerBook 170, for instance, has a speedy 25 MHz 68030 processor, just like the Mac IIci. Nevertheless, you give up some of the comforts of home when you take a laptop on the road—a big display, color, a keyboard with numeric keypad and function keys, a big external hard disk, and a direct network connection. Fortunately, you can harness the power of your office Mac through the use of the built-in ports that come on most Mac portables (see Figure 4.6), which make it possible to connect a laptop to all of your desktop peripherals.

Figure 4.6

A laptop Mac can function in a complete desktop setup, connected to a standard monitor, hard disk, keyboard, and network.

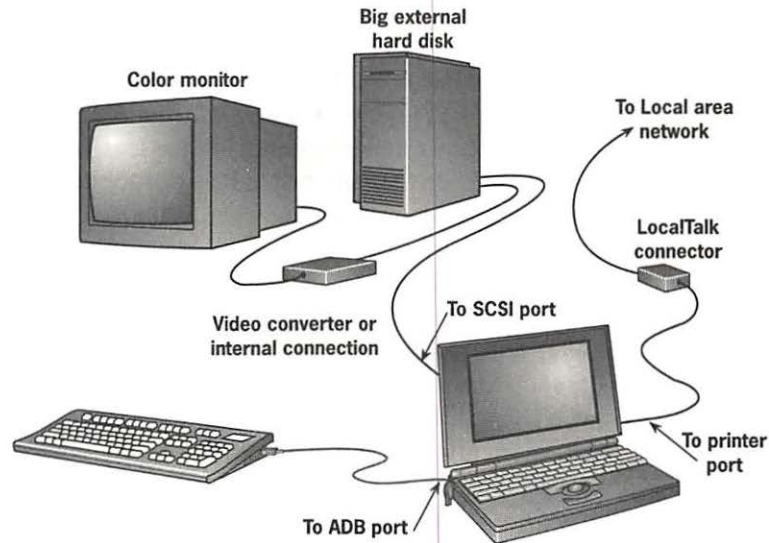

PowerBooks with 68030s display monochrome on their built-in displays, but have the ability to output color video to an external monitor through a third-party add-on converter. (None of the Outbound models supports color, but you can connect large monochrome displays to them.) The converters come in two configurations: as an external device that plugs into the Mac's SCSI port, or as an internal card. Neither is available from Apple.

You can plug a standard keyboard, mouse, and trackball directly into a laptop's ADB (Apple Desktop Bus) port. You can also connect a big external hard disk to a laptop using the SCSI port; however, PowerBooks require the special cable that comes with them, since the Apple laptops have a non-standard SCSI connector. Outbounds use standard 25-pin SCSI connectors and cables.

You can connect directly to a network using the built-in LocalTalk port in the back of your Mac laptop. You can also connect to an Ethernet network using an external serial or SCSI device.

If Your Laptop Is Asleep

Plugging into a network can be a problem if the Mac is in sleep mode, a mode which puts a laptop Mac into a dormant state without shutting it down. (Desktop Macs don't sleep.) Many users don't ever use Shut Down, because waking up from sleep is much quicker than restarting, especially if there are a lot of system extensions to load. The problem occurs when you put a laptop

in sleep mode, physically disconnect it from the network for a period of time, and plug it back in and activate it without first shutting down the Mac. This can cause the Mac to not be recognized on the network, and can cause network problems for other users as well.

When a Mac on an AppleTalk network boots up, it negotiates with the other Macs on the network for a *node number*—a unique numerical name tag for Macs, printers, and other network devices. The Mac asks, for example, “does anyone have number 42?” If any other network device answers yes, the Mac picks another number and tries again. This process is called *dynamic node addressing*.

When you disconnect a laptop from a network to take it with you, there is no longer a Mac to answer yes when another network device asks “does anyone have number 42?”; therefore, another network device can take your number. Meanwhile, your laptop still thinks *it* is number 42 because you haven’t shut it down. When you plug your Mac portable back into the network, there are two network devices with the same node number. The results are unpredictable, but you could get someone else’s electronic mail, prevent users from printing, or create all-around network havoc. To prevent this problem, do a restart before (or after) connecting to the network.

■ DOS for Mac Users

Before the appearance of the Outbound and Apple laptops, many Mac users who needed to take a laptop on the road had no choice but to buy a portable PC running DOS. Using the file-translation capabilities of their software, bi-platform users imported their work into their Macs when they got back to their desks. Some Mac users will still find a PC laptop a useful tool, but there are trade-offs. For those of you willing to accept the drawbacks of DOS, there are certain things you can do to make your DOS laptop more Mac-user-friendly.

First, the benefits of a portable PC. Despite the Mac’s advantages in interface and plug-and-play connections to peripherals, a DOS laptop can be a reasonable alternative to a PowerBook or Outbound if your chief tasks involve mainstream programs such as word processing, spreadsheets, or simple address-book databases. Graphics users should stick with a Mac. The performance of a DOS laptop will probably be better than that of a similarly priced Mac laptop if you don’t run Microsoft Windows; however, the best argument for a PC laptop is selection. There are dozens of DOS laptop models on the market, offering more choices in size, price, performance, displays, and other features than do Mac laptops. Some well-established, high-quality brand names to look for include Texas Instruments, AT&T, and NEC, but many other quality brands exist as well.

Choosing a DOS Laptop

The first thing a Mac user should look for in a DOS laptop is an Intel 80386 processor, roughly equivalent to the 68030 processor used in the PowerBook 140 and 170. Higher clock speeds mean faster machines, but it is meaningless to compare clock speeds on Macs with those on PCs. Clock speed is not a universal measurement, like horsepower in engines, but a relative indication, more like clothing sizes. Laptops using the much slower 80286 are less expensive, but are becoming much rarer due to lack of demand. Some laptops use Intel's fastest PC processor, the 80486, but these machines sell for two or three times the cost of a 386 laptop. For word processing or spreadsheets, a 486 provides more processing power than the average user needs. You might consider a 486 laptop if you frequently run number crunchers that require extra processing power, such as very large spreadsheets, statistics programs, or other specialized software.

Some DOS laptop models offer displays that support graphics in gray scale or color. A high-quality gray-scale display doesn't add much cost to a laptop and can be very effective for presentations. Color displays, on the other hand, are very expensive and are often found on 80486 laptops.

As with Mac laptops, a built-in floppy drive is desirable for backing up, inputting data, and getting files to your desktop Mac. Most DOS laptops have a built-in serial port that you can use to transfer large amounts of data to your desktop Mac using a cable and one of the Mac-to-PC data transfer/translation packages described in Chapter 2. Built-in network ports on DOS laptops are rare.

If your main concern is size and weight, you might consider a calculator-sized palmtop machine, for which there is no Mac equivalent at this time. Palmtops are also small in price; they can often be found for under \$1,000. Palmtops usually have small text-only screens consisting of a few lines, but can run simple word processing, spreadsheet, and address book applications. Some of the smaller palmtops even come with their own serial cable and Mac-to-PC file transfer software. The Hewlett-Packard 95LX, which comes with a tiny QWERTY keyboard and Lotus 1-2-3 built into ROM, has a variety of Mac connection products available through third-party vendors. In addition to transferring data over serial cables, several vendors offer wireless links with Macs. With Motorola's NewsStream infrared port and Ex Machina's Notify! paging system, Mac users can send electronic mail to the 95LX over a distance of a few feet. The Mobidem Portable Wireless Modem from Ericsson GE Mobile Communications lets 95LX users communicate with their Macs over long distances.

Another type of palmtop is the electronic appointment book device, such as the Sharp Wizard, which doesn't use DOS at all, but runs on a basic proprietary operating system. The Wizard's built-in organizational applications

include an appointment book scheduler, telephone contact database, and to-do lists. The Mac-to-PC file transfer programs won't work with the Wizard, but there are several ways to transfer data to a Mac over a serial link. One method is to use the Connections Wizard Link from Concentrix, which is a flexible system with a good interface. The Wizard Link transfers data between the Wizard palmtop and the Connections organizer program running on a Mac. Calendar, address book, and to-do list information can be altered on either the Mac or the Wizard, and transferred to the other machine, while differences in schedule information are automatically reconciled.

Dealing with DOS

Of course, using a DOS laptop means giving up some Mac features. For instance, DOS laptops generally can't connect to all of the peripherals that a desktop computer can—even connecting a full-sized keyboard is simply impossible with most models. DOS notebooks don't have built-in trackballs, though most DOS laptops can accept a mouse or trackball. However, few of the add-on trackballs are as good as the built-in cursor control devices in PowerBooks and Outbounds. Trackballs for PC laptops often clip on the side of the laptop, which is not a particularly comfortable position for working. You usually can't close the lid of the laptop with the trackball attached, so you have to dismantle it every time you finish using the laptop. The lack of a trackball is not a problem if you use a keyboard exclusively, but you'll find it challenging to work without a mouse or trackball if you use Microsoft Windows.

While Windows is tempting for Mac users who want to make their DOS laptops more Mac-like, it's good to keep this in mind: Windows is no Finder. Windows doesn't have the features of the Finder, and is not particularly intuitive for experienced Mac users. I once saw a memo a network manager had written for his office's Mac and Windows users; the memo described how to choose a printer for each type of machine. For the Mac, there was one step: Go to the Chooser and pick the printer. For Windows, there were 22 steps, including typing lines of code.

If you use a laptop primarily for word processing, you may find it easier to avoid Windows and use a word processor that runs under DOS. Typing in a single command at the DOS prompt will bring up the word processor. Microsoft Word for DOS is a good choice for Mac users, as is WordPerfect. I would advise Mac users against WordStar, unless you are prepared to learn another language.

If you are working on a spreadsheet, you'll have a harder time finding a way to avoid Windows. The simplest PC spreadsheet for a Mac user to learn is Excel for Windows, which is almost identical to the Mac version. Unfortunately, there is no version of Excel that runs under straight DOS. Lotus 1-2-3

for DOS is a powerful spreadsheet, but Mac users with little PC experience will run into a steep learning curve.

If you do decide on Windows, look for a DOS laptop that comes with Windows preinstalled. Installation of Windows is not as simple as running Apple's Installer for Mac system software. A technician who worked in his company's computer department once admonished me for telling people in a *MacUser* article that Windows was hard to install. He told me that after doing Windows installations a dozen times or so, he had gotten it down to under 45 minutes. Apple's Installer rarely takes more than ten minutes.

■ Looking Ahead

Since Macintosh connectivity extends beyond the realm of the local area network, many of the connectivity methods discussed in this and previous chapters have nothing to do with networks. The discussions of connectivity methods that do use networks so far have not gone into networks in great detail. This is about to change, as the rest of the chapters in this book will discuss the workings of a network in depth. But regardless of the level of detail or context, any discussion of Macintosh networking always includes one word: AppleTalk.

Just what is AppleTalk, anyway? The answer to this question is not a simple one, so the next three chapters will describe this marvelous piece of engineering that is so crucial to the Mac's easy connectivity. The first piece of information that you should know comes from an early apple adage: AppleTalk is not a cable.

- *Built In: AppleTalk*
 - *Choosing a Data Link Mechanism*
 - *Choosing Media*
 - *Setting Up a Local Area Network*
-

C H A P T E R

5

Network Plumbing

CONSIDER A WELL THAT SUPPLIES YOU WITH ALL THE WATER you need. This resource seems sufficient until you realize that carrying buckets full of water to different parts of the house is a lot of work. You can avoid this labor by installing plumbing to provide services—hot, cold, and warm water delivered to sinks, dishwashers, showers, toilets, garden hoses, washing machines, and bathtubs. Similarly, a network of Macs brings you the convenience of moving data around in the form of file servers, printers, and electronic mail. The pipes and pumps that carry data across a network are the cables and electronic devices that propagate signals. If you've shied away from networking before but are tiring of carrying buckets of data around by hand, it's time to get your feet wet.

Computer networking starts with the local area network (LAN)—computers and shared peripherals connected together in a small area, usually within a building, enabling two-way communication between devices. A LAN can consist of anything from two Macs connected to a laser printer, to hundreds of mixed devices on an Ethernet cable. This chapter will tell you everything you need to know about the plumbing required to create simple local area networks, including cabling systems, signal transmitting and receiving hardware, and hardware that boosts network signals along the way. Networking doesn't stop at LANs: When you decide to network the networks, that is, when you connect two or more networks, you create an *internet*. Creating internets is the subject of Chapter 6.

Readers of this chapter and installers of Mac networks will find consistency throughout the Macintosh line as well as the concept of plug and play: Plug a Mac or a printer into an AppleTalk network, and it works. This is why even small businesses can set up a simple Mac LAN without hiring a connectivity specialist. Not that nothing ever goes wrong—troubleshooting will be discussed in Chapter 12—but Macs do come out of the box ready to network and can be put together with the knowledge of just a few basic concepts. All of this is made possible by a special ingredient built into every Macintosh since it was first introduced—AppleTalk.

Built In: AppleTalk

AppleTalk's ease of use and platform and media independence have made it a very successful networking scheme. By 1990, there were over 2 million Mac and non-Mac *nodes*. A node is any network device, such as a Mac or a printer, that has a unique network address. By 1992, that number had increased to over five million. AppleTalk has also been licensed by Apple to manufacturers of other computers and operating systems: Digital Equipment Corporation, Novell, Sony for its News UNIX workstations, and Go for its PenPoint operating system for pen-based computers. Even IBM has licensed AppleTalk for its OS/2 server. Just what is it that everyone is interested in?

AppleTalk is not a cable, nor is it a connector. AppleTalk is a complete description of a networking system, from the sending and receiving of basic signals over wire to the multiuser applications and network services that users share. AppleTalk defines a set of *protocols*, rules describing the signals sent over the network to accomplish certain tasks, as well as how hardware and software should act when these signals are sent and received. (I'll describe some of these protocols in Chapter 12.) AppleTalk protocols are applicable to networking in LAN, internet, and wide-area situations.

Strictly speaking, there is no such thing as an AppleTalk cable or connector. AppleTalk is independent of the transmission media, the cables or radio waves used to carry signals. AppleTalk isn't even restricted to the Macintosh.

AppleTalk is modular in design, letting you choose and mix the cabling and types of computers with which you need to work. AppleTalk can connect to other types of network schemes, such as DECnet and TCP/IP, which I'll discuss in later chapters. Mac users don't even have to be aware that they are connected to these foreign networks. Macintosh users access services on other types of computers in the same way that they access services residing on other Macs, which in turn is similar to the way they access hard disks on a stand-alone Mac.

AppleTalk can also run on a variety of *data link mechanisms*, also called physical links; these are the pieces of hardware and software on a computer, printer, or other network device that transmit and receive network signals. Common data link mechanisms that AppleTalk will run on include LocalTalk, Ethernet, and token ring.

LocalTalk, the original AppleTalk data link mechanism built into the Mac, is accessed through the printer port. This is an artifact from the days when the main purpose of LocalTalk (and AppleTalk) was to connect multiple Macs to laser printers. Most Mac network printers have LocalTalk ports, which the manufacturers often incorrectly call AppleTalk ports.

The newer higher-end Mac models and peripherals, such as the Macintosh Quadra and the LaserWriter IIg have Ethernet built in, in addition to LocalTalk. Or, you can add Ethernet, as well as other data link mechanisms, to any Mac in a simple process described in the next section. Although switching between data link mechanisms can be an afternoon's worth of work on a PC, on a Mac, it's simply a matter of choosing an icon. Just go to the Network Control Panel, a standard piece of system software shown in Figure 5.1, and click on the data link you desire. (This figure shows four possible data link drivers, the names of which end with *Talk*.) The Network Control Panel looks and acts similarly to the Startup Disk Control Panel, which is used to select the hard drive from which you boot.

Other pieces of software in the Mac's operating system that control AppleTalk networking are not apparent to users—that is, users don't even need to know they exist. In fact, you need to do very little to set up AppleTalk. When the System is first installed, AppleTalk is automatically activated. A button in the Chooser lets you turn off AppleTalk if you are not connected to a network and are using the printer port for a non-network device, such as a QuickDraw printer.

■ Choosing a Data Link Mechanism

Data link mechanisms are the pumps that push data over networks. Like pumps, they can be used on a variety of pipes, or cable systems. Unlike water moved by a pump, however, data is not sent in a continuous stream, but in

discrete bits at certain intervals. The number of bits each data link mechanism sends out per second is fixed. Although the effective rate of transport may be slower because a Mac has to re-send data, it can't get any faster, regardless of the cable type used.

Figure 5.1

The Network Control Panel lets you switch between data link mechanisms with the click of a mouse button.

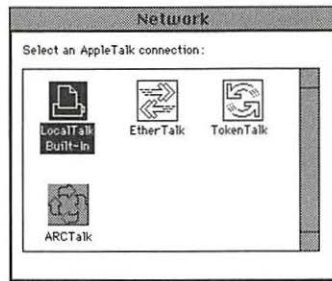

Your decision about which data link mechanism to use will be based on cost, speed, flexibility, and type of computer. Like Macs, PCs can make use of all of the data link mechanisms described below—LocalTalk, Ethernet, token ring, and ARCnet. If you decide on a data link mechanism that is not built into your Mac, you'll need to add a network interface card to one of the Mac's slots and drop a software driver into the System Folder. The interface card you get is also determined by the type of cabling you choose, so be sure to be thinking about both when you shop for an Ethernet or a token ring card.

LocalTalk

LocalTalk is designed for small- to medium-sized networks, and can theoretically accommodate up to 254 nodes on a single network, depending on the cabling system used. LocalTalk is still the most popular Macintosh network data link mechanism, as well as the simplest to set up and alter. You just plug in an inexpensive plastic media adapter (such as Farallon's PhoneNET) to your Mac's printer port, add a bit of cable, and you've got a LocalTalk network.

At 230.4 kilobits (Kbits) per second, LocalTalk is a much faster alternative to an ordinary serial link, but it's the slowest of any network data link mechanism available to the Mac. This speed limitation starts to show when more than two or three dozen nodes are connected, or when large amounts of data are passed around or printed, as is common with applications such as desktop prepress, multiuser database, or CAD. Another limitation is that LocalTalk is not a multiprotocol data link—it can't run non-AppleTalk networking schemes such as TCP/IP or DECnet. For these, Ethernet or token ring must be used.

Still, LocalTalk is quite sufficient for small networks that handle ordinary business documents. Small LocalTalk networks can be set up and running minutes after the Macs are unpacked from their boxes, so many companies use LocalTalk as a cheap temporary network until more complex networks can be put together. Because it is built into every Mac and many laser printers, LocalTalk has one of the best price/performance ratios of any networking scheme available on any platform. LocalTalk is also very flexible, allowing you to unplug any node without breaking the LAN in two or bringing down the entire network.

Ethernet

Ethernet is the most popular data link mechanism for networks containing PCs, UNIX workstations, and DEC VAX minicomputers, and is rapidly gaining popularity with people who design and run AppleTalk networks. Ethernet broadcasts data on the network at a transmission rate of 10 megabits (Mbits) per second. Ethernet is defined by a set of industry standards, the IEEE (Institute of Electrical and Electronic Engineers). One popular version, 10BaseT, specifies Ethernet transmission over twisted-pair telephone wire.

The IEEE 802.3 standards are followed by Apple and other makers of Ethernet cards and software for the Mac, enabling Mac users to join networks of PCs, workstations, and minicomputers. The AppleTalk software driver for Ethernet is called EtherTalk, which consists of a small (15k) file that is put in the System Folder. The EtherTalk driver usually comes with the add-in card or System 7.

Ethernet interface cards are widely available for most Mac models from a variety of vendors, and have been dropping in price over the past few years. External Ethernet adapters that attach to a Mac's SCSI port are available for those Macs without slots, although performance is less than with add-in cards. For one-slot Macs such as the Mac LC and the IIx, several vendors offer a combination video/Ethernet card. LocalTalk laser printers without built-in Ethernet can be put on Ethernet with an external device designed for printers, such as Dayna Communications's EtherPrint.

Ethernet can run on a wide variety of cable types, each requiring a different connector. Most Ethernet adapter cards usually have one type of connector on them, a problem if your organization uses several Ethernet cabling schemes and you tend to move your Macs around. One solution is Ethernet cards that have more than one connector on them, such as cards offered by Asanté.

A particularly practical solution to the problem of adapter cards with only one type of connector is Apple's Ethernet Cable System, unofficially called "friendly-net," a name that was picked up by Asanté. Apple's system separates the Ethernet hardware into two parts, internal interface boards for NuBus and the Mac LC, and external transceiver adapters, which receive

and send Ethernet signals. Once you install an interface card, you need to change the external adapter only when you switch cabling systems. The transceiver adapters also fit on the built-in Ethernet ports of the Mac Quadra. There are three external adapters, one for thin coaxial cable, one for twisted-pair cable, and one that has an industry-standard AUI (attachment unit interface) port, which can connect to coaxial cable, fiber-optic cable, and other media. Friendly-net adapters are also available from third-party vendors.

When Packets Collide

LocalTalk and Ethernet are similar in the way they send messages over the network: They are both *broadcast* mechanisms. A group of bits, organized into a unit called a *packet*, is broadcast over a network to all nodes at once, regardless of to which nodes it is addressed. Although all nodes receive every message, each packet contains an address for one or more specific nodes, so packets that are not addressed to the receiving node are ignored.

A normal effect of packet broadcasting is the packet collision, which occurs when two or more network devices broadcast a message at the same time (see Figure 5.2). Collisions are a normal part of LocalTalk and Ethernet networks and are recognized as such, so messages are re-sent when collisions occur. LocalTalk protocols use collision-avoidance methods to prevent collisions from occurring continually. Ethernet uses a method called collision detection to avoid constant collisions. However, neither of these methods completely eliminates collisions.

Figure 5.2

Packet collisions occur with LocalTalk and Ethernet when two or more nodes broadcast a message at the same time. Packets will be re-sent when the Macs realize their messages weren't received.

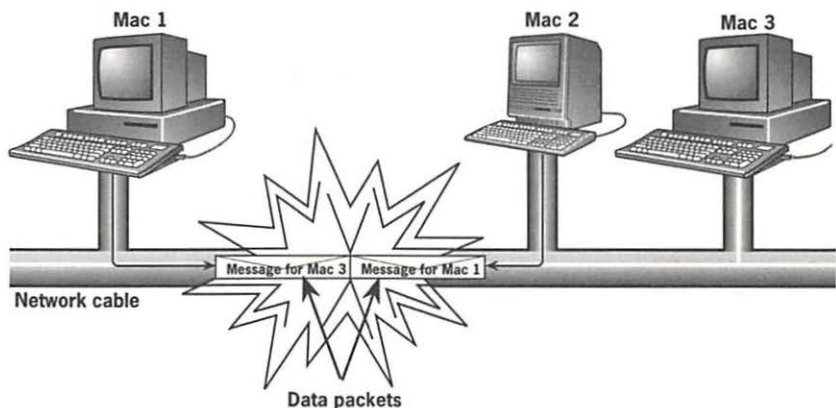

With collisions and the need to re-send packets present, throughput never actually reaches the transmission rate of 230.4 Kbits per second for LocalTalk and 10 Mbits per second for Ethernet. The more nodes on a network, and the more traffic each node produces, the more network throughput deteriorates. Although Ethernet's rated transmission rate is 40 times that of LocalTalk, MacUser Labs has shown the actual performance of Ethernet to be about two to five times faster than LocalTalk. This throughput difference between LocalTalk and Ethernet increases under more heavily loaded conditions, since LocalTalk throughput deteriorates faster than Ethernet.

Collisions alone don't account for all of the slowdown of LocalTalk and Ethernet. In addition to the data you are sending, the data links produce their own traffic, called *protocol overhead*, which identify packets to the receiving computer and manage the transferring of data over the network. An application such as an electronic mail server that sends out a lot of small-sized packets creates more protocol overhead than one that sends out fewer large packets.

In addition, the top throughput of Ethernet is limited by bottlenecks in your Mac—the hard disk or NuBus that can't accept data as fast as Ethernet can send it. (LocalTalk is not fast enough to be greatly affected by Mac hardware bottlenecks.) The amount of Ethernet slowdown due to bottlenecks depends on the Mac model and its hardware configuration. Asanté has an Ethernet card for the Mac IIfx that eliminates the bottleneck caused by NuBus; the card fits in the fx's direct-processor slot, which is a quicker path to the Mac's CPU than is NuBus.

Token Ring

Some data link mechanisms use a scheme called *token passing*, which doesn't have collisions, as seen with the broadcast schemes. Token ring, defined by the IEEE 802.5 specification, is the most popular token-passing data link mechanism. A token ring network is set up as a logical ring. Instead of every node sending messages any time it wants, messages are sent only to the next computer in the ring in a one-way direction. A node can only send a message when it receives a command called a token, which is passed from computer to computer. (See Figure 5.3.) When a computer waiting for the token receives it, the computer holds the token and sends out a busy signal followed by the message to the next computer on the ring. The receiving computer accepts only messages addressed to it; otherwise, it passes the message to the next

device on the ring. Because messages don't have to be re-sent as the result of collisions, throughput on a token ring network degrades at an even, predictably low rate as the number of nodes increases.

Figure 5.3

Token ring networks send messages from one node to the next; only the node with the permission token is allowed to send a message. Other nodes wait to receive the token before sending messages.

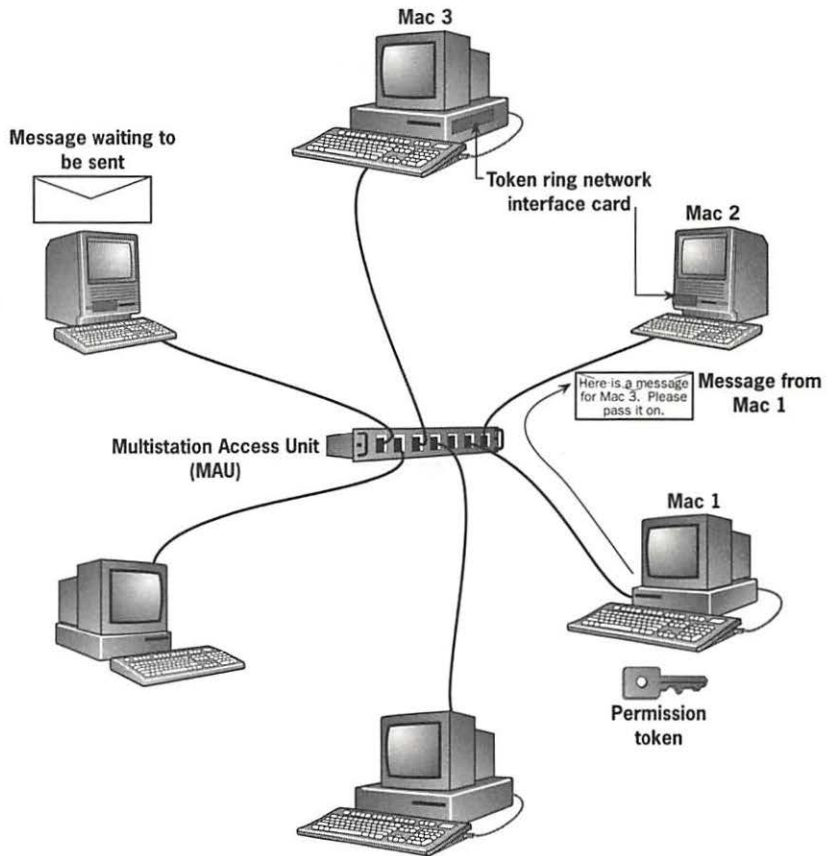

There is some actual deterioration of throughput with large numbers of nodes, but this is far less than seen with Ethernet. Token ring operates at two speeds, 4 Mbits per second and 16 Mbits per second. However, it's difficult to directly compare network performance to that of Ethernet because of the many other factors such as interface cards and Mac network software. In addition, because of bottlenecks in hardware, the 16-Mbit-per-second token ring may not improve performance over the 4-Mbit-per-second version for smaller networks, but it should help slow throughput deterioration as the number of nodes grows on very large networks.

Token ring is the third most significant data link mechanism that runs under AppleTalk after LocalTalk and Ethernet. Token ring, IBM's official solution for connecting IBM PCs and mainframes to the same local area network, is popular in banking and finance. However, token ring is not used to connect to DEC VAXes or UNIX workstations. Although a few Mac-only token ring networks exist, some of which are quite large, most Macs running token ring were added to existing token ring installations. Token ring is prohibitively expensive for small sites.

Token ring is more difficult to install than either Ethernet or LocalTalk, and requires more maintenance. You'll need a piece of hardware called a multistation access unit (MAU), which you can purchase from IBM and other vendors. Macs can get on token ring with an interface card that runs at either 4 or 16 Mbits per second, although some boards have the ability to switch between the two speeds. You'll also need the TokenTalk driver, which, like the LocalTalk and EtherTalk drivers, appears in the Network Control Panel.

ARCnet

ARCnet is not common on Mac networks, but is the number three network data link mechanism in the PC market behind Ethernet and token ring. ARCnet is well-regarded for its reliability and low cost and is easier to maintain than a token ring network.

ARCnet uses a combination of the Ethernet and token ring approaches: It is a broadcasting mechanism with token passing. Like token ring, computers on ARCnet can't send messages until they receive a token. Permission to speak is granted by the controller computer, which is simply the node with the lowest identification number; you set this on the interface card. Instead of passing a token from one computer to the next, the ARCnet controller broadcasts a permission token over the network. Although all nodes receive the broadcast, the token grants permission to only one computer. The computer with the token then broadcasts its message on the network. Since only one node is broadcasting at a time, no packet collisions can occur. After the message is sent, the controller computer sends out a new permission token for another node. ARCnet sends out data at the rate of 2.5 Mbits per second.

ARCnet interface cards are available for the Mac's NuBus slot and for the direct processor slots in the Mac SE and SE/30 from two sources, Standard Microsystems Corporation (known as SMC) and ACTINET. Cards are available for either twisted-pair or coaxial cable. Apple does not make any ARCnet products. The software driver for Macs, called (surprise!) ARCTalk, is supplied by the interface card vendors.

FDDI

AppleTalk is not limited to the data links currently in use—any vendor can develop a new data link driver and Mac network interface card to run under AppleTalk. The newest data link for Macs is FDDI, short for *Fiber Distributed Data Interface*, a token-passing ring that runs at 100 Mbits per second, ten times the transmission rate of Ethernet. FDDI originally required fiber-optic cabling to connect PCs, UNIX workstations, and mainframes, but now also runs on wire cabling. It is usually used for big networks that span a fairly large distance, such as a corporate or university campus, and where applications such as multimedia need to be used over a network.

The first FDDI access method for Macs is the Stallion NuBus card with FiberTalk software from Team Advanced Systems Associates. Stallion/FiberTalk turns a Mac into a gateway to any AppleTalk network. We can expect more FDDI products to appear as costs for the technology come down and as FDDI gains acceptance on other platforms.

■ Choosing Media

Most of the transport mechanisms will work over a variety of signal carriers, called media, including wire cable in twisted-pair or coaxial form, glass fiber-optic cable, and wireless infrared or radio frequency waves. Typical decision-making factors include cost, availability, ease of installation, how well the media fits into your current network setup, and how often you change your setup. You'll usually find a trade-off between cost and how well the media is shielded against interference from electromagnetic fields created by fluorescent lights, motors, and power supplies. Interference can slow network performance by damaging packets on the line, causing messages to be re-sent. The better the shielding, the longer the maximum allowable length of cable used in a network.

Although network performance is most affected by the data link mechanism you use, the media can be a factor on big networks using high-bandwidth protocols. These networks require a well-shielded cable, a media with a high immunity to interference, or a device on the network that boosts signals; otherwise, signals will fade and be lost after traveling short distances.

Twisted-Pair

Twisted-pair is the most common cable for AppleTalk networks, mostly because it is inexpensive and easy to install, being thin and flexible for fitting in tight spaces and bending around corners. Of the two types of twisted-pair cabling, shielded and unshielded, the latter is the cheaper and more popular, mostly because it is the same as modern telephone cabling. Since telephone

cabling often contains two, four, or more pairs of wires, an office can be wired for telephone and LAN service with a single cable.

Whether you run telephone and data on the same cable or install a separate data cable, twisted-pair is a very convenient wiring setup, since the existing telephone closets can be used to locate the network punch-down blocks that connect the wires coming from each node. The central location makes twisted-pair easier to install, to modify, and to troubleshoot than other cabling systems.

New cabling may be required if you are not building an office from scratch. There may not be enough pairs for the phone system and the LAN, so new wire will need to be run. LocalTalk requires one pair of wires; 10BaseT Ethernet requires two pairs. A no-frills phone uses a single pair, but additional pairs are required with more full-featured phone sets. Still, using telephone wire is a bonus, since a lot of contractors and technicians are familiar with techniques of connecting and terminating telephone wires.

Twisted-pair gets its name from the pairs of cables that are twisted around each other, as shown in Figure 5.4. The twisting provides some protection from interference caused by stray electromagnetic fields emanating from fluorescent lights and motors. The shielding, a layer of metal foil or woven copper around each pair, adds further interference protection. Unshielded twisted-pair often requires a device to boost signals, such as a star hub, discussed below. A stranded-wire telephone cable known as flat silver, often used for short runs between a wall socket and a phone or computer, has properties similar to unshielded twisted-pair.

Figure 5.4

Unshielded twisted-pair LAN cable is the same media used for wiring telephone systems in offices and homes.

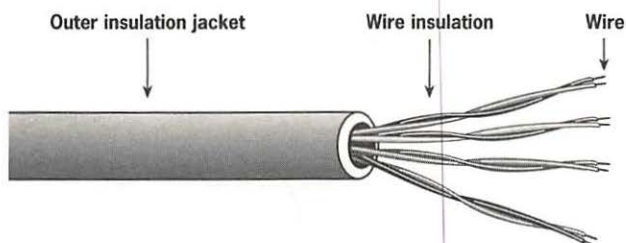

Twisted-pair works well in an office environment, but is not recommended for industrial settings, where transformers, electric motors, and other generators of electromagnetic fields are abundant. The flexibility of the cable also makes it prone to physical damage: Severe bending of the cable, or even stepping on it, can break a connection. Twisted-pair cabling is also the least secure network cabling system—its relatively low degree of shielding also enables the signals passing through the cable to produce an electromagnetic

field around the cable. This field can be easily tapped to reveal the signals passing on the cable.

Almost all LocalTalk networks use twisted-pair, either shielded or unshielded. The original LocalTalk cable supplied by Apple is a shielded type. Farallon's PhoneNET cabling is unshielded. The 10BaseT standard for Ethernet also uses unshielded twisted-pair, but makes up for the lack of shielding by requiring a star hub to boost signals (star hubs are discussed later in this chapter). Token ring can use shielded or unshielded twisted-pair for both 4- and 16-Mbits per second transmission rates.

Unshielded twisted-pair and flat silver cables for LocalTalk end with the same 4-pin RJ-11 connectors and jacks used for telephones and modems. Twisted-pair cables for 10BaseT Ethernet use similar, but slightly larger 8-pin RJ-45 connectors. RJ-11 plugs will fit and actually work in RJ-45 jacks.

Twisted-pair comes in different gauge thickness; the lower the number, the thicker the cable. Unshielded twisted-pair 24 AWG (American Wire Gauge) is standard for LocalTalk and 10BaseT Ethernet. Token ring uses IBM gauge standards, IBM Type 1 for shielded and IBM Type 3 for unshielded are typical.

Coaxial Cabling

Coaxial cable is more expensive than twisted-pair, but is better suited to industrial and interference-intensive environments and to LANs with computers spread out over longer distances. Figure 5.5 shows why: The central wire (solid or stranded) is wrapped in an insulating plastic layer, which is covered with a metallic electromagnetic shield, which in turn is surrounded by an outer layer of plastic.

Figure 5.5

Coaxial cable is well shielded from interference, but is more expensive than unshielded twisted-pair.

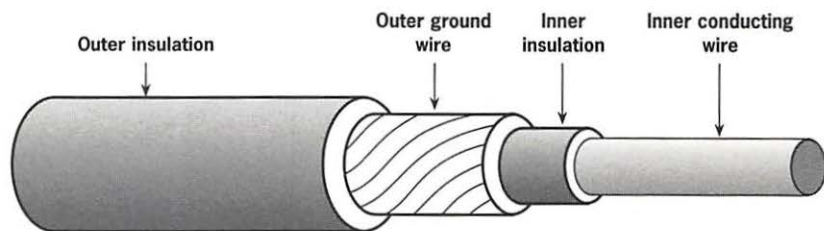

Two types of coaxial cable, thicknet and thinnet, are used in LANs. Thick coax, or thicknet, is a rigid cable about ½ inch in diameter, making it an expensive cable. Its rigidity and size prevent thicknet from being connected directly to computers. Instead, it is usually laid in the floor or ceiling with thinner transceiver cables branching off from transceiver connectors. Because of thicknet's

high cost and difficult installation, it is not favored for use indoors, but is common for connecting buildings, for example, on a campus.

Thin coax, or thinnet, is easier to work with in an office, measuring about $\frac{3}{16}$ inch in diameter. Thinnet is close in appearance to the cable used for cable television and has similar types of connectors. Thinnet cable often terminates with a BNC connector, a small metal cylinder that locks with a half twist. A BNC connector attaches two cables to a T-connector, which can attach directly to a Mac's network interface card, as shown in Figure 5.6.

Figure 5.6

Thinnet coaxial cable often uses a T-connector to plug into a computer.

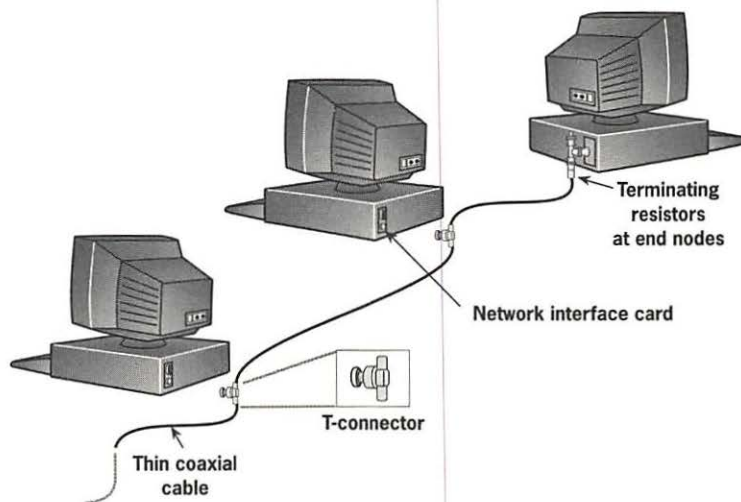

The various data link mechanisms require coaxial cable with different impedance ratings. Ethernet uses coaxial cable rated at RG-58; ARCnet uses RG-62. LocalTalk doesn't use coaxial cable, so connectors aren't available. The reason is not a technical incompatibility, but simply that coaxial cable is a bit of overkill for LocalTalk, since coaxial cable can carry far more data than LocalTalk can transmit.

Fiber-Optic Cabling

Fiber-optic cabling, used on some long-distance telephone lines to produce clear, distortion-free connections, is also available for use in local area networks. Instead of moving electrons on copper wire, fiber-optic networks send pulses of light through tiny glass fibers (see Figure 5.7). The glass fibers have diameters typically in the 100-micron range. (A micron is one millionth of a meter; 100 microns is about four one-thousandths of an inch.) The glass fibers are coated with a thin layer of reflective material, typically acrylate, to

keep the light within the glass core. This is encased in an inner jacket of teflon. Despite the fact that the fibers are made of glass, fiber-optic cabling is quite robust due to a layer of tough Kevlar padding before the outer jacket.

Figure 5.7

Fiber-optic cabling transmits network signals with pulses of light over hair-thin glass fibers.

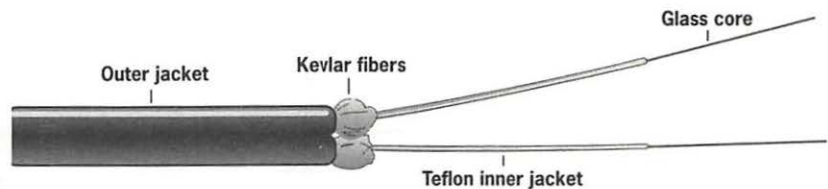

Fiber, the highest-quality network cabling available, gives you the longest cable runs and the most reliable and secure data transmission. As such, fiber-optic components are not commodity products like Ethernet boards; fiber represents a fairly sizable investment. Installation is also not cheap; it requires highly specialized technicians to perform delicate alignment procedures using exotic connectors.

The maximum allowable distance can vary with each system, but it is possible to set up a fiber local area network with each node in a different building. With the use of optical repeaters, devices that boost signals, a local area network can be extended for several miles. Light traveling through glass encounters much less resistance than electrical signals traveling through metal, so fiber-optic signals degrade at a much slower rate.

In addition, fiber-optic cable is virtually unaffected by even strong electromagnetic fields. This is a big contrast to metal cabling, which, even with shielding, absorbs energy that can distort network signals. You may have noticed an example of this phenomenon at home, when the power cord of a radio or TV annoyingly acts as an antenna. In addition to being affected by electromagnetic fields, the signals traveling through wire cabling also *produce* electromagnetic fields. Anyone with equipment to measure these fields can read the messages going across the network. Fiber is a secure medium: It produces virtually no electromagnetic fields that could be picked up and decoded by people who shouldn't be listening. Fiber is also very difficult to physically tap into, since splices are not easily made.

A common misconception is that fiber-optic cabling is faster than copper cabling. In fact, electrons moving on metal wire move nearly as fast as light through glass; fiber does not increase speed. Remember, no cabling system can make the network any faster than the speed at which the data link mechanism sends out data. Ethernet transmits at the same 10 Mbits per second bits on fiber-optic cable as it does on unshielded twisted-pair.

Token ring also operates on fiber at its standard transmission rates. However, because fiber-optic cable has a very high bandwidth, it has the potential of carrying a lot of network traffic at very high data transfer rates. Telephone companies already use fiber to carry hundreds of telephone conversations over a single cable. Realizing this, the IEEE 802.3 committee has drafted a new standard for Ethernet of fiber-optic cable, called 10BaseF (the *F* stands for *fiber*, just as the *T* stands for *twisted-pair* in 10BaseT). This standard, when adopted by makers of fiber-optic Ethernet products, will allow the hardware of different vendors to work with each other on the same network. Although 10BaseF still transmits data at the old rate of 10 Mbits per second, it allows for future changes that would take advantage of fiber's bandwidth and exceed the current Ethernet speed limit. Even so, fiber-optic cabling may have a more important role to play in wide-area networking, which I'll discuss in Chapter 13.

Fiber-Optic Products

A major player in fiber-optic LANs is Du Pont, whose first Mac market was a fiber-optic system for LocalTalk. This product was dropped for the same reasons coaxial cable is not used with LocalTalk: The cable bandwidth far exceeds LocalTalk's capabilities. Du Pont's current LAN ONE fiber-optic product line can be used with Ethernet and token ring. You'll need a standard AUI port in your Mac to connect to an AppleTalk-fiber converter unit. The converter translates the electronic signals used by your Mac and the light signals on the fiber-optic network. You can connect a network of Macs on wire cable to an optical LAN with an AppleTalk-fiber extender unit.

Digital Communications Associates (DCA) offers a fiber-optic token ring network interface card for the Mac, the MacIrmatrix Fiber. Like the Du Pont Ethernet system, DCA's fiber token ring system requires a converter, in this case called a ring interface module, to convert optical and electrical signals.

Going Wireless

The newest option for network media is to eliminate cables altogether. In a wireless setup, signals are transmitted with electromagnetic radiation through the air, just as is done with radios, satellite communication, and VCR remote controls. Applying this technology to connecting personal computers is still mostly in the research phase, but there are some systems you can buy today. These systems cost more than twisted-pair or coaxial cable schemes, but offer measurable benefits to certain classes of users. Since there are no cables to install, wireless networks are easy to set up, and are particularly useful where frequent rebuilding is necessary. Wireless networks are also seen as a great step forward in connectivity for portable computers,

particularly in non-office environments. Portable computer users could connect to a network simply by walking into a room. But with small wireless transceivers, not only would the computer be portable, but the LAN would be as well. Ad hoc networks could be created at conferences, off-site meetings, and in classrooms.

For local area networks, the technologies boil down to the use of two frequency bands—infrared and radio frequency (RF). Infrared is the more established technology; a LocalTalk product has been on the market for several years now. Because the infrared spectrum is not used for general long-distance communications, infrared transmission is free from the regulatory maze that is involved with RF communications. However, RF is the most promising in terms of portability and flexibility.

Infrared Networks

The first wireless LAN media packages use invisible infrared light to transmit signals aimed at a target, much as is done by television remote controls. Infrared as a LAN media is not practical in situations where nodes are located in different offices or other rooms, but it is well suited for factory floors and other locations with open spaces and the need for frequent rearrangement of a network.

PhotoLink from Photonics is a wireless LocalTalk setup that uses a communications method called *directed transmission*: Two or more infrared transceivers, which can be connected to up to four Macs, beam their signals to a central target, which could be just a spot on a wall or ceiling (see Figure 5.8). Up to 32 transceivers can point at a single target, as long as they are all located within a 70-foot diameter area.

Photonics also produces a version of PhotoLink that uses point-to-point transmission for communications between two buildings up to 600 feet apart; the transceivers are aimed directly at each other. PhotoLink Building-to-Building is used to connect LocalTalk networks in each building in a transparent manner.

A new type of infrared communication, called *diffuse transmission*, is being developed by Photonics. This method would bounce infrared signals off of everyday objects—walls, tables, and people—making it possible to pick up a signal anywhere in a room. Since no aiming or focusing is necessary, diffuse transmission would be ideal for networking computers that are moved around, such as laptops and pen-based computers.

Another product, InfraLAN from BICC Communications, is a system similar to PhotoLink but uses 4-Mbit per second token ring instead of LocalTalk. The system is based around token ring multistation access units (MAU) that use standard token ring cards. Each MAU can support up to six Macs or PCs. Each MAU is also connected to two infrared transceivers,

Figure 5.8

PhotoLink uses infrared waves to send LocalTalk packets between transceivers.

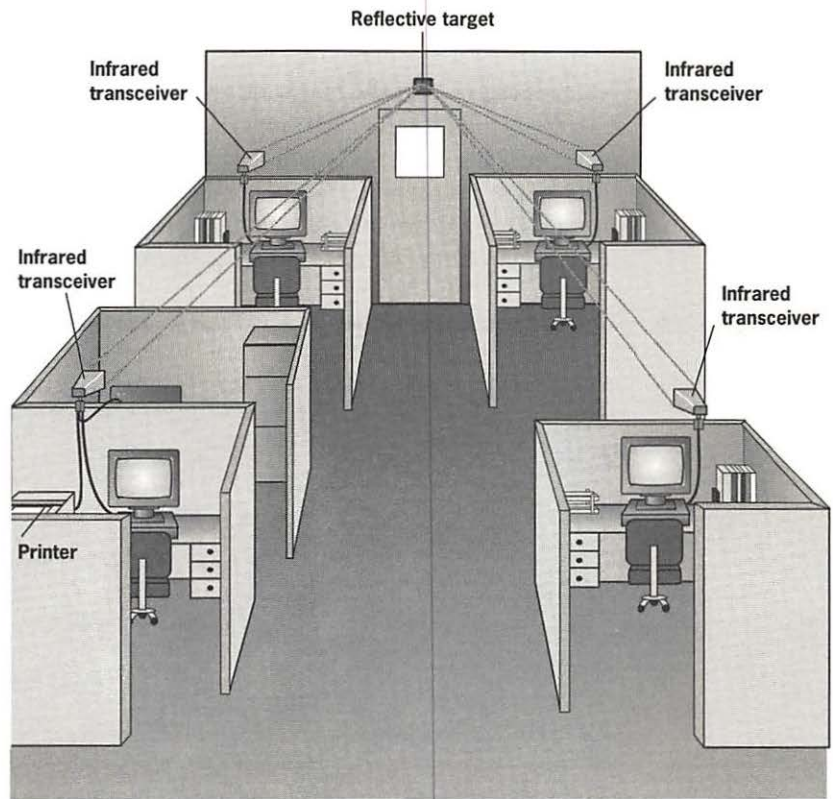

which are aimed directly at transceivers connected to other MAUs. Infra-LAN can be integrated with standard cable-based token ring networks. No infrared Ethernet systems currently exist, but a 1-Mbit-per-second, Ethernet-clone system is in the works.

Radio Frequency Communication

Radio frequency (RF) local area networking is farther behind in development than infrared, but promises to be a more flexible wireless solution, mainly because RF can go through walls, which diffuse infrared can't. In addition, RF radio transceivers can be produced in very small packages, establishing the possibility of the ad hoc network—two or more portables would come together briefly and form a LAN not only in an office, but on the road, in a hotel conference room, or even outdoors.

Many problems with RF have yet to be solved. The main one is finding a frequency range to dedicate for wireless LANs. Although the military has

been opening up some previously locked frequencies, the radio spectrum has for years been carved up and reserved for specific purposes, such as flight communications, television, and cellular telephones (see Figure 5.9). Radio transmission is regulated by the Federal Communications Commission, which looks out for the many industries competing for the few remaining free frequencies. Other frequencies require licensing fees by the users, which is not very practical for a company to do for its LANs. In addition, not all frequencies are suitable for LAN communications. There is a trade-off between broadcast range and transmission speed; these factors must be delicately balanced in order for wireless LANs to become practical.

Figure 5.9

The electromagnetic spectrum

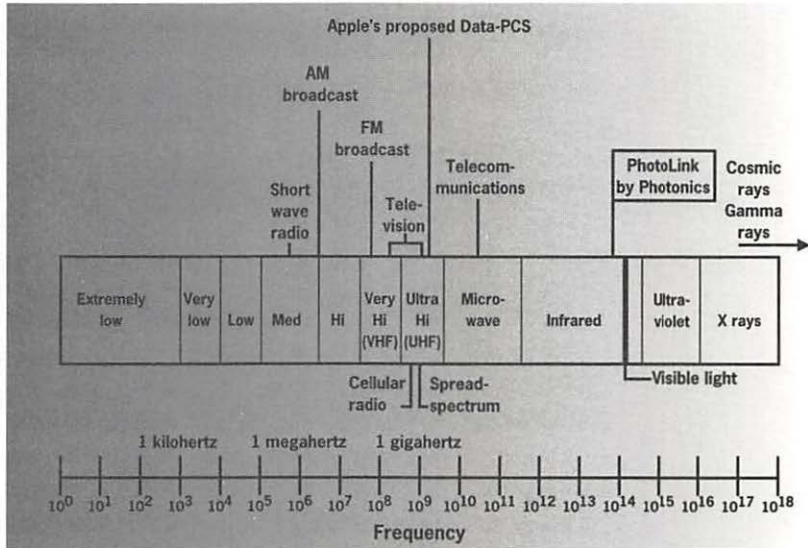

The first place the RF LAN products are appearing is in the Industrial, Scientific and Medical (ISM) frequency range, which lies near the UHF and microwave bands of the spectrum, where telecommunications and broadcasting take place. Part 15 of the FCC Rules requires broadcasters on most microwave frequencies to obtain a license, but the FCC has set aside a few bandwidth slivers in the microwave range for license-free transmission. These are the ISM bands. The FCC requires users of the ISM bands to transmit using one of several techniques known as *spread-spectrum modulation*: spreading the signal evenly across a frequency band. Spread-spectrum modulation works well as far as data integrity, but is not ideal for wireless LANs. The main problem is that the ISM bands are not dedicated to LAN users—they must be shared with other industrial users. Since there is not enough

room for the potential demand of computer users, interference from industrial users is a big concern.

Apple has taken an interest in wireless networking, and in 1991 presented the FCC with a proposal to create a new high-performance radio networking band dedicated to computer networks. The proposal would create a new class of communications called Data-Personal Communication Services, or Data-PCS. Apple asked the FCC to set aside 40 MHz of bandwidth within the 1850-1990 MHz range, preferably 1850-1890 MHz, which Apple's testing has shown to have optimum propagation characteristics. The Data-PCS proposal would limit transmissions to 1 watt maximum power, which would allow several wireless networks to operate simultaneously at Ethernet speeds within an area of 50 meters on a single floor of a building. In effect, Data-PCS would be a kind of multi-channel walkie-talkie for computers.

The Data-PCS band would be open to all computer manufacturers to create products using existing data links and network protocols. Product vendors would pay any FCC fees. Unlike other radio bands, users of Data-PCS would not be required to obtain an operating license, which can be an arduous process.

The radio spectrum is considered a public asset, and is tightly regulated and completely allocated for specific uses. The reallocation of bands in the radio spectrum is a slow process, requiring time for advocates and opposing interests to give their sides of the story. Apple has proposed that Data-PCS be implemented in pieces. The first 10 MHz would be allocated with FCC approval, while the rest would become dedicated to Data-PCS over an eight-year period. The FCC has responded favorably to Apple's proposal, and has announced its intention to start allocating Data-PCS bands in 1992.

There are some radio networking products that use spread-spectrum modulation in the ISM band, as well as several spread-spectrum radios for serial-port links to Macs. WIN Data is developing an Ethernet spread spectrum. There are no LocalTalk radio products at present.

Motorola's Altair is a networking product that avoids the ISM band altogether. Altair uses a high microwave band that requires FCC licensing fees, which Motorola includes in the purchase price. Altair is not suitable for laptops, since the transceivers for its frequency range are too big and require more power than can be supplied by a battery.

■ Setting Up a Local Area Network

It's best to start putting together the pieces of a local area network after you've made some decisions about data link mechanisms and cabling schemes. You then need to think about the arrangement of the nodes on the network. Although you can just start stringing cables between Macs, you

may run into cable length limitations, which, if exceeded, can result in some very slow or nonfunctional networks.

You also have to decide which wires go to which Macs and peripherals and how to tie them together. You begin by stepping back and considering the overall shape, or topology, your network will have. Sometimes this is determined by the data link mechanism you use, and other times, you will have to make a choice.

There are four basic network shapes: bus, star, ring, and backbone. Although a token ring setup may look like a star to the eye, it is logically equivalent to a ring. LocalTalk, Ethernet, and ARCnet can be set up as either a bus or a star, but never as a ring.

Bus Topology

A bus topology, sometimes called a daisy chain, is the simplest network shape, in which each node is connected to one or two other nodes in a linear fashion. Each node has a single connection to the bus with some sort of T or Y connector. (Figure 5.6 is an example of a bus topology.) There are no loops or branches in a bus topology, and there are always two end nodes. You often need to terminate end nodes by plugging in a resistor in the connection box or wall jack, depending on the cabling scheme. A *self-terminating* cable or connector doesn't require you to add resistors on the end nodes.

Daisy chains are the simplest and least expensive LANs to set up, requiring no network equipment besides the cable and connectors. However, without repeaters or hubs to boost signals, you are limited in the maximum length of the wire you can use and in the maximum number of nodes. LocalTalk daisy chains running on twisted-pair cable are sufficient for small networks up to about 32 nodes; thinnet Ethernet buses can support up to 40 nodes on a single wire segment.

Star Topology

Star topology is the most common network configuration and the easiest to maintain. In this setup, each of the cables running from every node meet at a central wiring point, usually located in a utility closet. Here, the arms of the star usually originate at one or more *punch-down blocks*, wiring centers that allow for quick installation and modification of wiring, mainly because no stripping of wire is required. When you use a punching tool to push a wire between a pair of the block's clamps, the wire insulation is pierced and an electrical connection is made.

The computer end of the star's arms usually ends at a wall plug with a terminating resistor. A benefit of the star is that if one cable run is broken,

only one node goes down, leaving the rest of the network operational. On an Ethernet bus, one bad connection can bring down the entire network.

Passive Stars

If the central point of the star is a simple wiring panel with no electronics, the topology is called a *passive star*, which is supported in LocalTalk networks. Passive stars greatly limit the maximum allowable cable length and should only be used for small networks with a handful of nodes. Since a signal's strength is divided up among the arms of the star (see Figure 5.10), the maximum allowable cable length is calculated by dividing the length in a bus topology by the number of arms. For instance, using 24-gauge shielded twisted-pair wire, the 3,000-foot maximum cable length of a LocalTalk bus becomes 1,000 feet on a three-arm passive star, and 750 feet on a four-arm star. More than four arms is not recommended, as the added resistance of the terminators has a deleterious effect on signal transmission. Getting five-or-more-arm passive stars to work often involves some guesswork and black magic, and you may have to try removing the fifth terminating resistor or relocating it to the center of the star.

Figure 5.10

Passive stars are limited to small networks, as a signal's strength is divided up among the arms of the star.

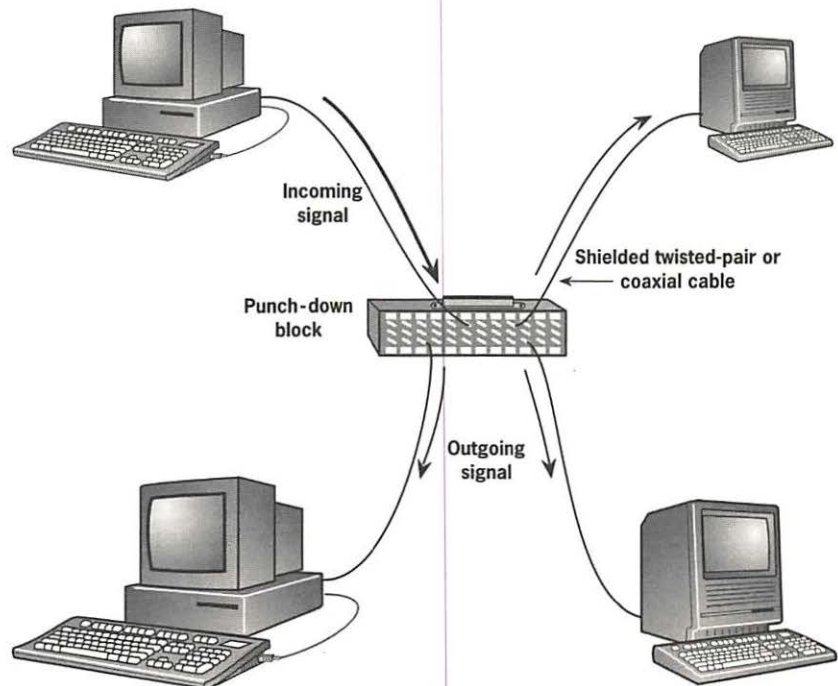

Active Stars

More common than the passive star is the active star, which uses hardware called a *star hub* to boost a signal received from a node and to send it to the other arms (see Figure 5.11). An active star *increases* the maximum cable length of the network, so that each arm can now have 3,000 feet of cable for itself. Another result of the signal boosting is that you can use the cheapest network cable, unshielded twisted-pair. With LocalTalk, multiple Macs can be daisy chained off of each arm, but it makes troubleshooting and network maintenance more difficult. No more than four nodes should be connected to any hub port. An exception to this rule is the fiber-optic hub, which is designed to have dozens of nodes connected to a port for Ethernet or token ring.

Star hubs are specific to the data link mechanism you choose: You can't use a LocalTalk hub in a 10BaseT network. Hubs typically have 8 to 24 ports each, which can be connected directly to the network cables, or to a punch-down block, which is then connected to the network cables. The latter is more convenient, since a punch-down block can be used to completely change the layout of your network without having to rip out and install network cable.

If you outgrow 24 ports, you can hook together multiple hubs. The hubs can be daisy chained together, or connected to a hierarchical hub in a hub-level star. (See Figure 5.12.) NRC's MultiGate FOIRL Fiber Optic Hub is a full-featured example that connects 10BaseT hubs used for workgroups of Macs in a star configuration, and connects them to a fiber-optic or coaxial backbone. (Backbones are described below.)

Hubs that are connected together don't have to be installed in one closet, and can be located close to the computers and printers. Token ring multistation access units (which look like and in some ways act like hubs) can be connected through special repeater boxes.

An alternative to wiring hubs together is to get a concentrator, which is basically a multi-hub hub. Concentrators usually have add-in slots for circuit boards, each of which is a hub. Quite often you can mix hub cards of different data link mechanisms and wiring schemes, so that one local area network can have both Ethernet and token ring parts, for instance. Concentrators are not always the best solution, as it may be more convenient to have the wiring going to several locations rather than to a single central location containing a confusing mass of cables. On the other hand, concentrators are sometimes used together with hubs in large networks.

By connecting hubs or using concentrators, you can quickly reach LocalTalk's theoretical maximum of 254 nodes on a single network (which would greatly overtax LocalTalk). 10BaseT Ethernet has no limit, but you'll eventually get to a point where you'll want to divide up the network into several separate, but still connected networks (more on this in the next chapter).

Figure 5.11

Active star topology can be used with LocalTalk, 10BaseT Ethernet, and ARCNet. The star hub boosts signals received from one arm and sends them to the remaining arms.

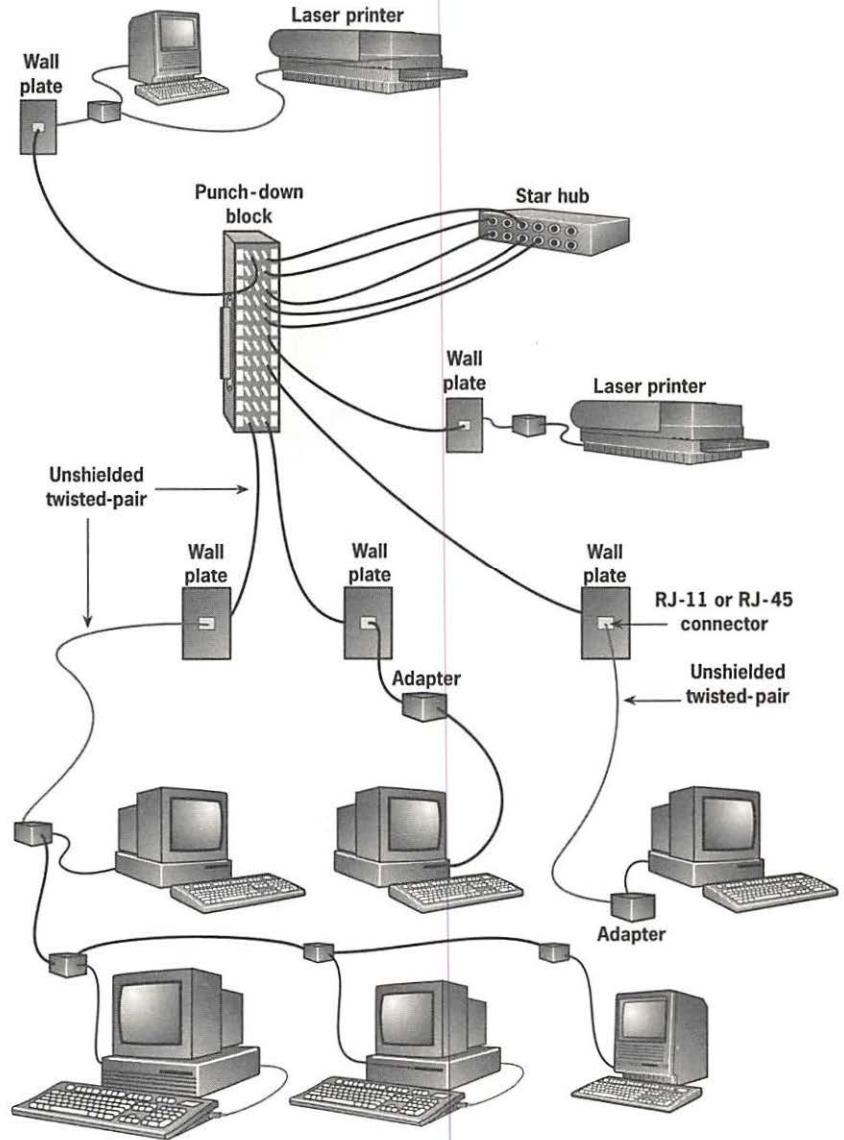

Figure 5.12

Hubs can be connected together to create a bigger LAN.
a.

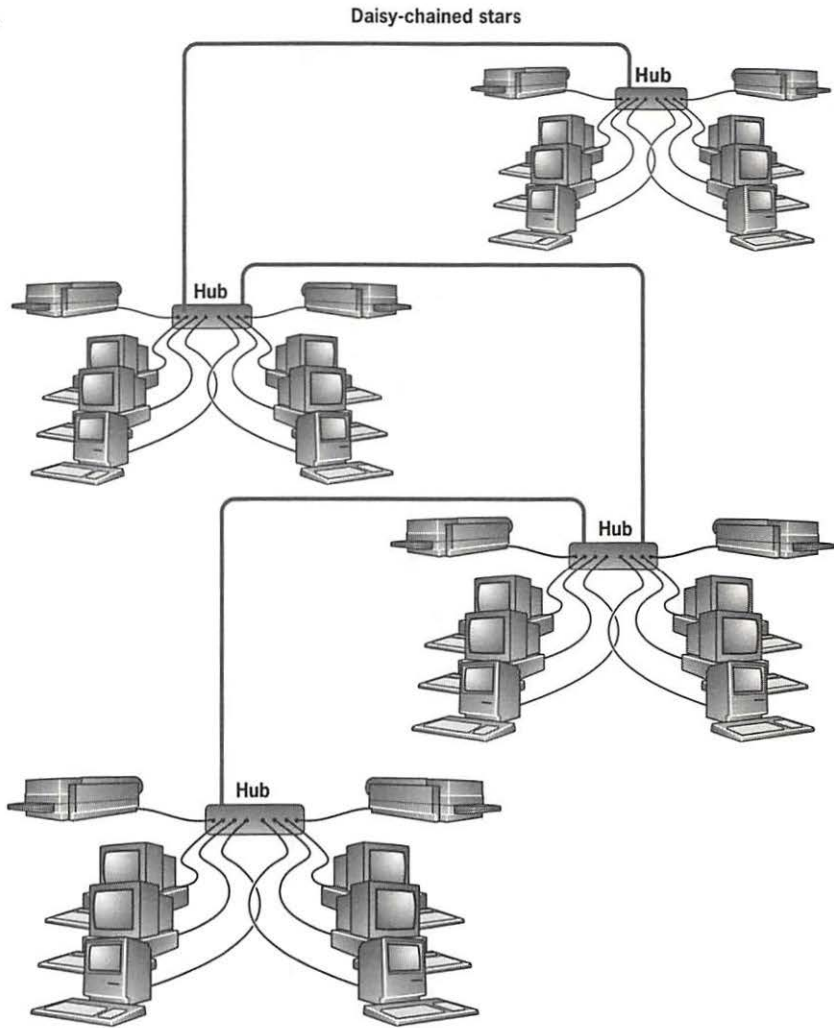
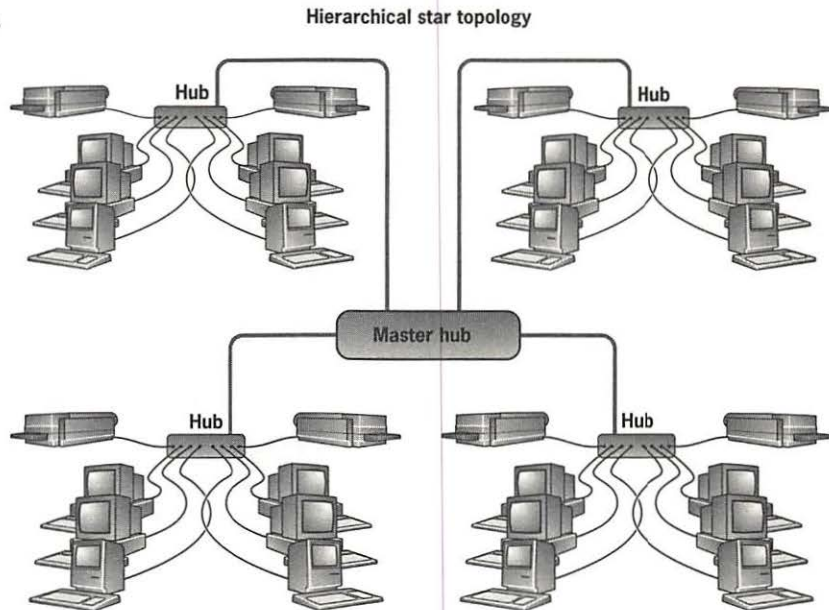

Figure 5.12

Hubs can be connected together to create a bigger LAN.



Another type of hub and concentrator you'll see advertised is the *intelligent hub*. These devices look at the data that is passing through them, and collect statistics on network traffic for use in fine-tuning a network design or in troubleshooting. Many intelligent hubs make use of the simple network management protocol (SNMP), an industry standard for collecting this type of data. I'll discuss these types of tools and other network management issues in Chapter 12.

Some hubs have some kind of method of control that enables you to do simple tasks such as shut down one or more of the hub's ports from your Mac. Some give you network access to the hub, and others make a serial link from the hub to a Mac. The network method is faster and gives you access to the hub from any Mac on the network, but will work only if the network is working, making it fairly useless for troubleshooting.

Backbone Topologies

Bigger networks usually need to make use of a *backbone topology*, consisting of a logically linear trunk, which supports several branches. Backbones act as a network's spinal column, channeling all the traffic that goes between branches. As such, a backbone should use a cable capable of supporting a high bandwidth, such as coax or fiber-optic. For instance, you can tie several

10BaseT star hubs together on a coax backbone. But a backbone is not simply a bus with branches; token rings can also be backbones.

Using routers, a backbone can also connect branches that are completely different in structure, such as an active star LocalTalk segment and a coaxial Ethernet bus. (See Figure 5.13.)

Figure 5.13

A backbone topology can use routers to connect multiple LANs into an internet.

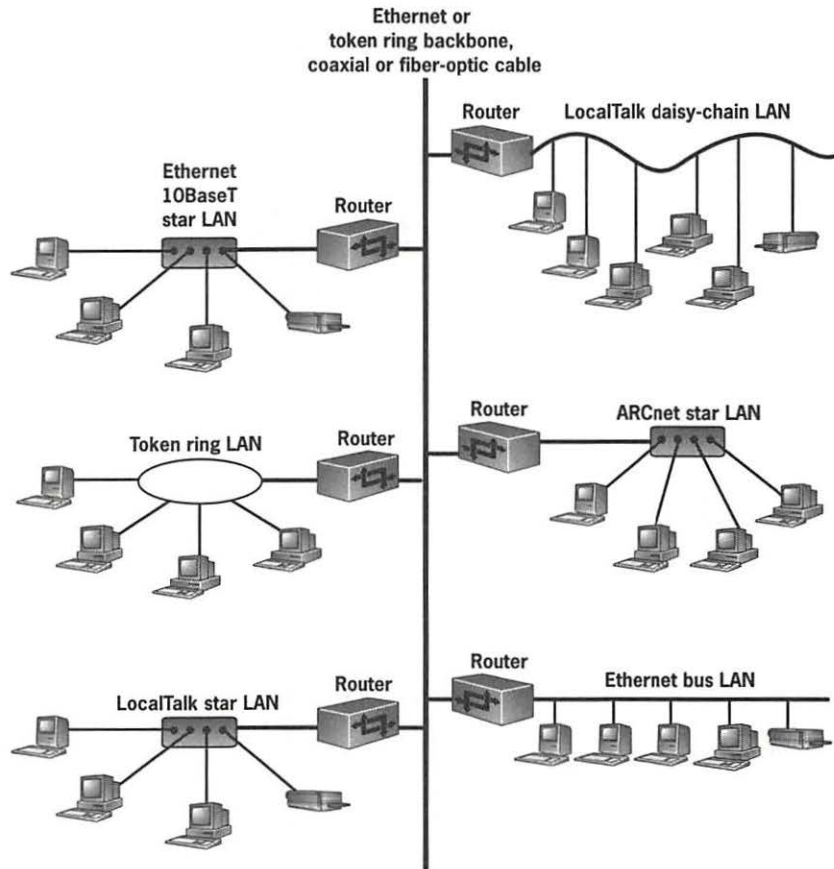

In fact, a backbone topology like the one shown in Figure 5.13 is not a local area network at all, but an internet, a collection of connected, yet autonomous networks bound together. Creating such an entity is the subject of the next chapter.

■ Looking Ahead

So far, the discussion has centered on the basic pieces you need for an individual network's plumbing: data link mechanism, transmission media, and hubs. In the upcoming chapter, you'll read about creating an internet, which will introduce a new set of plumbing issues—and more hardware. How your networks are connected together greatly affects internet performance. Complexity multiplies with each network you add to the internet, but fortunately, much of the plug-and-play aspect of individual AppleTalk networks is retained. Then again, there is no need to limit an internet to Appletalk.

- *Built In: AppleTalk Phase 2*
 - *Using Internet Building Blocks*
 - *Planning an Internet*
 - *Choosing a Router*
 - *Installing a Router*
-

C H A P T E R

6

Connecting LANs: Internets

IT IS LIKELY THAT AT SOME POINT IN A NETWORK'S GROWTH YOU will find yourself creating an *internet*—a network of networks. You may want to connect existing networks with different data link mechanisms (such as LocalTalk and Ethernet) or topologies (such as star and ring) to enable users on each LAN to share network services. Or, you might want to extend a network that has reached its maximum wire length. You might even need to create an internet by dividing up a single big LAN into two or more parts to improve performance.

This chapter is written for designers or would-be designers of internets. If you have no interest in creating your own internet, but, instead, are concerned about what networks can do for you, skip to Chapter 7. For those of you interested in a higher level of network plumbing, read on.

Building an internet can be a daunting proposal; each network you add greatly increases the complexity of the internet. Yet, whether you consider a big internet to be one with 100 nodes or 100 networks, the basic design concepts are the same. Individual AppleTalk networks are connected together by devices that control network traffic. Usually this device is a *router*, an element that routes data to destinations outside of a network. Just as importantly, it also keeps data addressed to a node within a network from spreading to other networks.

You can also connect networks using other types of traffic-control devices called bridges and gateways. *Bridges* limit local traffic to within a LAN, but don't route packets to their destination networks, as routers do. *Gateways* are used to connect networks running different types of network protocols. Routers, bridges, and gateways are all invisible to users, who see an AppleTalk internet as a continuous network. Traffic-control devices will be covered in detail, later in the chapter.

How a network manager sees an internet depends on how efficiently it is set up. Some internets can be viewed as precision machines, predictable and efficient. Other internets are more like mystical clouds of incomprehension. This chapter's goal is to prevent the problems that can bring about the latter view. If you still feel a need to resort to incense and chanting, it's time to break out the tools for network maintenance and troubleshooting, which will be covered in Chapter 12.

Unless you want a dinosaur, you should never let an internet evolve by itself; it takes care, study, and planning. The location of computers, printers, file servers, and other network devices can make the difference between a fast, efficient network and a snailnet. Since it's harder to track down problems in a bigger and more complicated network, the design should be logical, architecturally simple, and easy to decipher. And, the network structure should be flexible; you should assume that there will be changes later on. Someday, you'll want to tweak the internet to solve problems and increase performance without disrupting the work of the organization.

Built In: AppleTalk Phase 2

AppleTalk Phase 2, the revamped version of Apple's network introduced in 1989, launched AppleTalk networking into the big time. Its need was apparent, particularly in large companies, where network managers were faced with integrating isolated groups of Macs into already large internets of PCs, workstations, and mainframes. AppleTalk Phase 2 rewrote half a dozen protocols and

added a new one to the Macintosh networking scheme, allowing networks to be smoothly connected together in large configurations. These internet-enabling protocols are built into the routers that connect networks. Phase 2 is also implemented on Macs in the form of Phase 2-compatible EtherTalk and TokenTalk drivers, which come with System 7, and in the ROM of later-model Macs.

Phase 2 permits an almost unlimited number of nodes to exist on an AppleTalk network. When LocalTalk was the only option, the old AppleTalk limit of 254 nodes was quite sufficient, since LocalTalk doesn't have the bandwidth to support anywhere near that number on one LAN. However, with the enhanced bandwidth capabilities of Ethernet, 254 nodes was unnecessarily limiting. AppleTalk Phase 2 raised the limit to over 16 million devices on Ethernet and token ring. Token ring became an AppleTalk option for the first time with the introduction of Phase 2. LocalTalk networks were not changed, and retained the old 254-node limit.

The new 16-million-node limit was achieved by raising the amount of possible ID numbers that a node could have. ID numbers (also called "addresses") uniquely identify a node to the other devices on the network. Previous to Phase 2 (and currently for LocalTalk networks), each Mac, printer, and other network device on a network was identified by a node number between 1 and 254 and a network number identifying the network to which the node belonged. Phase 2 allows for a *range* of network ID numbers to be assigned to a given network, so that different nodes within a network can have different network numbers that fall within that range (see Figure 6.1). Since this network number can be anywhere between 1 and 65,536 (or 2^{24} for a 24-bit binary number), the total number of possible ID numbers is 65,536 times 254 (the number of node numbers per network number), or 16,646,144. Clearly this is enough for any local area network.

Figure 6.1

AppleTalk Phase 2 lets you assign a network number or a range of numbers for a single LAN. Nodes also assign themselves a node number, unique for a given network number.

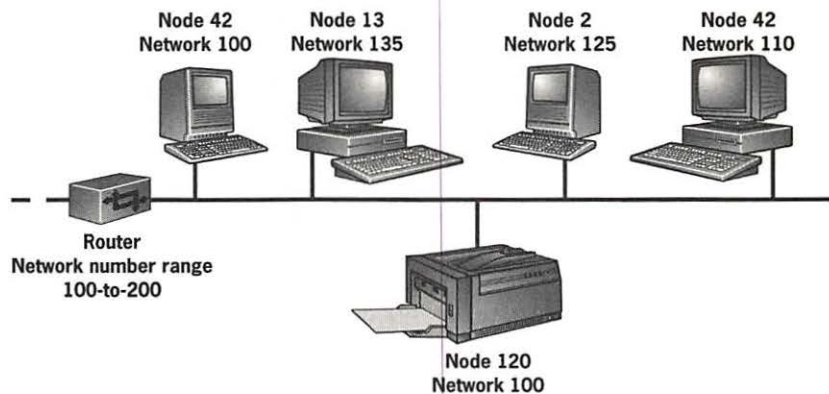

Even if the original AppleTalk could have supported the network ID numbers allowed in Phase 2, it would have quickly bogged down in network traffic. AppleTalk Phase 2 reduced traffic with several methods that prevented routers from broadcasting redundant information over the internet.

Phase 2 also made it easier for users to locate network devices on a large internet by allowing the creation of up to 256 zones in each Ethernet and token ring network. *Zones* are logical groupings of nodes that show up in the Chooser (see Figure 6.2). With network resources organized by zone, a user looking for a printer doesn't have to search through a list of all the printers on the internet, which could number in the dozens or hundreds. Zones are set up by a network administrator when configuring a router. LocalTalk can only have one zone per LAN, which is not a limitation, given the inherent small size of LocalTalk networks.

Figure 6.2

Zones are used to divide up network resources into logical groupings.

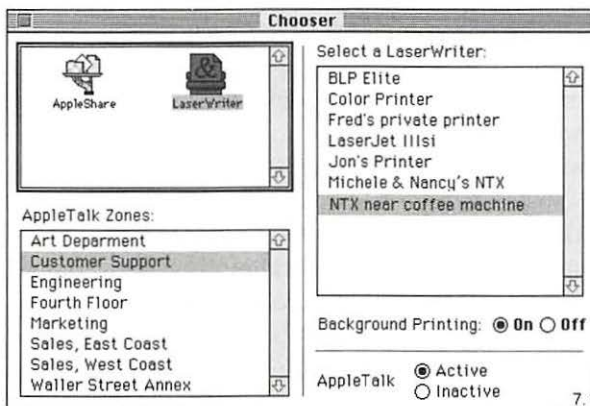

■ Using Internet Building Blocks

When does a bunch of individual networks become an internet? When the individual LANs are connected with a bridge, router, or gateway. Routers are the most commonly used traffic-control devices in AppleTalk internets because of their ability to send packets through the shortest route to their destination. Routers and gateways can be used to connect networks with different data link mechanisms, such as LocalTalk and token ring. Bridges usually connect two Ethernet networks, but are not common in AppleTalk networks. LocalTalk does not support bridges. LocalTalk, Ethernet, token ring, and ARCnet all support both routers and gateways.

Routers and gateways are nodes on the internet—intelligent devices with ID numbers. Bridges and hubs, discussed in the last chapter, are not nodes, and are completely invisible to the internet. Some routers include built-in bridging and gateway functionality in addition to their basic routing functions. Some routers and gateways are used to connect physically separated LANs in wide-area networks.

If you connect two LANs together with a wire, you wouldn't get an internet—you'd get a bigger LAN, increasing network traffic and possibly running into node limitations. Bridges, routers, and gateways share the ability to distinguish between packets that are addressed to a node within a network and packets that have destinations outside the individual LAN. Packets that have local destinations are prevented from being transmitted to networks where they have no business being. Packets with addresses outside the local area network are allowed to pass. Each of the three types of devices handles this in a different way.

Bridges

A bridge looks at a packet's destination node address and compares it to its stored table of node addresses. This table is created and updated by the bridge through the use of periodic broadcast inquiries and the recording of responses from the nodes. This procedure produces a rather limited worldview for a bridge, shown in Figure 6.3. No matter how big an internet is, the bridge sees it as a network of nodes in two parts, one connected to either of the bridge's ports. A bridge can't see other bridges or routers, and therefore doesn't distinguish between networks. When a bridge receives broadcasted messages, it looks only at the destination node address, then looks up on its table to see on which side of the bridge the destination node lies.

Routers

A router, on the other hand, looks at a packet's destination *network* address, not its node address. It keeps a table containing zone names, network numbers, and routers and their locations relative to itself. A router can also have more than two ports. As Figure 6.3 shows, a router's worldview is one of multiple, nodeless networks on an internet of routers. This viewpoint enables a router to find the shortest route through an internet to send a packet to its destination network. This is the main reason to use a router in an internet. Routers talk to each other to update their routing tables, whereas bridges work in isolation.

Figure 6.3

A message has been sent to Node Z on Network 8. A bridge only sees that the packet's destination is on the other side. A router sees the destination network and sends the packet through the shortest route.

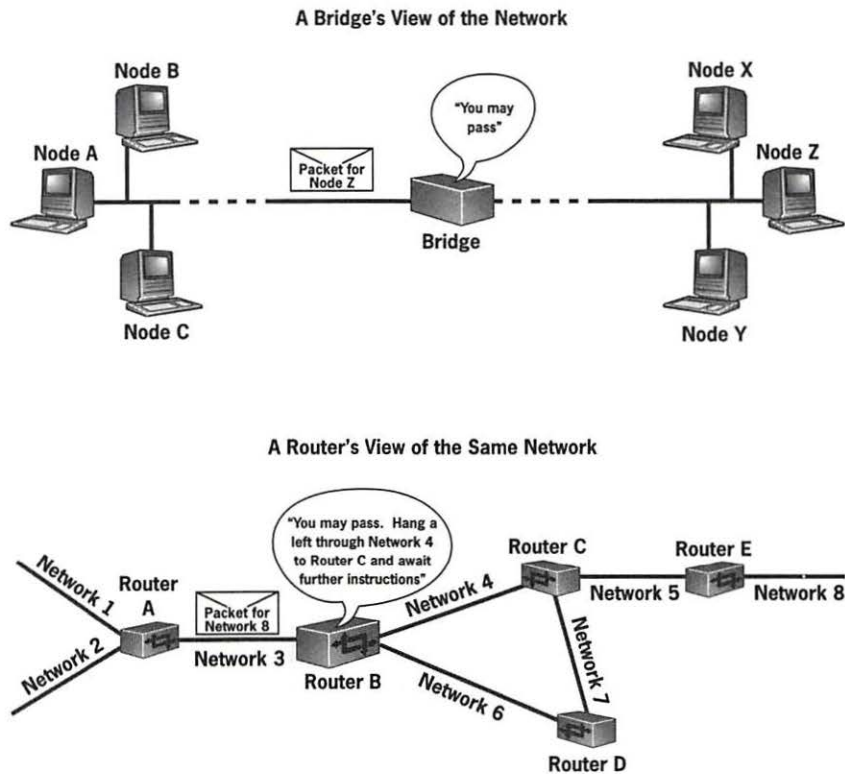

Routers have been replacing bridges during the past few years, especially in large internets. However, there is still a role for bridges in isolating traffic on an internet. Bridges are very easy to install and set up, and require less maintenance than routers. Using some bridges in place of a few routers on a large internet can also reduce network traffic, because bridges don't send out as much query and update information as routers do. And because bridges look at addresses of individual nodes, they can often collect statistics on errors and traffic, which are useful in troubleshooting and fine-tuning an internet.

Gateways

A gateway connects a pair of disparate LANs that use noncompatible sets of networking protocols, usually running on different types of computers. In Chapter 2, I described some gateways to foreign PC LANs (Miramar's Mac-LAN Connect, for example). Also available are gateways that connect AppleTalk with TCP/IP, used by UNIX workstations; DECnet, used by Digital Equipment's VAX minicomputers; or SNA, used in IBM mainframes.

Gateways are available as stand-alone boxes or as software running on Macs, PCs, VAX minicomputers, or UNIX workstations. Both types of gateways often accept add-in software modules for translating network services such as file and printer sharing and electronic mail. Unlike bridges, which just repeat the contents of a packet when they pass the packet through, and routers, which add address information to guide packets through an internet, gateways for network services actually alter the contents of network packets, translating them into a form that can be read by network applications on the other side. This means that each network sees file serving in its native format, AFP for AppleTalk and NFS for UNIX, resulting in a familiar interface for users on both networks.

■ Planning an Internet

Like historic Italian cities, internets aren't built in a day. They take planning. There is no reason to believe that merely connecting existing LANs together will result in the best network speed possible for every user—you could instead get poor performance for everyone. The placement of users' computers, network resources, and routers is a key factor in creating smooth-running internets. Before you make any connections, study the way your current network works. Look at users' habits, and determine who uses what peripherals and when. Make sketches of various possible network setups and think through how different users would work with the new setups. Internet design is a science, and users tolerate the theoretical approach much more than the experimental.

Also, don't think small; allow for future expansion, so that adding new users and peripherals will not require major disruptions in people's work or total redesign of the internet. The internet should also accommodate the addition of new LANs and the division of current ones. Assume that there will be upgrades made to users' Macs, printers, file servers, and even routers.

In addition, allow for technological expansion. As computer hardware continues to get faster and software becomes bigger and more powerful, more data gets pumped over networks. Many users are working with and printing gray-scale and color files. Increasing numbers of applications are implementing System 7's features for automatic application linking, interapplication communications, and Apple events, which more and more users will be working with over networks. Where once 50k PICT files were passed around networks, TIFF files measuring many megabytes are now common. Even bigger are video and animation files, made practical by Apple's Quicktime. In addition, new applications for networks are born every two years or so, adding even more traffic. This doesn't mean you have to have the capability to handle all this potential traffic now, but you should be able to upgrade when needed.

Network Traffic

A major factor to consider in internet design is where and how network traffic is generated. Although the size of individual packets sent over a network can vary, it is the number of packets being sent over the cables that is the measure of network traffic. As with freeways, too much traffic in one spot can back up traffic and bring sections of the internet to a crawl. Unlike traffic on a freeway, heavy traffic on a broadcast/collision type network (LocalTalk and Ethernet) generates even more traffic, because packets are re-sent when packet collisions occur (see Chapter 5).

Users create most of the network traffic with their network activities. Electronic mail and printing of text documents generate a fairly low amount of traffic, but printing graphics files can cause moderate to high traffic. Transferring files of any type generally causes more traffic than printing does, especially for large files. Accessing multiuser databases is a moderate traffic generator. Running applications from a server is a very high traffic generator, because of the constant communication between the application on the server and your Mac's CPU. For this reason, I recommend against keeping ordinary (non-network) business applications on a server.

Users can also create traffic without realizing it. For instance, network traffic is created when users open the Chooser and select a driver. When the LaserWriter (or any other network) driver is selected, the Chooser goes out and asks available printers to send in their names so that the Chooser can list them. This information is periodically updated as long as the Chooser is open; so to avoid creating unnecessary network traffic, it is a good practice for users to close the Chooser after making a selection.

Starting up a Mac also creates network traffic: The Mac asks the other nodes on the LAN if the node number it has chosen is unique. This feature of AppleTalk, called dynamic node addressing (described in Chapter 4), eliminates the need for network managers to assign node addresses to Macs and printers. Because the start-up process creates network traffic, users should leave their Macs and printers on during the day.

Another type of traffic, called overhead traffic, is generated automatically by network devices. Routers broadcast messages every ten seconds or so to enable the other routers to update their routing tables. Electronic mail servers send out message alerts to let users know when they have a message waiting. File servers that are mounted on users' hard disks will update periodically. For this reason, users should not automatically mount servers at start-up, but sign onto them only when they need them, and then disconnect.

To prevent bottlenecks, you'll need to spread out network traffic evenly across the internet. I'll discuss how to monitor network traffic in Chapter 12, but you can predict where heavy traffic loads will occur by considering the location of the network nodes.

Arranging Network Nodes

When deciding how to arrange computers, printers, and routers in an internet, there are two facts to keep in mind: Routers and bridges prevent local traffic from being broadcast to other LANs, and crossing a router slows down the network transaction. Thus, it would be a bad idea to concentrate all the internet's printers on a single LAN, because all users outside that LAN will have to cross routers to get to the printers, and a lot of traffic would be going through that one network. Instead, it is best to spread network resources evenly throughout the internet.

Creating Workgroups

Computers, printers, and file servers are best arranged in workgroups that don't extend beyond a single network. A workgroup is a group of users who share the same network resources on a day-to-day basis. Each workgroup LAN should include as many of the network services required by users as possible (see Figure 6.4). Crossing a router puts unnecessary traffic on another network. Each workgroup should have at least one printer, and possibly its own file server as well.

Figure 6.4

An inefficient internet setup has users accessing other LANs for frequently used services. This internet can be fixed by installing a printer in Network A and a network modem in Network B.

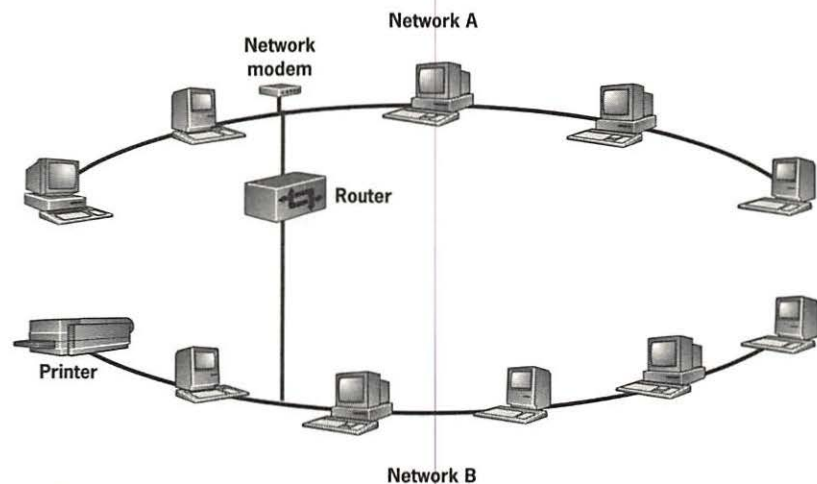

Keep in mind that network resources don't have to be physically located in the workgroup. With the appropriate wiring setup, you can keep the file servers, network modems, and other devices belonging to various networks all together in a single locked room where they can't be tampered with.

You may also benefit from dividing up a larger network into separate networks. For instance, a LocalTalk network approaching 30 nodes is near its

practical node limit and may experience slow performance. Dividing it in half with a router should result in an immediate network performance boost for everyone. However, if everyone in the network needed to access the same network services, such as a color printer, you'd have an undesirable situation: Users from the newly formed network would be continually crossing the router and creating traffic on the old network.

A better alternative than dividing the LocalTalk network in half would be to keep it as a single LAN, but upgrade all the nodes to Ethernet. This would increase the network bandwidth and raise the limit for the number of nodes capable of existing on one LAN.

A third alternative would be to split the network into two, and buy another set of network services for the new workgroup. Which of the latter two alternatives would be better depends partly on the results of a cost analysis: Is it cheaper to buy a new color printer and a router or upgrade everyone to Ethernet?

Cost, however, is not the sole consideration. Another reason to divide a network is to isolate heavy traffic-generating workgroups. People who print large graphics files or who frequently access databases cause heavy traffic to be broadcast all over the network, slowing down network performance for everyone within the network boundaries. For this reason, workgroups doing high-end desktop publishing or electronic prepress should always be isolated on their own Ethernet LAN. A separate Ethernet network of these power users could be created from a LocalTalk network by the addition of a LocalTalk-to-Ethernet router.

Placing Routers

In the last chapter, we saw that the design of a network can be discussed in terms of its topology. Internets also can be described by topologies, but at a higher level of organization than networks. Instead of considering the arrangement of individual nodes in relation to each other, internet topology describes the relation of whole networks to each other. An internet's topology (and to a great degree, its efficiency) is determined by where the routers are located.

A major goal in designing an internet's topology is to minimize the number of hops that network signals need to travel. A *hop* is a measure of distance defined as "one network away." Since networks are connected by routers, a packet traveling one hop will pass through one router. The user in Figure 6.5 is communicating through three hops to access the mainframe database.

Going through a router slows down communications; therefore, the more hops a packet has to travel, the longer it will take to get to its destination. Hops usually can't be avoided, even when you have designed workgroups to prevent users from needing to go outside a LAN, as described in the previous section. Users may need to access a centralized database located in another network, and often need to send electronic mail messages to users on other LANs.

Figure 6.5

This Mac and the mainframe database server are communicating at a distance of three hops.

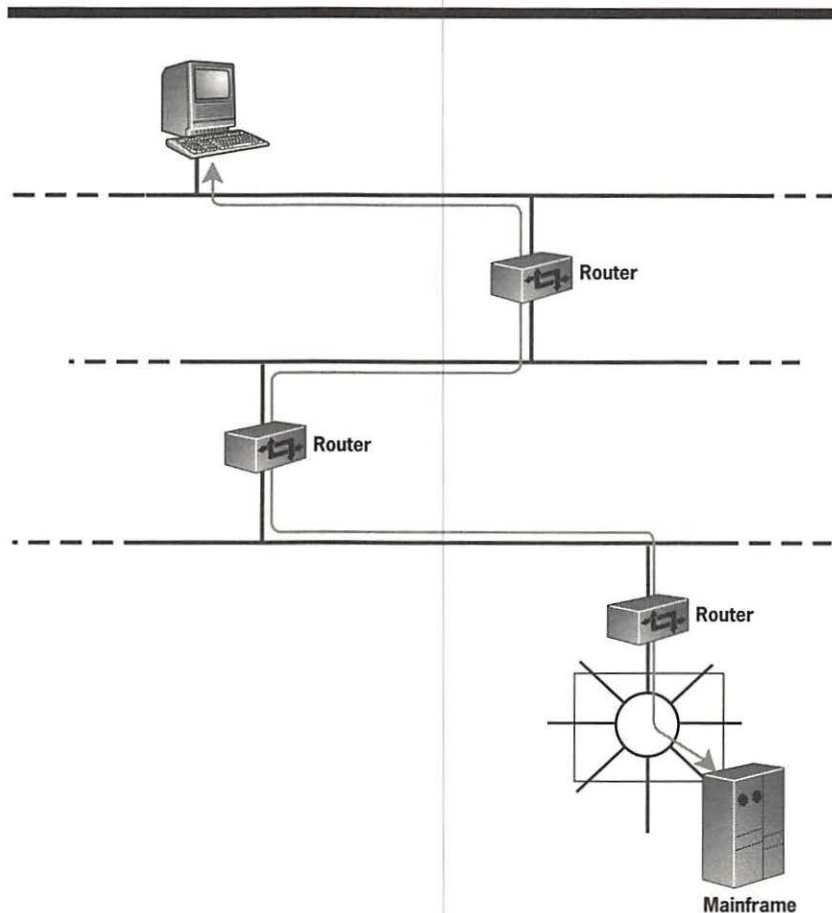

Although the maximum number of hops allowed in AppleTalk is 15, there is a rule of thumb that says that no user should have to send a packet over a distance of more than 4 hops to accomplish a task. Traveling longer distances slows down transactions beyond a comfortable level and sends unnecessary traffic through too many LANs. One way to guarantee compliance with the four-hop rule is to use a backbone topology, first described at the end of Chapter 5.

The main benefit of a backbone is that it reduces the maximum number of hops between any two nodes on the internet to two, as shown in Figure 6.6. A backbone is an efficient way to connect LANs located on different floors or in separate buildings. In addition, a backbone is usually one of the fastest routes in the internet, usually consisting of an Ethernet or token ring (and soon FDDI) data link mechanism on high-bandwidth cable. A packet traveling two hops through a high-speed Ethernet network will get to its destination

faster than a packet traveling two hops through a LocalTalk network. LocalTalk should not be used in a backbone.

Figure 6.6

The distance between any two nodes on different networks directly connected to a backbone is always two hops.

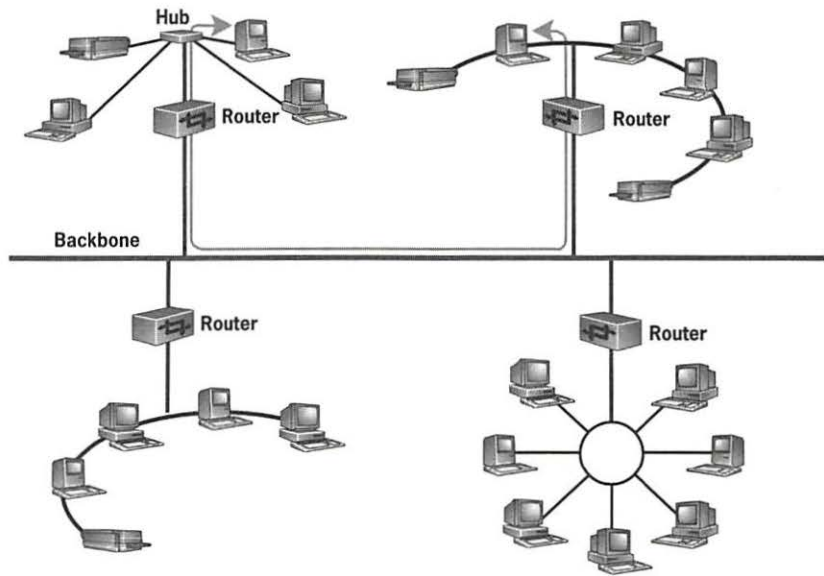

Backbones don't usually have users' computers directly connected to them, but a backbone can directly support shared peripherals that many people on the internet need to use (see Figure 6.7). Although each network should have its own printer, in every workgroup, there are some network devices that can't be reproduced. These include expensive devices, such as a high-quality color printer, or unique resources, such as a file server containing data everyone needs. However, since all inter-LAN communication goes through a backbone, it will carry a good deal of internet traffic. It's therefore a good idea to keep to a minimum the number of devices directly connected to the backbone.

The downside to a backbone topology is that there is also a minimum of two hops required to communicate between any two networks. For internets consisting of a handful of small LANs, it may make sense to not use a backbone, but to daisy-chain the networks instead. Another option is to use a single multiport router in a star-shaped internet. A star internet gives you a maximum of one hop between any two networks. It's also the most economical method for configuring an internet, since you need only one router.

Figure 6.7

Network devices connected directly to a backbone create a lot of traffic, and should, therefore, be limited to expensive or unique services that users in many LANs need.

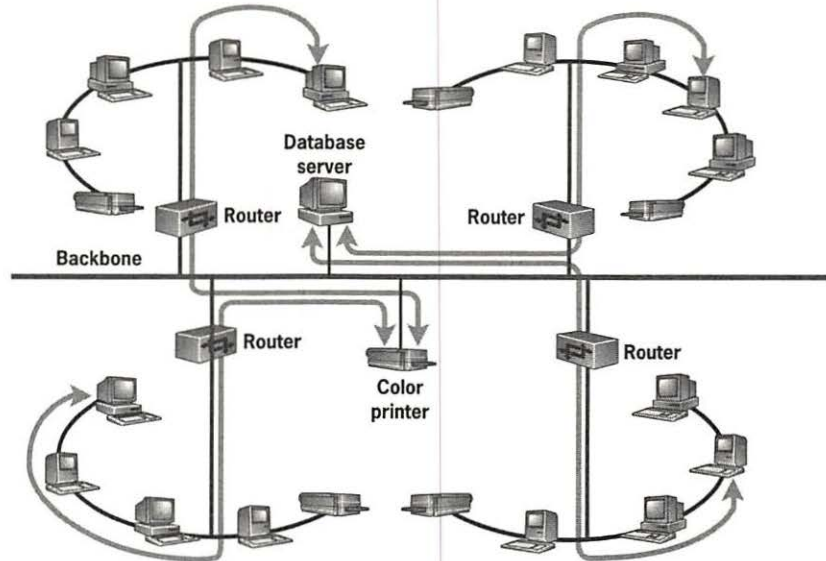

Another strategy to reduce hops is to create an internet that has more than one path between networks, as shown in Figure 6.8. This is sometimes called *redundant routing*, which is also a good way to keep an internet together when a router fails or a cable breaks. Routers in such a setup will pick the route with the fewest number of hops to send a packet. Troubleshooting can be made more difficult, however, in situations where there is the same number of hops between two alternative routes, because network management software may confuse the two paths.

Creating Zones

Dividing a network into zones is done purely for reasons of convenience. Zones make it easier for users to locate network devices in the Chooser. Creating zones is especially important with large networks; if there was only one zone for the entire internet, users would have to scroll through a Chooser list of dozens or hundreds of devices just to pick a printer. Zones can also be created to organize nodes by function, or to organize members of a workgroup under a single name, both of which help users physically locate the devices. Zone names like “Accounting,” “Engineering,” “Fourth Floor,” or “West Wing” are very useful.

Figure 6.8

Some examples of redundant routing, which can keep the internet together in case of the failure of a router or cable and can offer shorter routes between some networks

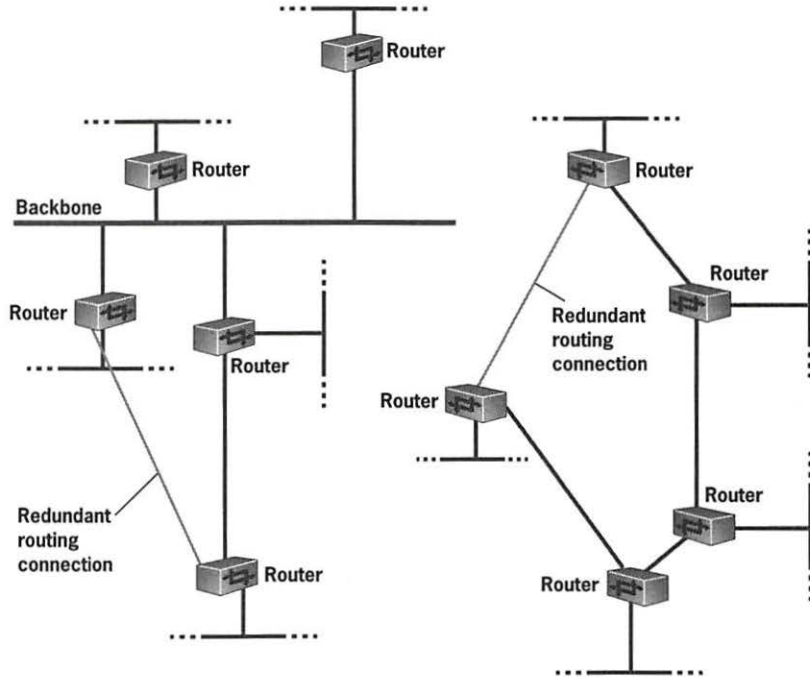

AppleTalk Phase 2 allows up to 256 zones in an Ethernet or token ring network. There is no restriction on the size of a zone, which can consist of one Mac or the entire internet. Zones are logical groupings of nodes: They don't have to have anything to do with where nodes are located physically on an internet. A single zone can accommodate users in several networks, which might be useful in creating a workgroup of users who are physically separated or in different networks. Keep in mind, however, that users can't tell when they are crossing routers to access network devices, so that creating multinet-work zones could create unnecessary traffic on multiple networks.

You create zones when you set up an AppleTalk router. If you are setting up multiple zones within one network, you'll have to set up a network zone list for the LAN and signify a default zone for each network device. The default zone is the zone that is automatically selected when a user brings up the Chooser. When a Chooser driver such as AppleShare or LaserWriter is selected, the Mac polls the internet for the device type (such as file servers or printers) belonging to the zone selected in the Chooser.

■ Choosing a Router

With your internet design (or redesign) well under way, you can start to shop for a router. You can't kick the tires before you buy a router, but there are some questions you can ask your dealer. The selection of AppleTalk routers is large enough for you to be particular, so don't settle for a router that requires you to alter your internet. The router should fit your network, not the other way around.

Routers come in all sizes and prices, from small boxes to add-in cards for big concentrators. Some are software-only packages that run on a Mac. There are lots of different things routers can do in addition to basic routing. Routers can come with dial-in, hub, bridge, and gateway functionality, as well as other plug-in functions.

Router Features

One task routers do is connect networks with different data link mechanisms and cabling schemes. AppleTalk routers are available with two to eight ports, several of which are usually LocalTalk. Ethernet is almost universally supported, though some routers also support token ring. It's a good idea to buy a router with Ethernet or even token ring ports for future expansion, even if you have only LocalTalk networks at the moment. Most AppleTalk routers support Phase 2, as well as mixed Phase 1 and 2 internets.

Some routers have high-powered RISC (reduced instruction set) processors, but the extra computational power usually goes toward handling extra functions or more ports rather than making routers significantly faster. MacUser Labs testing has found slight differences in speed between various routers, but not enough on which to base a buying decision.

Some routers can also collect information on traffic and errors, which is useful for troubleshooting or fine-tuning the internet design. An up-and-coming feature is support for SNMP (simple network management protocol) for monitoring network traffic and performance. SNMP will be discussed in Chapter 12 along with other network management issues.

Another feature to look for is the ability to hide zones, printers, or other network resources from certain users or workgroups. This feature, sometimes called resource filtering, can be used as an extra layer of security for a file server or to create an invisible confidential zone for a sensitive workgroup, such as a Research and Development group. Resource filtering can also be used to prevent just anyone from using an expensive resource such as a high-quality color printer that costs several dollars per printout. Hiding certain zones or network resources can also be a convenience for users on large networks because it reduces the size of zone and resource lists in the Chooser.

Reliability is an important factor that is hard to determine beforehand, but you can ask a vendor how the router works when problems occur. For instance, ask what happens to a vendor's router when it is swamped with heavy traffic or *storms* (error conditions in which routers are propagating volumes of useless network traffic). Ideally, you want the router to have the least amount of impact on users. For instance, the Cayman GatorBox has a "fair share" algorithm which uniformly slows performance for everyone slightly, instead of letting one segment of the network come to a grinding halt. Alternatively, some routers will randomly drop users, who will have to relog onto network services. That is, some routers will ignore packets from a particular user so that nothing else on the network sees them.

You can also ask your vendor what happens to the router after a power failure. The best routers are those that automatically go on-line with routing tables intact when the power returns. The worst routers are those that completely lose the configuration information when power is gone. The internet could be out of commission for quite some time if you had a dozen routers of the latter type to reconfigure after each power failure.

Don't forget to ask a router vendor what type of technical support is offered. Internet problems are not always the fault of routers, but routers are often the cause of some of the more mysterious errors. It is helpful to have some guidance from a router vendor's tech-support department when you run into internet problems that you can't diagnose.

Routing on Your Mac

There are two software routers that run on a Macintosh, Apple's AppleTalk Internet Router and Farallon's Liaison. Liaison has more features, such as dial-up access and the ability to hide zones. Software routers can be purchased for one-tenth the cost of hardware routers, not counting the cost of a Mac to run it on. You don't need a dedicated Mac; you can run a file, print, or mail serve on top of it. However, you'll want to use a dedicated Mac for situations with heavy network traffic, or a hardware router. Software routers are easy to set up, and the administration software is easy to use, putting routing table information at your fingertips (see Figure 6.9).

Software routers generally support more networks than do hardware routers, with a maximum of eight: The Mac's printer and modem ports can both be used for LocalTalk networks, and you can fill a six-slot Mac with network interface cards. Both Apple and Farallon software routers support Ethernet and token ring, and Liaison supports ARCnet as well. The ability to add any network interface card makes software routers flexible. A Mac running router software that is configured for 10BaseT Ethernet and token ring can be changed to include coaxial Ethernet and LocalTalk networks in just a few minutes. This feature is not unique to software routers, however. Some

of the larger, more expensive routers also have the ability to add plug-in modules for different configurations. NRC offers add-in cards for wide-area networking with some of its routers.

Figure 6.9

The AppleTalk Internet Router displays a routing table on the screen.

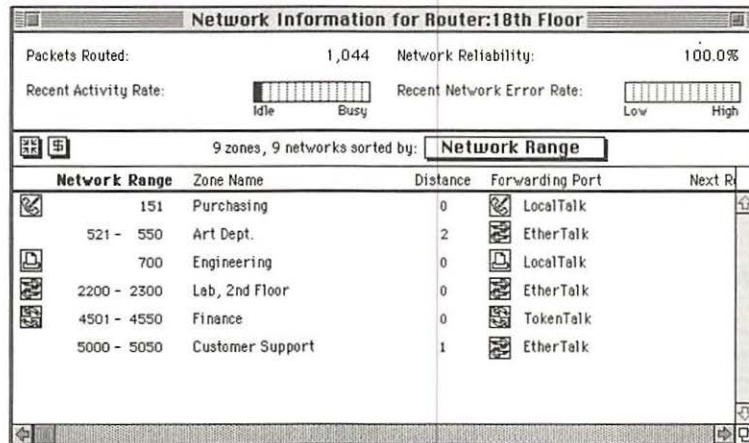

There is a danger with routers that run on a Macintosh. If the System or hard disk crashes (and Macintoshes have been known to crash now and then), the network's connection with the internet goes down with it. For this reason, you should never run a software router on a Mac being used as a workstation.

Routing on a PC

PC network operating systems, such as Novell NetWare and Banyan VINES, often offer optional router software that runs on the PC server. These options can contain advanced features, such as telephone access, resource filtering, and multiprotocol routing (discussed below).

The biggest problem with this type of all-in-one approach is organizational: It puts local and company-wide resources in one box, each of which can fall under the jurisdiction of a separate manager. Since routers can propagate errors across an entire internet, large companies with internets containing dozens or hundreds of routers usually have a central organization to handle internet plumbing problems. File servers, on the other hand, are often controlled at the workgroup level by a manager who doesn't want the central authorities interfering with the services vital to local users. Both local and central authorities have equally valid concerns, so the best solution in a case such as this is to not use the router software on the file server.

Half-Routers: Routing by Phone

A half-router performs the routing function through one port only, and merely receives or passes data straight through the other port(s). Full-routing capability is obtained only when two half-routers communicate with each other.

Some half-routers, such as Shiva's Netmodem/E, are used to connect two LANs over the phone lines. Each router can have a built-in modem or can be connected to one (see Figure 6.10). Shiva's Netmodem/E works on Ethernet networks of both Macs and PCs. The Netmodem/E can route both AppleTalk and Novell's IPX protocol, allowing Macs to dial into networks running Novell for Macintosh. Similarly, PCs can dial into AppleTalk networks and access AppleShare servers, provided they are running software such as Farallon's PhoneNET Talk, discussed in Chapter 2.

Figure 6.10

Half-routers can be used to join two networks over a modem line.

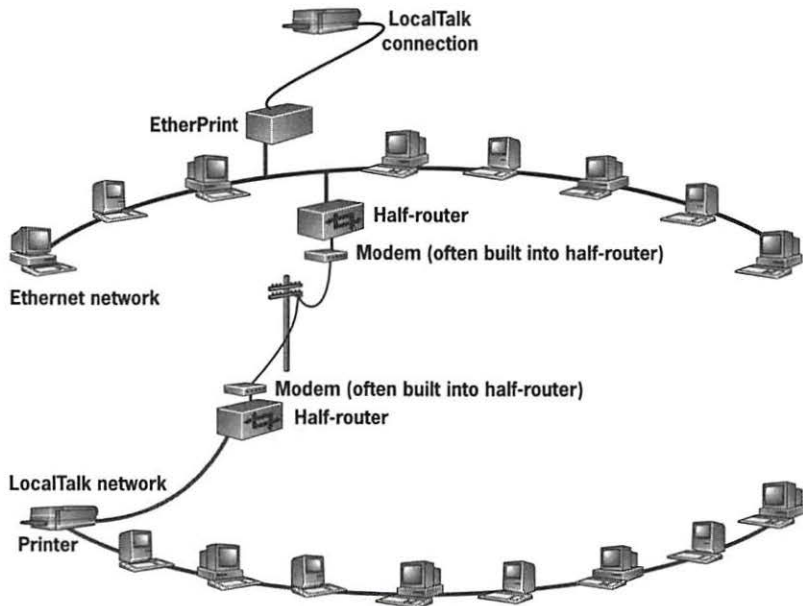

Another alternative to full-routers is devices that connect a LocalTalk printer to an Ethernet network, such as Dayna's EtherPrint. Although they may appear to be similar to half-routers in function, they don't use routing protocols at all. Some of these devices can support up to four LocalTalk printers—a much cheaper solution for putting LocalTalk printers on Ethernet than using a full-router.

Routing Non-AppleTalk Protocols

Some routers can run foreign network protocols, such as TCP/IP and DECnet, alongside of AppleTalk protocols on the same network. This is important if you have nodes running applications that require these protocols for communicating with other types of computers on the internet. Each protocol requires a separate routing table, in addition to the AppleTalk routing tables, thus creating more network traffic.

There are two ways to route non-AppleTalk protocols: by running the protocols straight over the cables or by using a technique known as *encapsulation*, a process that puts a packet of one protocol type inside one of another protocol type. You can run actual TCP/IP and DECnet protocols alongside of AppleTalk on Ethernet and token ring networks. LocalTalk is not a multiprotocol data link, so you must encapsulate foreign network protocols inside AppleTalk if you want a LocalTalk Mac to receive foreign packets.

Encapsulation puts a TCP/IP or DECnet packet inside an AppleTalk packet, so that the packet appears and is handled by the network as an ordinary AppleTalk packet (see Figure 6.11). The inside foreign packet is ignored by most network processes, but understood by the application running on the computer receiving the data. Whether you need to route straight packets or use encapsulation depends on what the user node or application requires. In general, Macs can make use of either technique, but encapsulation results in less network traffic. Not all routers use both methods, so be sure to find out from the manufacturer if your application requires one or the other.

You can also do this in reverse and encapsulate AppleTalk packets inside foreign packets. This is particularly useful with TCP/IP. Some organizations with large mixed networks use TCP/IP as their backbone because it generates much less overhead traffic than AppleTalk. TCP/IP is suitable for very large networks on the scale of 100,000 nodes extending over a wide area. Encapsulation of AppleTalk packets is used when passing messages between two AppleTalk networks over a TCP/IP backbone, as shown in Figure 6.12.

A wide-area networking routing feature called *tunneling* uses the technique of encapsulation to connect AppleTalk networks separated by long distances through very large TCP/IP networks called *IP clouds*. There are several ways to accomplish this. It should be noted that encapsulation and tunneling are not interchangeable terms; routers that support encapsulation do not necessarily support tunneling.

Figure 6.11

Encapsulating a foreign network packet inside an AppleTalk packet enables the data to be handled by ordinary AppleTalk network processes.

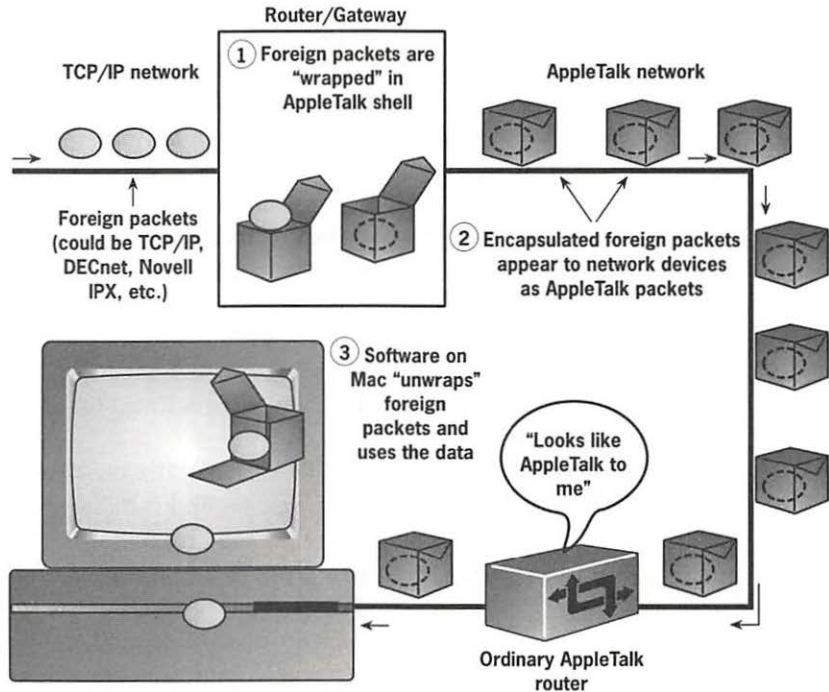

■ Installing a Router

The experience of installing and setting up a router can vary from being a simple procedure to resembling a crash course in quantum electrodynamics. If you haven't had much experience in setting up a router, ask the router vendor if you can take a look at a manual before your purchase.

The installation procedure entails both hardware and software. The hardware setup includes connecting cables and setting jumpers on the router for the particular types of cables you are using. Some routers make this easier by providing simple switches on the outside of the box instead of internal jumpers. Others let you set the cable type in software.

Installing router software is the biggest job, in which you provide network numbers (addresses) for the individual LANs on the internet. You'll want a router that enables you to configure the software from a Mac.

Figure 6.12

Encapsulating AppleTalk inside of TCP/IP enables two AppleTalk networks to communicate over a TCP/IP backbone.

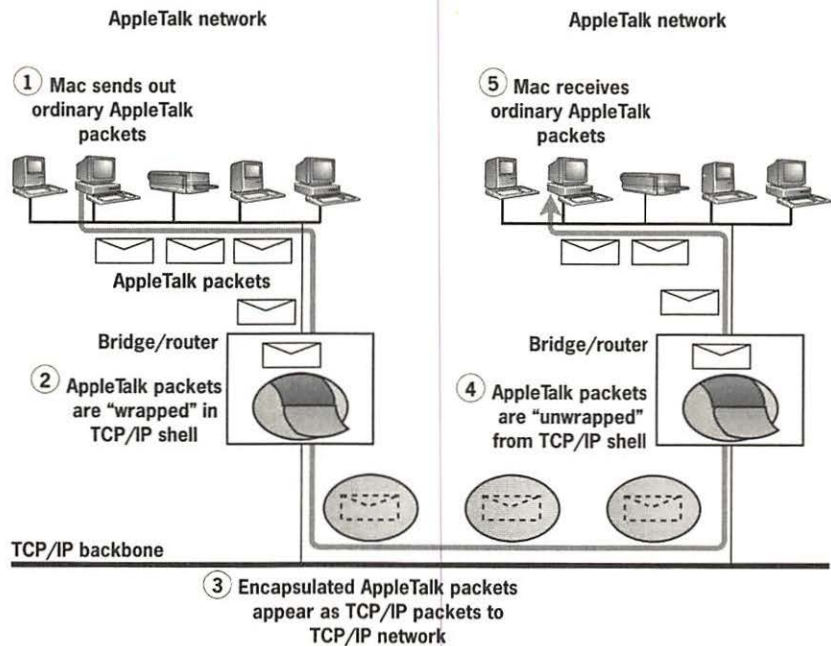

Assigning Network Numbers

How you number your networks is important for network growth. Remember, AppleTalk Phase 2 allows for 254 devices per network number, and you have 65,536 network numbers from which to choose. Although LocalTalk is limited to one network number per network, Ethernet and token ring can be assigned a range of network numbers.

You can assign numbers randomly, but it makes sense to use some sort of numbering scheme that can give you information about the networks. For future troubleshooting purposes, you might want to use some sort of code to let you know the location or type of network. For instance, you could assign the first digit to represent a site (for example, 1=head office in New York, 2=San Francisco division, 3=sales office in Boston, etc.). The next digit could indicate the building or floor, the next the department, and another digit could be used to indicate something about the network itself. The last two or three digits could be used for the range of the network numbers used for your Phase 2 network. Putting it all together, if you saw a certain number

between 234501 and 234515 on a routing table, that would immediately tell you, for example, that you were looking at the Ethernet network segment used by those troublemakers in accounting on the third floor of the San Francisco office.

Upgrading to AppleTalk Phase 2

Most routers sold today are AppleTalk Phase 2 compatible. If you have an older AppleTalk Phase 1 network and haven't upgraded yet, it's time. Phase 2 has proven to be solid—most larger companies use Phase 2 at this point. Upgrading Macs is simple: No upgrade is required for LocalTalk or TokenTalk. TokenTalk was introduced with Phase 2, so there are no Phase 1 TokenTalk drivers. Laser printers that have Phase 1 in ROM also work on Phase 2 networks.

Macs on Ethernet require EtherTalk driver version 2.0 or later. During the transition, you may have a network with some Macs using Phase 1 EtherTalk drivers, and some with the new drivers. These Macs won't be able to communicate with each other unless your router supports both versions. Even if your router does support this mixed condition, you should treat it as a temporary transitional setup only, and move to Phase 2 drivers as soon as possible.

Routers in a Phase 2 network must be Phase 2 compatible. For older routers, the manufacturer probably has a Phase 2 upgrade for the router software. If not, you'll have to replace the router with a Phase 2 compatible model. Because of the differences in network numbering schemes, you can't just upgrade routers one at a time and still have a functioning internet. Phase 1 and Phase 2 routers won't be able to communicate with each other, and will confuse other network devices.

There are three strategies for upgrading your routers. You can upgrade all of them at one time, producing some internet downtime. This is the quickest way to convert completely to Phase 2, but it becomes more difficult with increasing numbers of routers. The second strategy is to upgrade incrementally, disconnecting the new Phase 2 networks from the Phase 1 internet, and gradually building a complete Phase 2 internet. This strategy takes longer than the first, but retains at least partial connectivity between networks.

The third method is to install an AppleTalk Internet Router on a Mac running Apple's AppleTalk Phase 2 Upgrade Utility. The utility lets you mix Phase 1 and Phase 2 routers on an internet for a limited time. There are hardware routers available that support transitional mixed networks, as well. There is a catch—you can't use any of the extended addressing features of Phase 2 until every router is upgraded. You then have to go back to each router and reassign network numbers to take advantage of Phase 2.

■ Looking Ahead

Starting with small networks in Chapter 5 and ending with huge internets in this chapter, I've so far been discussing the infrastructure of AppleTalk networks. But few people appreciate routers for routers' sake. The next chapter will explore the reasons why we create networks in the first place: the network services. The things you can do with Macs on AppleTalk networks apply to networks of any size.

- *Built In: File and Print Services*
 - *Using Apple's Network Services*
 - *Using Third-Party Mac Services*
 - *Using the Mac as a Server Platform*
 - *Outgrowing a Mac Server*
-

CHAPTER

7

Network Services



ALTHOUGH YOU CAN GET A MOUSE AND A WINDOW ON almost any computer, the Mac still holds one unique advantage—network services for the rest of us. Network services on a Mac facilitate your work, enabling you to concentrate on the task at hand instead of on how to use the network. Because no other personal computer integrates network services, operating system, and graphics interface as tightly as does the Macintosh, installing and using network services is simpler for the Mac than for other computers.

The original Mac network service provided the ability to share a LaserWriter on a LocalTalk network. Turning the laser printer into a node on a network decentralized and greatly simplified shared printing. The result was plug-and-play printing, a concept that is still rarely encountered in the DOS world.

The introduction of the AppleTalk Filing Protocol (AFP) and the AppleShare file server in 1987 was probably the single most significant event to date for Macintosh network services. Although the ability to share files over a network was previously available with products such as TOPS, AFP enabled users to communicate with file servers using the same methods for accessing files on a Mac hard disk. If you know how to use the Finder, you know how to use a file server, regardless of whether the server is a Mac, PC, or VAX.

With the two basic network services in place, Mac networks began to proliferate, and third-party developers brought out new services. Print sharing was augmented by print *spooling*, a process that frees up your Mac by queuing print jobs and feeding them to a printer one at a time. (Spooling has nothing to do with a thread; it's a rather contrived acronym for "simultaneous peripheral operations on line.") Along with file sharing, print spooling is now part of the Mac operating system. Recently, electronic mail and database services have become common add-ons to AppleTalk networks, and new services such as group calendars and workgroup computing are just now proving their usefulness.

This chapter looks first at the various types of network services that come with your Mac, as well as at add-on services you can buy from Apple and third-party vendors. Following this discussion is a review of the types of computers you can choose as server platforms.

Built In: File and Print Services

Right out of the box, the Mac comes with two basic network service capabilities: the ability to print and spool to shared printers, and the ability to share files through accessing and producing AFP-compatible shared volumes. In the System Folder, there are five basic system extensions that provide these services:





Chooser. Used to select network services



LaserWriter Chooser extension. Provides ability to connect to most AppleTalk laser printers through the Chooser



PrintMonitor. Spools multiple print jobs from your Mac and displays a list

-  AppleShare Chooser extension. Provides ability to connect to any AFP-compatible server volume through the Chooser
-  File Sharing (System 7 or later). Provides ability to turn parts of your hard disk into sharable volumes available to others

Network services start at the Chooser, which is where you go to log onto servers and select print services (see Figure 7.1). Just as you click on the LaserWriter icon to get a list of networked laser printers, clicking on the AppleShare icon brings up a list of shared volumes. You can add third-party network services as well, so that clicking on a mail icon would get you a list of mail servers. (The Chooser drivers that come with your Mac are generic—they can be used with file servers and printers from many vendors. Third-party drivers that you add are specific to one product.) Most services can be set to automatically log on when you boot up your Mac. A few products don't use the Chooser to log on (CE Software's QuickMail uses an Apple Menu item, for example), but these are in the minority. There is no limit to the number of services you can add to the Chooser.

Figure 7.1

Each Chooser icon represents a network service. The AppleShare and LaserWriter drivers come with the Mac; others such as electronic mail and group scheduling can be added.

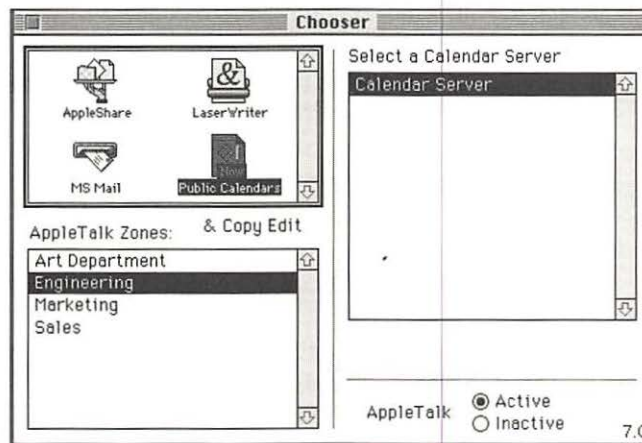

The PrintMonitor extension is a background printing program that runs automatically whenever you print. It allows you to continue working in an application while the Mac sends one or more print jobs to a printer. The printer can be a networked printer or a local printer connected to your Mac with a serial cable. PrintMonitor displays a list of documents still to be printed, as in Figure 7.2. You can also set the date and time for a document to be printed. PrintMonitor will alert you with a message if there are problems

with the printer, such as a shortage of paper. It will also notify you when a manual-feed job is about to start. PrintMonitor can be turned on and off in the Chooser when the LaserWriter driver is selected.

Figure 7.2

PrintMonitor queues print jobs and reports on their status.

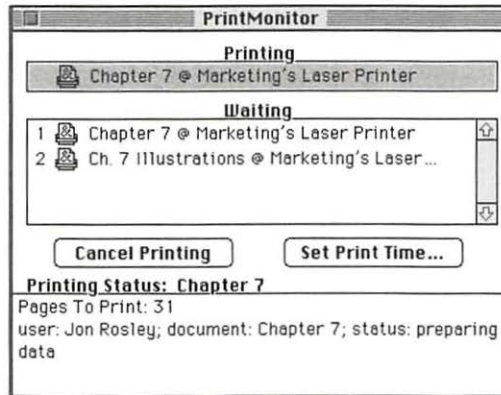

The AppleShare extension shown in Figure 7.1 implements AFP client services in your Mac, enabling you to connect to various AFP-compliant network volumes. These can be AppleShare servers running on Macs, shared volumes created with System 7's File Sharing, PC network operating systems such as Novell NetWare, UNIX servers, or VAX servers. Regardless of the computer storing the data, shared volumes appear mounted on the desktop, as shown in Figure 7.3.

Mounted AFP volumes act just like hard disks. You double-click to open volumes, folders, and files, and drag files and folders to copy between local and network volumes. You can disconnect from a network volume by dragging its icon to the Trash.

AFP volumes are shared with other users on the network. If you create a new folder on a shared volume, it appears in everyone's view of the volume. You can also limit access to a folder you create on an AFP volume by setting access privileges, which are restricted by user names and passwords. You can assign different levels of privileges as well: You can hide folders from a user's view, let a user see folders and files but not make changes, or enable a user to copy files to a folder, but prevent him or her from opening the folder to see its contents. Access privileges will be discussed in more detail in the section on AppleShare.

System 7's File Sharing adds an additional AFP function to your Mac, the ability to create small file servers on your hard disk that are available to others on the network. To network users, the shared folder on your hard disk

appears as a volume on their desktop, as pictured in Figure 7.3. Network users do not have access to any part of your hard disk other than to the folders you designate as shared. You can also designate one or more entire hard disks as a shared volume.

Figure 7.3

You don't have to add any software to your Mac to mount AFP servers running on different computers. The Mac shown here is logged onto file servers running on a Mac, a PC, a VAX, and a UNIX workstation

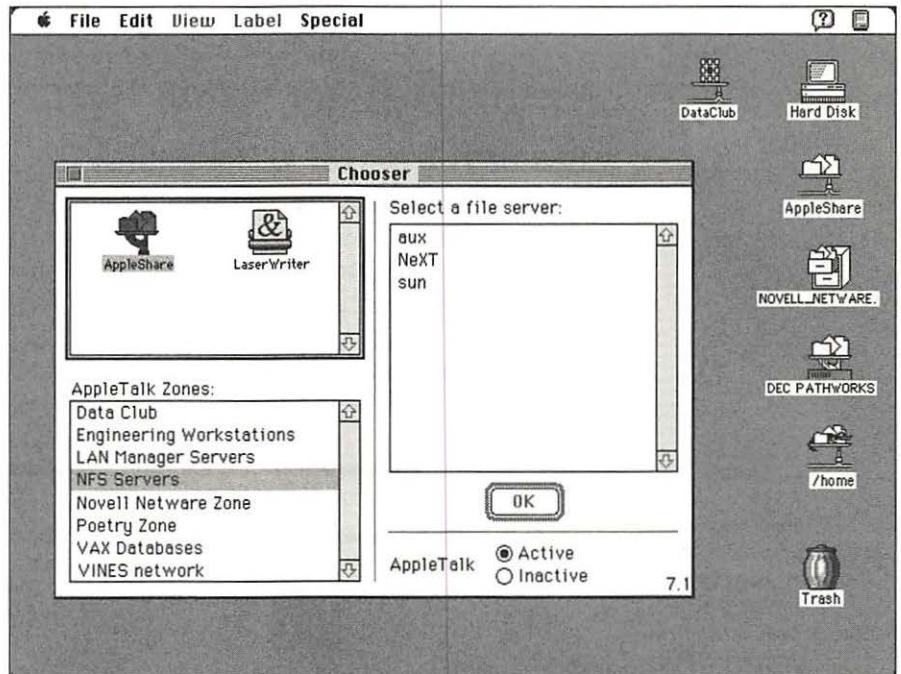

File Sharing is an easy way to pass files around. For instance, you can designate a folder on your hard disk as *shared*, dump your weekly reports into it, and have your coworkers pick them up and return comments to your shared folder at their leisure. However, File Sharing is not a replacement for a dedicated file server like AppleShare, but is, rather, a supplement. MacUser Labs testing has found File Sharing to have half the performance of an AppleShare file server for most tasks. File Sharing also has a limit of ten users logged onto a shared volume at one time.

It should be noted that Macs can also access non-AFP file servers running on various platforms. However, you'll need to add software to your Mac specifically for this purpose, and the method of access can vary with each vendor's product. Non-AFP access will be discussed in Chapters 8, 9, and 10.

■ Using Apple's Network Services

File Sharing and AppleShare are the first two file service methods likely to be used on a new AppleTalk network: the first because it's free, and the second because it's a natural and inexpensive extension of the first. Also, File Sharing and AppleShare work very well, and additional Mac-based services can be added easily. For many organizations, there is never a need to move beyond AppleShare. Other groups will find Apple's offerings a good transition to bigger, more complex systems. But before we get into the details of features, let's look at how servers deliver their services.

A Tale of Two Server Architectures

All network services are designed as either *distributed* or *centralized* applications. Distributed services deliver information directly between pairs of network devices in a point-to-point manner; there is no central distribution point for the services. Centralized network service software is located on a *server*, sometimes called a *host*, a single computer that delivers network services to everyone on the network. (See Figure 7.4.) The server can be a Mac, PC, or mainframe, depending on the server software.

Figure 7.4

Distributed network services are shared on a point-to-point basis. Centralized network services pass through a single computer.

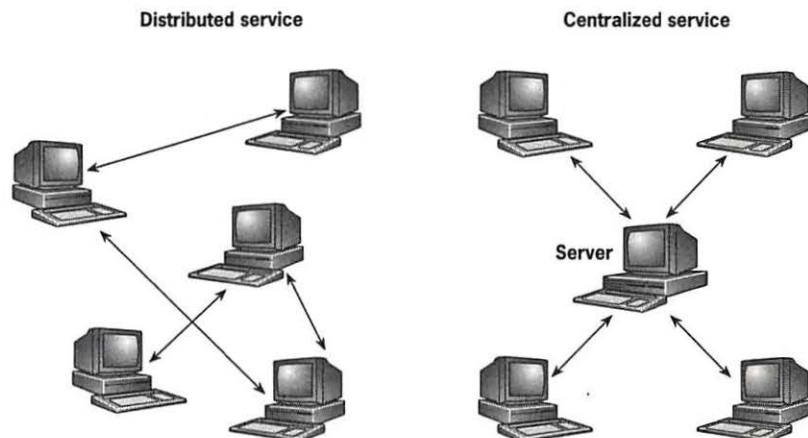

The terms *distributed* and *centralized* apply to all sorts of network services. System 7's File Sharing is a distributed file service, as is TOPS, a third-party file server from Sitka. AppleShare and Novell NetWare are centralized. System 7's PrintMonitor is a distributed spooling service, one Mac to one printer; the AppleShare Printer Server is centralized. Electronic mail and group calendars are usually centralized.

Centralized services are often described in terms of a *client-server* model. The client is the user's Mac, the computer that accesses the server. A server can often run more than one service at the same time, and a workstation Mac can be a client of more than one service.

Distributed services are often cheaper—free in the case of System 7's File Sharing—and centralized services are usually faster and offer more features. Distributed services are designed for small numbers of users. Centralized services are easier to back up, since all data is kept on one machine. Servers can also be locked in a room to prevent accidental shut off or tampering.

Both distributed and centralized services often are designed with a *store-and-forward* architecture. With a centralized service, the host Mac stores a piece of information, such as an e-mail message or a file, until the host can contact the recipient, or a user asks for it. This means that the recipient computer won't miss anything if it isn't turned on. Store-and-forward design is a common element of file serving, electronic mail, and group calendars.

When store-and-forward architecture is used in distributed services, the sender's computer looks for the recipient on the network. If it doesn't find the recipient because the recipient node is turned off or disconnected from the network, the sender's computer holds the message until the recipient node comes back on line. DataClub, a distributed file server from Novell, uses a store-and-forward architecture. PrintMonitor, on the other hand, is not a store-and-forward service—if the printer you've selected is not found, your Mac can't wait for the printer to come back on line and will ask you to cancel or reschedule the job.

File-Sharing Setup

As I've mentioned, accessing a shared volume on the network is not a big deal: It looks like any other AFP volume you see listed in the Chooser. Creating a shared volume, on the other hand, is a bit more complicated. First you'll have to open the Sharing Setup control panel to turn on File Sharing (see Figure 7.5). File Sharing will stay turned on until you turn it off, and starts up automatically when you restart your Mac.

The Network Identity section of the Sharing Setup control panel is used to give your Mac a password and a Macintosh name. This Mac name appears in other people's Choosers when they try to log onto your Mac, and is used by a variety of network software to identify the Mac. (The Macintosh name is called the Chooser name in pre-System 7 versions of the Finder.)

Typing your name in the Owner Name field automatically enters your name into the log-on fields of many network service log-on windows. In addition, a user with your name is automatically created in the Users and Groups control panel. This is the same control panel used by AppleTalk Remote

Access as shown in Chapter 4, Figure 4.2. It is here that you grant users permission to access parts of your hard disk (the shared volume you create).

Figure 7.5

The Sharing Setup control panel identifies you and your Mac to the network and lets you turn File Sharing and Program Linking on and off.

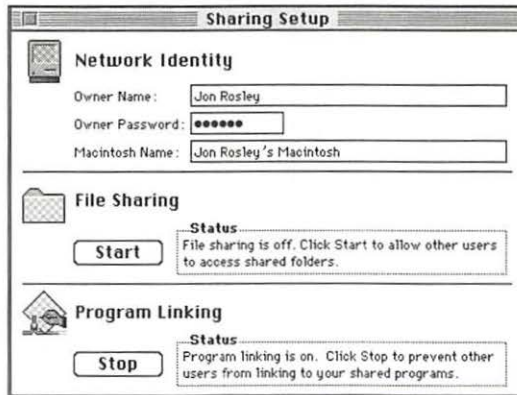

The Sharing Setup control panel is also used to turn on Program Linking, which enables network use of System 7's interapplication communications features, such as Publish and Subscribe. Turning on Program Linking allows applications that support Publish and Subscribe residing on different Macs to be linked over a network. Program Linking does not require File Sharing to be turned on, as it will work over AppleShare or any other file server or even without a file server.

After turning on File Sharing, you create a shared volume by selecting a folder on a hard disk, removable cartridge, or CD-ROM, and then choosing the Sharing command from the File menu. You can also share an entire disk. Removable cartridges become nonremovable (that is, the Mac won't let you eject them) if they contain a shared item. Floppy disks cannot be shared. In the window that comes up when you choose the Sharing command, you can set access privileges for the folder. When you close the Sharing window, your folder icon turns into a shared icon, as shown in Figure 7.6.

People who are copying files to and from the shared folders on your hard disk will slow down your Mac slightly, so you'll notice some jumpiness while you're typing. The more people accessing your shared folder, the greater the Mac slowdown. You can check to see who is accessing your Mac in the File Sharing Monitor control panel, shown in Figure 7.7. If the spirit of sharing gets to be too much for your Mac to handle, the File Sharing Monitor control panel also lets you disconnect a user who is accessing your Mac, giving you your Mac's processing power for your own work.

Figure 7.6

Folders that you designate as shared get a new icon in the Finder.

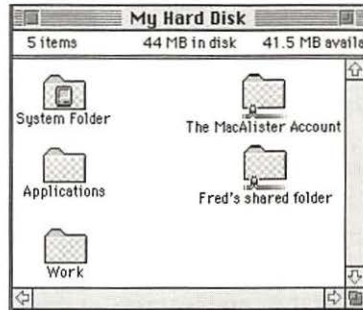
**Figure 7.7**

The File Sharing Monitor control panel lets you see who is accessing your shared folders.

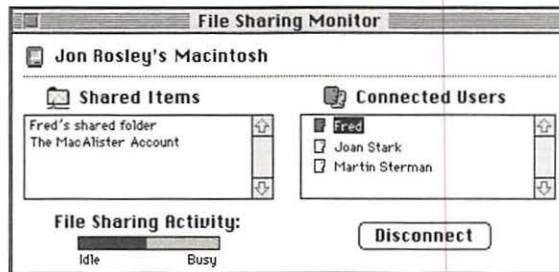

You can use a System 7 alias to simplify the process of logging onto a network volume, just as you can with AppleTalk Remote Access, as discussed in Chapter 4. When making an alias of someone's shared volume or a file server, a double click on the alias will bypass the Chooser and log on for you, prompting you for passwords. This method is particularly useful when combined with File Sharing: It enables you to virtually carry your hard disk on a floppy disk.

To do this, first designate your entire hard disk as a shared volume, so it can be seen over the network. Next, while still at your Mac, make an alias of your hard disk. Since an alias takes less than 2k of disk space, you can copy the alias to a floppy disk. Next, take the floppy disk and carry it around with you. Insert the floppy disk in any Mac on your network running System 7 and double-click on your hard disk alias. The alias will find your Mac and its hard disk on the network, and mount it on the Mac you happen to be using. This technique is a great tool for network managers and people who move around a lot.

The AppleShare File Server

The AppleShare File Server is Apple's AFP-compatible centralized file server product. In fact, it was the original AFP file server. It is not a network operating system like Novell NetWare and Banyan VINES, but a network application that runs on top of the Mac operating system on a host Mac. It doesn't have all of the features of a PC-based network operating system, but it is the easiest centralized file server to set up and manage, and has good performance.

AppleShare versions 3.0 and later require System 7 on the server, but client Macs can use either System 7 or earlier. AppleShare can run concurrently with other server software, such as electronic mail, but it is not recommended for running user applications. A crash resulting from a word processor, for example, will bring down the server, affecting multiple network users.

The AppleShare server software supports multiple disks on a server and can make server volumes out of erasable optical and CD-ROM discs. AppleShare 3.0 or later allows you to eject removable cartridges without shutting down the server, something not possible with System 7's File Sharing. AppleShare 3.0 also comes with a centralized print spooler, the AppleShare Print Server.

AppleShare 3.0 allows up to 120 Macs, PCs, and Apple IIs to log on simultaneously to one server. (PCs require additional software, as described in Chapter 2.) Network administrators can set the maximum number of users to a lower value to optimize performance.

Security Features

After selecting the server and volume you wish to mount on your hard disk, you'll be asked for a password, set by the network administrator. You can change your password at any time. In fact, the administrator can require new users to change their passwords the first time they log on.

Any AppleShare user logged on the server can create a folder on an AFP volume and assign it access privileges to limit access by others. You create a new folder the same way that you do on your own hard disk—by choosing New Folder from the File menu when an AFP volume is mounted and its window is open and selected. Access privileges can be assigned to folders (but not files) by selecting the folder and choosing the Sharing command from the File menu. With version 3.0 or later, privileges are inherited, so that any folder created inside a shared folder defaults to the privileges of the parent folder.

There are three types of access privileges—See Folders, See Files, and Make Changes—which can be assigned individually or in any combination (see Figure 7.8).

Figure 7.8

To limit access to a shared folder or volume, users can set combinations of three types of access privileges: See Folders, See Files, and Make Changes.

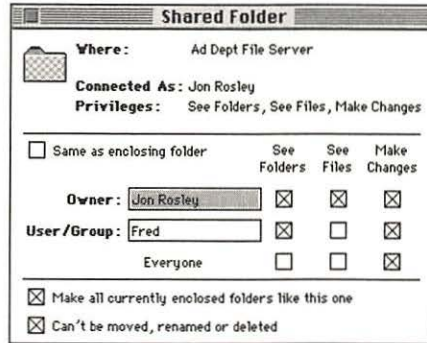

The See Folders and See Files settings give other users read-only privileges, like a CD-ROM disc. Users can read and copy any files or folders, but can't edit documents or add or delete files and folders. Make Changes is a write privilege: With See Files and See Folders turned off, Make Changes is write-only, allowing users to drop files into a folder but not to open the folder to see its contents. A write-only AFP folder is called a *drop box*. You can tell which privileges have been assigned to a folder by the shape of the folder icon when its window is closed, and by the symbols in the upper-left corner of its window when the folder is open (see Figure 7.9).

A set of access privileges assigned to a folder can be granted to the folder's owner, to individual users, to groups of users listed under a common name, and to anyone who logs on. These choices are represented as Owner, User/Group, and Everyone in Figure 7.8. The owner is the person who created the folder on the shared volume. You may even want to restrict your own access to prevent accidental deletion of files. If guest access has been enabled, people who are not registered users can log on as guests. Users can also log on to volumes as guests, which doesn't require a password. Guests can access any volume or folder that has privileges enabled for Everyone. Since guests can't assign access privileges, folders created by guests inherit the privileges of the parent folder.

Setting Up AppleShare

One of the great benefits of AppleShare is that anyone can set it up—you don't have to hire a consultant. Its easy setup procedure is an economic benefit, particularly for smaller businesses that don't have on-staff computer experts. Someone who has never seen the program before could set up a server in 30 to 45 minutes. Those familiar with AppleShare can set up a server in less than 15 minutes.

Figure 7.9

The icons of closed folders in AFP volumes reflect the privileges. An indicator may appear in the upper left of an open folder. AFP will also hide files or folders from view if See Folders or See Files is not checked. If neither is checked, you can't open the folder.

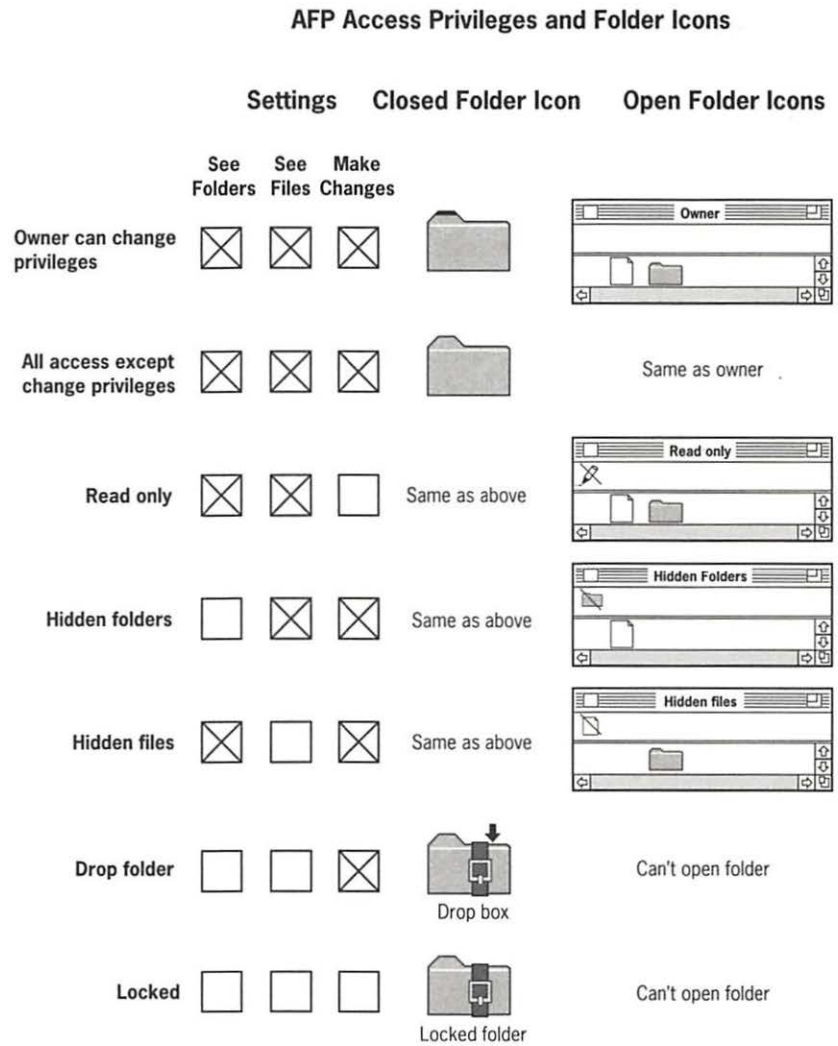

An AppleShare server is set up using the AppleShare Admin utility. Admin will ask you to create an Admin password, which will be used whenever you start the Admin program. In the same dialog box, you assign the server the name that will appear to users in the Chooser.

Choosing Create User from the Users menu brings up the User window, where you enter a user's name and password. You can leave the password blank and allow users to create their own, and you can require users to change their password after the first time they log on. The users' names

should be the same as those entered in the Sharing Setup control panel on each Mac, so that the correct name will be inserted automatically into the Name field when they log on. The user is represented by an icon (see Figure 7.10). Double-clicking on a user icon opens the User window again, should you need to make any changes.

Figure 7.10

Creating users and groups with the AppleShare Admin program

User list

User window

Group list

Group window

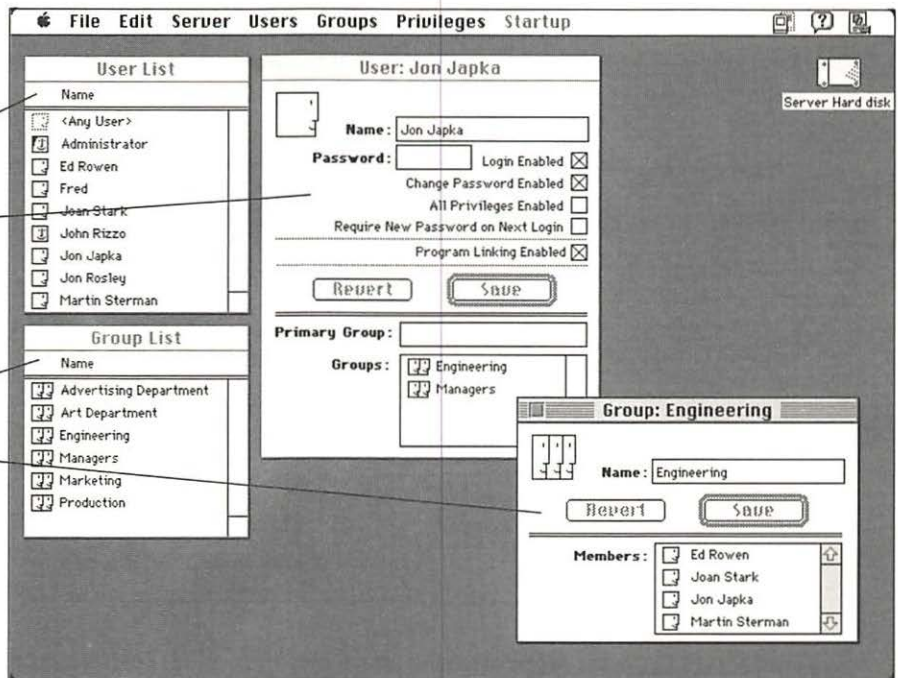

The first user information window to appear is about you, the administrator. As the administrator, you enjoy the privilege of being able to see the entire contents of all server disks, even portions that are not shared, such as the server's System Folder. If several people are charged with taking care of the network, you can give this privilege to other users by checking the All Privileges Enabled box in the User window.

A *group* is a collection of users who may need the same level of access privileges. For instance, setting up a group called Art Department lets you assign the same privileges to all members of the group at once. A user can belong to several groups. Creating groups is similar to creating users: Choose Group List from the Groups menu, and a Group window will appear. To assign users to the group, choose User List from the Users menu, and drag the

user icons into the Members field of the Group window. Alternatively, you can drag the group icons from the Group List into a User window (see Figure 7.10).

You'll next want to set up the shared network volumes. Choose the Access Information command from the Privileges menu to bring up the dialog box shown in Figure 7.11. Here you can select one or more hard disk drives or removable storage devices connected to the server Mac, and restrict access to a user or a group. You can also select particular folders on a hard disk to designate as shared volumes, leaving the remaining data on the hard disk unavailable to network users. Next, set the access privileges. You can prevent guests from logging on by not clicking any privileges in the Everyone box.

Figure 7.11

The Access Information window is where you turn folders and disks into AppleShare network volumes. Since CD-ROMs are read-only, Make Changes is disabled.

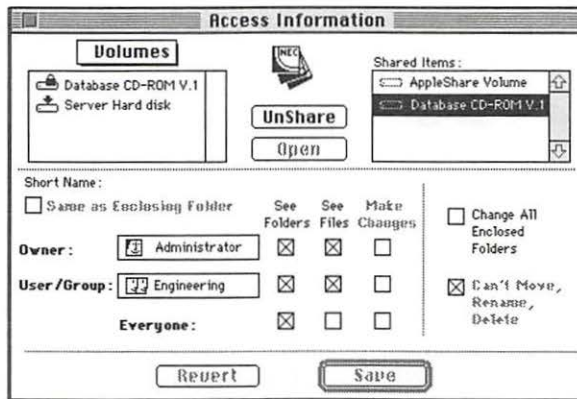

After you quit the Admin program, starting up the file server is a simple matter of double-clicking on the AppleShare File Server icon. Two status windows will come up displaying the active file server volumes and the names of any connected users. Also displayed is a thermometer that indicates the relative usage of the server.

There are several ways to adjust AppleShare for performance. If you are using the Mac for tasks other than AppleShare, you can use the slider bar in the Connected Users window to shift processing priority from the server application to your other tasks.

After a server is set up, the administrator can access the server through the Admin program from any Mac on the network. In addition to altering User and Group lists, administrators can send messages to users. The basic message informs users how long it will be until the server shuts down. AppleShare sends this message automatically when an administrator sets the time until shutdown (see Figure 7.12). An administrator can also set a greeting

message to be sent automatically to users when they log on. However, the log on message requires a user to click okay, and therefore hangs the Mac's boot process if the user has set the volume to auto-mount at startup.

Figure 7.12

AppleShare administrators can send a shutdown warning to users.

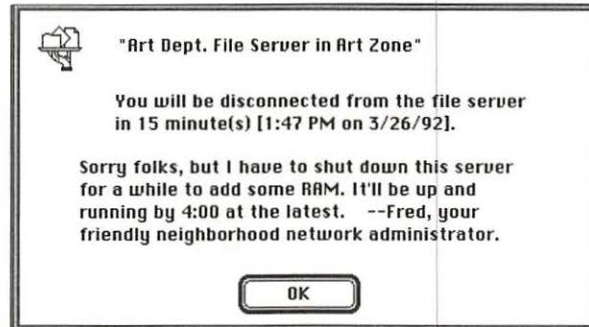

AppleShare Print Server

AppleShare 3.0 added the Print Server, a centralized network print spooling application, which formerly was sold separately. Instead of sending a printer requests for printing, Macs send their print jobs to the spooler, which then sends them to the printer one at a time. The AppleShare Print Server supports print spooling for up to five AppleTalk printers located anywhere on the network.

The Print Server can display a list of pending print jobs for each printer, showing the names of the users and files and the number of pages. It also keeps a log of these jobs (see Figure 7.13). Network administrators often keep Macs running AppleShare Print Server in public view, since the print job list helps users decide whether to cancel the print job or choose another printer if too many long print jobs are ahead of theirs.

The print spooler appears in the Chooser as another printer choice. Administrators can enable users to bypass the Print Server, which causes both the printer and the print spooler to appear in the Chooser. If a user selects the printer directly, it will compete with the Print Server on a first-come, first-served basis.

As with the AppleShare 3.0 file server, the Print Server runs on System 7 and supports both System 6 and 7 users. System 6 users should have the LaserWriter driver version 7.0 or above in their System Folder if there are System 7 users on the network. The two versions of the LaserWriter driver are incompatible, and will cause the printer to reinitialize every time a user with a different version tries to print. People using the System's PrintMonitor can use the AppleShare Print Server without any ill effects.

Figure 7.13

AppleShare's Print Server can spool up to five network printers and display current queued print jobs and a log of completed jobs.

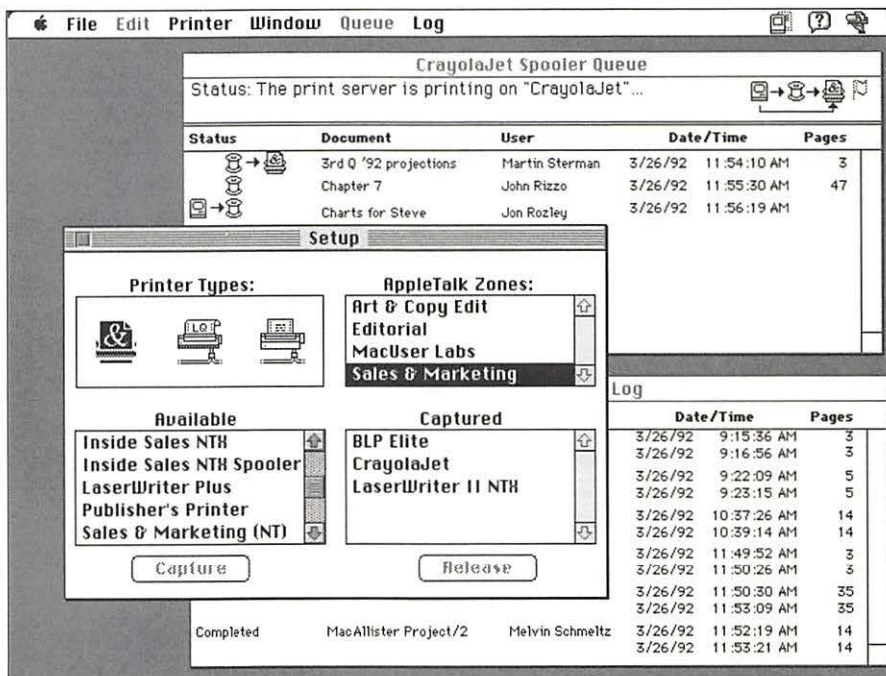

■ Using Third-Party Mac Services

Although Apple literally set the standards for AppleTalk file and print services, other companies offer competing network applications as well as some services not offered by Apple. Third-party services can be distributed or centralized and can run on Mac workstations and servers alongside Apple products. What follows are the more important services and products.

An Alternative File Service

Novell's DataClub is an AFP-compatible distributed file server that resembles a centralized file server. Like a distributed file service, there is no central file server Mac: All the shared data resides on individual Macs. The difference is in how you access shared data. With a distributed file service such as System 7's File Sharing, you'd have to mount and search each shared volume in order to browse files residing on other users' hard disks. With DataClub, you look for data on a single *virtual* file server, a logical volume that keeps shared data stored on the Macs of every user. Like any AFP volume, you use the Chooser to log onto a DataClub virtual server, which then mounts on your desktop.

When you copy a file to the virtual server, other users see it appear on the virtual server, but the file is actually stored on your hard disk. You can also set DataClub to store new folders you create on another Mac that might have more disk space than yours (see Figure 7.14). Users can also prevent you from creating folders on their Macs. Users browsing a mounted virtual server can't tell where the folder is actually residing unless they look at the folder's Get Info dialog box.

Figure 7.14

DataClub lets a user create new folders on other Macs on the network. Users view files residing on multiple Macs as residing on a single virtual server.



Each Mac using DataClub keeps a directory of what's in the virtual server volume, which helps make DataClub faster than System 7's File Sharing and as fast or faster than AppleShare. The directory also prevents confusion if some of the Macs containing shared data go off line. If a Mac is turned off, the shared folders residing on it are still visible to other users of the virtual file server volume, but are grayed out, indicating that they can't be accessed. The folders become available as soon as the Mac rejoins the network.

DataClub has some advantages over a traditional distributed system such as System 7's File Sharing. In addition to being faster, DataClub is easier to back up, since all the data appears on a single AFP volume. It is also easier for a network manager to keep track of users and groups with DataClub than with System 7's File Sharing, which creates users and groups on each Mac. DataClub users and groups only need to be set up once—the information is automatically distributed to the other Macs on the network.

DataClub costs less to operate than AppleShare does, because it doesn't require a server Mac or large hard disk drives. However, DataClub makes it more difficult for a network manager to keep track of data, since shared folders are scattered among Macs across the network. The administration burden is somewhat relieved by an included utility that enables a network manager to find out the locations of folders.

The utility also provides information on who accesses which folders and how often; this will help managers to place files and folders with the Mac users who use them the most. For instance, if Gina is the main user of a database located on Fred's hard disk, the network manager could move it to Gina's hard disk. Users would not see any difference on the virtual server, but Gina would have faster access to the database; Fred would no longer experience the slowdown of Gina's frequent accesses; and network traffic would be lessened. Managers can also relocate folders from Macs with little disk space to those with more disk space, or to those Macs which are not used heavily.

As mentioned above, distributed services hit their limit at about 10 users. Novell has a 50-user version of DataClub, DataClub Elite, that lets a network manager integrate one or more dedicated Macs into the virtual server. The file service is still distributed, but most of the data can be set to reside on the dedicated Mac. DataClub also includes a gateway that allows PCs on AppleTalk to log on, but the PCs can't store any data as part of the virtual server.

Print Services

With laser printer services pretty well wrapped up by the Mac's built-in functionality, developers have turned their talents to printers that are not designed for network use. Several products are available that take non-networkable serial printers, such as ink-jet and label printers, and make them available to AppleTalk users via the Chooser. Shiva's NetSerial is one such product, consisting of a box with a serial port and a LocalTalk port. The printer appears as an AppleTalk node that can be located anywhere on a LocalTalk network.

A more full-featured solution is a serial server, such as HayesConnect, server software that runs on a Mac. Serial printers and modems are connected to the server Mac, which then makes them available to AppleTalk users on LocalTalk, Ethernet, or any other data link mechanism. Although the Mac has only two built-in serial ports, more can be added with a multiport NuBus card. Additional serial ports enable users to take advantage of a feature called *device pooling*, which groups serial devices together. Client Macs view the pool as a single icon; if one serial device is being used, HayesConnect automatically substitutes another from the pool.

The market for third-party print spoolers has diminished since Apple built PrintMonitor into the system software a few years ago, but there are a few third-party print spoolers left that offer features not found in PrintMonitor. SuperLaserSpool from Fifth Generation predates PrintMonitor by several years and offers better speed than PrintMonitor plus the ability to load a batch of print jobs and distribute them to multiple printers across the network.

Desktop publishers like SuperLaserSpool for its ability to spool PageMaker documents, a task that PrintMonitor can't do.

Distributed spoolers such as PrintMonitor or SuperLaserSpool won't tell you if the printer is already busy before you start your print job. AppleShare Print Server will, but you have to walk over to the server to look at the print queue list. Blue Parrot from Casa Blanca Works is a handy utility that lets you see a print queue list from your Mac. For each printer on the network, Blue Parrot shows you who is currently printing and what file is being printed.

Electronic Mail

After file and print services, electronic mail (also known as e-mail) is the most useful network service you can install on a LAN. E-mail allows people to communicate with each other at their own time and pace. With e-mail, brainstorming between co-workers who don't have time to meet can occur over a period of days or weeks. Office memos can be sent over e-mail rather than on paper—click a button and copies of a message can be sent to everyone in the office.

E-mail packages usually consist of server and client software. The servers are based on store-and-forward architectures, so a message will be stored by the server software until the recipient chooses to read it. You can also install e-mail gateway software, which allows you to send text messages to users of other types of computers. Gateways to commercial on-line services' e-mail, such as MCI and America Online, enable you to send messages to users in other cities right from your friendly LAN-based e-mail window.

LAN-based e-mail systems offer more features and better interfaces than do on-line services. Except for the remote dial-in capabilities of most e-mail packages, LAN mail runs at the speed of your LAN, not your modem, as do on-line services. LAN-based e-mail enables you to send and receive text, pictures, data and application files, and even voice messages between Macs. You can send an e-mail message to multiple users as individuals or as a group you've created. You can also enclose multiple files.

Most of the available e-mail packages work in a similar manner. An e-mail message addressed to one or more people is sent to a mail server running on a Mac or PC, where it is held until a recipient asks for it. Messages are sent in a window called a *form*. Most e-mail packages contain several different forms for text, voice, and graphics. You can usually create your own forms to give messages a personal look.

E-mail services notify each recipient when a message has arrived. An e-mail received message window displays a list of messages that have been read as well as messages that are new. Deleting a message from the message list window deletes the message from the server, where it is stored. The sender of a message can select to receive return receipts, messages that tell

you that a user has read the message you sent. Most e-mail packages can create a log of messages you have sent, which you can open and reread. You can also download messages to your Mac's hard disk. Figure 7.15 shows some common e-mail features.

Figure 7.15

Top e-mail packages such as Microsoft Mail offer the ability to send text, graphics, and sound messages over a network.

- Button for addressing message to recipients
- Indicated files enclosed with message
- Return receipts
- User-created folders to store messages on server
- Copies of messages sent to other users

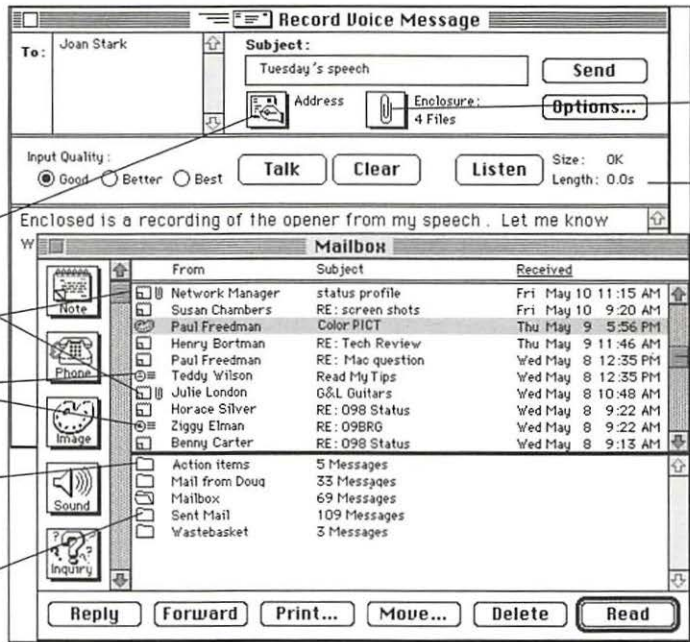

- Button for enclosing files
- Message sending window (voice and text)
- Received mail window

An Overview of Electronic Mail Packages

Shoppers for e-mail services have several good packages from which to choose. Microsoft Mail and CE Software's QuickMail have the biggest installed base of Macintosh e-mail nodes. Microsoft Mail has one of the most advanced network architectures and good performance; QuickMail is a full-featured package with slow performance, particularly on large networks. The top two packages have been joined by cc:Mail, which, until recently, was a slow, featureless program popular with PCs but with little to offer Mac users. This changed with the 2.0 version, which increased speed and added several innovative features. WordPerfect also has an e-mail program bundled with its WordPerfect Office calendar and group file manager package, but it falls short of the big three in interface and features. All four of these packages have versions for both Macs and PCs.

An important feature of Microsoft Mail is that mail servers located in different zones automatically share and update their directories of users with the other mail servers on the network. This prevents the server from collecting dead mail, sent to former employees no longer listed in the directory. But, with QuickMail, all users must manually update their list of users and groups when a network administrator deletes names from servers in other zones. If users don't update their own directories, the QuickMail server can accumulate messages addressed to people who no longer work at the company.

Microsoft's advanced server architecture also benefits users by enabling them to choose to see a list of all the users on the network, not just those in one particular zone, as with other e-mail packages. This makes it easier for a user to send messages across multiple zones. Microsoft has also built Mail links into Word and Excel. Choosing the Send Mail command in Word and Excel will open a Mail message with the Word or Excel document the user is working on automatically enclosed. All the user does is pick the recipients.

QuickMail's many features are popular with users. These include resizable windows, easily customizable mail forms, and a live conferencing mode. The Unsend command will let the sender delete a message that was sent before the recipient has received it. The Unread command returns a message icon to its unread state, which can be used for highlighting important messages.

The Macintosh version 2.0 of cc:Mail introduced features never before seen in electronic mail packages (see Figure 7.16). For instance, users can open or print enclosed files created by any application that supports XTND (discussed in Chapter 2) without having the application on their hard disk. Built-in file extension mapping enables Mac users to double-click on DOS files that are enclosed with e-mail messages. You can also read enclosed files without having to first download them to your Mac. With cc:Mail, users can also send formatted text which includes bold, italics, or mixed fonts. A find utility lets users perform full text searches of messages and user directories.

The only package that does not use a client-server architecture is cc:Mail. There is no server program, only a mail file called the Post Office, which is accessed by the client software. The server volume doesn't have to be mounted; the cc:Mail client remembers where on the network it is located. The Post Office file is platform independent, and can be stored on any network volume, which can be AppleShare, System 7's File Sharing, Novell NetWare or Banyan VINES. Gateways to PCs aren't necessary, because Mac and PC clients can access the same Post Office file.

There are also ways to use Novell's Message Handling Service (MHS) mail system from your Mac. MacAccess from Da Vinci Systems makes your Mac a fully participating MHS mail client through a desk accessory. You can also communicate with MHS users through QuickMail for MHS, a gateway software package from CE Software that lets you access the MHS

mail server from within QuickMail. There are also gateway software products available that connect on-line services to your LAN mail system, so you can send AppleLink messages right from QuickMail, for example. MCI offers CommGate/MS and CommGate/QM, its gateways to Microsoft Mail and QuickMail.

The nature of e-mail programs is bound to change with the acceptance of Apple's Open Collaboration Environment (OCE), which will add many e-mail functions to System 7. OCE is the subject of Chapter 14.

Figure 7.16

Lotus's cc:Mail 2.0 for Macintosh introduced advanced mail features, such as the ability to open various types of files without having to download them. Just double click, and even DOS files open within the mail window.

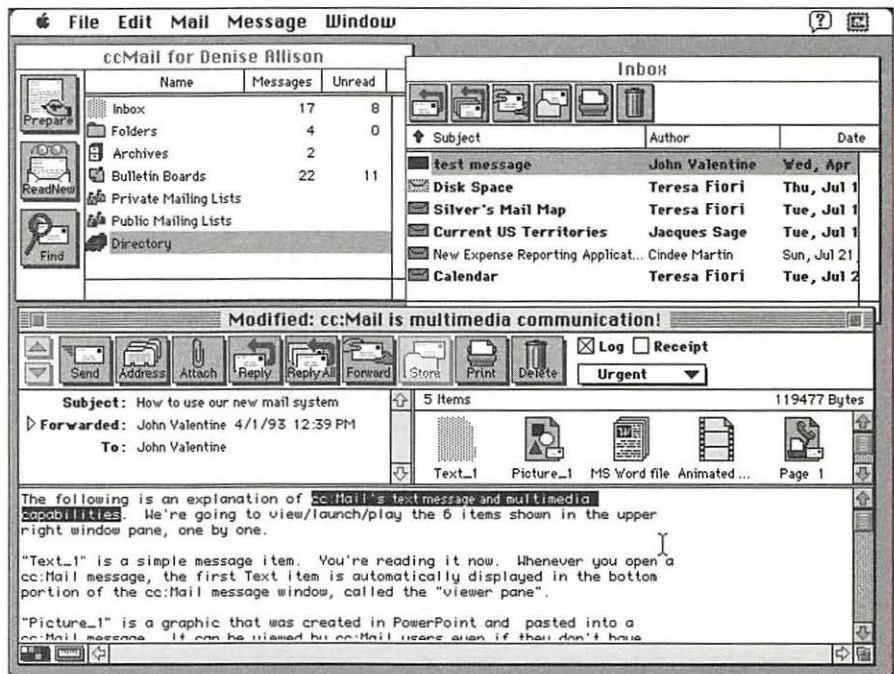

Databases

Shared databases of collected information can be useful on a network. While the file containing the data resides on a file server, the multiuser database application can reside on file servers or on each user's Mac. Although two users can't write to the same record at the same time, they can access different records in the same database file. Database applications such as Claris's FileMaker, Acius's 4th Dimension, and Blyth's Omnisc are examples of programs that can be used over a network.

A much faster database set up than a database on a file server is a *database server*, which is a server application that processes requests for database information and retrieves data from the hard disks themselves, rather than relying on file server software to pass information to clients. A database server knows where on the hard disk to look for information, whereas a database on a file server doesn't. In addition, only the data requests and found data are transferred over the network with a database server. A file server sends the entire database over the network to your Mac.

EveryWare Development's Butler is a database server that runs on a Mac. Using Apple's Data Access Language (DAL), Butler can communicate with Mac clients running 4th Dimension or any other DAL-compatible database application. Macs can also access database servers running on more powerful computers using a DAL-compatible database application or one of a variety of retrieval applications such as Brio's Data Prism. Chapter 11 covers connectivity between database clients and servers running on different computers.

New Services

As more and more networks become established, new uses for them are developed. These network services often repeat a task that is traditionally done on paper. Group editors are an example of a class of software called workgroup applications. Instead of passing around a text or graphics document for comments from a group of people, users can simultaneously access a document on their Macs and add comments.

Group schedulers or calendars are handy alternatives to personally confirming information with many people; you can simply set up a meeting or reserve a conference room. There is a blurry line between group calendars and schedulers, but the latter generally possess a higher degree of intelligence. For instance, Now Up-To-Date from Now Software is a calendar server that can display appointments for group activities as well as those of selected individuals (see Figure 7.17). Users can see when conference rooms are free and when co-workers have time available. On Technology's Meeting Maker is a group scheduler; it goes a step further and will automatically search for free time slots for the users with whom you are trying to set up a meeting.

Electronic bulletin boards for local area networks offer a private forum for a casual exchange of ideas. Pacer Forum is an example of a well-executed LAN-based bulletin board. Like the bulletin boards offered by on-line services, LAN-based bulletin boards allow people to post comments and seek answers to questions. LAN bulletin boards can be used for company-wide discussions among people who work in different departments and would not ordinarily have a chance to get together.

Figure 7.17

A group calendar server such as Now Up-to-Date helps an organization schedule meetings and conference rooms.

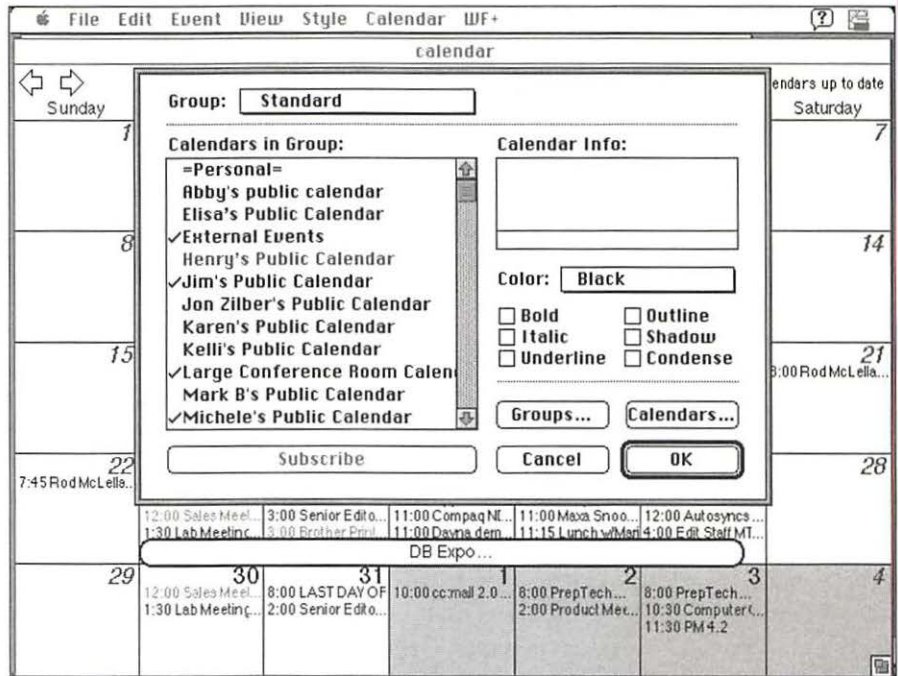

Distributed processing is a service that, instead of sharing information, enables computational-intensive applications to share the processing power of a network's computers, some of which are likely to be idle part of the time. Processing servers can be computers dedicated to the task of providing extra number-crunching power. Processing servers could also be the Macs of users who can spare some of their CPU time.

Distributed processing servers for the Mac were first provided for photorealistic rendering, a task that can sometimes take hours on a fast Mac. Strata's RenderPro is a distributed processing server package for StrataVISION 3d, a photorealistic rendering application. RenderPro can set up multiple Macs to handle portions of a single StrataVISION rendering job. When the portions are completed, they are passed back to the Mac running StrataVISION. All rendering is conducted in the background, so the render servers can still be used to run other programs. If the RenderPro program is canceled on one of the servers or if a server is shut down, the Mac running StrataVISION shifts the work to another Mac.

Pixar has similar software called NetRenderMan, which can send rendering jobs from a Mac running MacRenderMan to both Macs and UNIX workstations such as Silicon Graphics's Indigo, a very fast RISC-based machine

designed for high-end graphics processing. A UNIX application acts as a RenderMan server, receiving rendering requests from Macs and delegating rendering jobs to available machines on a TCP/IP network. Pixar's solution gives users the best of two worlds, the Mac interface with the speed of a RISC processor.

■ Using the Mac as a Server Platform

People won't use network services that are slow enough to be annoying. The server Mac and the add-in hardware inside of it can greatly affect the performance experienced by users; this becomes increasingly important as more users log on. But before you go out and buy the most expensive Mac you can find, you need to consider the location of the bottlenecks in the network. The data link mechanism, server RAM, and server hard disk are all factors. In addition, there are some rather slow types of data storage devices that nevertheless offer useful features when used as server disks.

Which Mac Server?

On a LocalTalk network, the speed of the network can't keep up with faster Macs, so using anything faster than a IIsi is a waste of a good Mac that could be better used on someone's desk. Switching to Ethernet or token ring will eliminate the LocalTalk bottleneck; this change will also mean that the Mac model used for the server will be an important consideration for good network service performance.

Avoid the temptation to turn your old Mac Pluses into servers. To make your network services usable and to allow for future growth, the minimum server platform should be a 68030-based Mac with a 32-bit data path between the CPU and memory. You can think of a 32-bit data path as a highway with 32 lanes—the narrower the highway, the more time it takes the data to get through. Several Mac models use a 16-bit data path, which takes about twice as long to move data as Macs with 32-bit data paths.

One discontinued machine that still makes a good server for 30 users or less is the now-discontinued SE/30. Its relatively low cost, built-in monitor, fast processor, small size, and expansion slot for an Ethernet card made it *MacUser's* recommended Mac server platform for several years. Although an SE/30 may seem equivalent to a Classic II—both are powered by a 16 MHz 68030—the SE/30 is a superior server, since the Classic II is a 16-bit Mac with no expansion slot.

A step up from the SE/30 is the Mac IIfx, which runs on a 25 MHz 68030 processor. The IIfx contains on-board video, so all three of its NuBus slots can be used for network interface cards, making it a good platform on which

to run the Apple Internet Router. If you can do with a single expansion slot, the less expensive Mac IIci is almost as fast.

The Mac IIfx, with its 40 MHz 68030, has been measured by MacUser Labs to have performance almost three times that of the IIci—but not as an AppleShare server. This is because the IIfx’s SCSI port, the interface to the hard drive, is actually about 25 percent *slower* than that of the IIci. As a result, MacUser Labs has shown the IIfx to be only marginally faster than the IIci for some server tasks, and actually slower than the IIci for disk-access-intensive tasks. You can improve IIfx server performance, particularly for an e-mail server, if you use an Ethernet card in the processor direct slot, bypassing NuBus. Asanté has such a card for the IIfx processor direct slot.

For networks with many dozens of users and heavy server traffic, you may want to consider the top end of the Mac line. Apple designed the Quadra 950 with a server in mind (see Figure 7.18). Its built-in features include a 33 MHz 68040 processor and fast Ethernet throughput built right on the logic board. There is also space for up to three hard drives or tape drives. The Quadra 950 also has five NuBus slots for add-in cards, as well as a large 303-watt power supply to support any drives and cards you decide to add. The Quadra can be locked in the “On” position with a key that can be removed so there can’t be an accidental turn off. Using 16Mb RAM SIMMs, you can add up to 256Mb of memory.

Figure 7.18

The Mac Quadra 950 makes a good network server, with its fast 68040 processor, large power supply, and room for expansion.

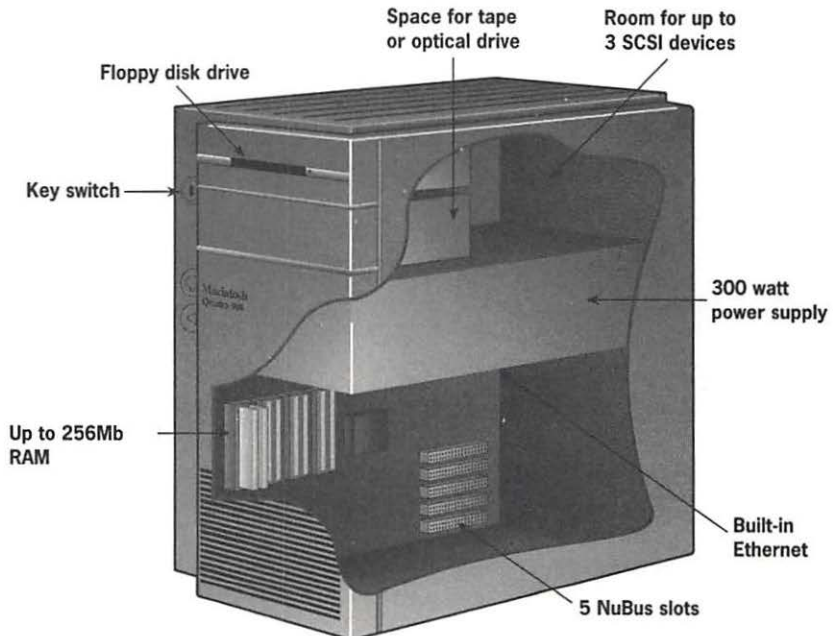

The amount of RAM can affect the performance of any Mac server, but after a certain point, it's wasted. A general rule is that a minimum of 4Mb should be installed for each service running on a Mac server, although servers running on System 6 can sometimes get away with less. Graphics rendering servers can use double and triple these amounts.

Servers running System 7 will be somewhat slower than those running System 6. If the server is a 68030-based Mac, it's a good idea to run each service on a separate Mac for up to 30 users. At over 50 users, you may need to split up the service onto two server machines. Mac servers based on the 68040 can handle more users and services, as long as the hard disk drive is fast enough.

Server Storage

The speed of the hard disk is an important factor in the performance of the server. Just how important depends on the type of server software running on the server Mac. Hard disks can be performance bottlenecks for services that access data in many small bites, as opposed to reading or writing fewer, bigger chunks of data. Electronic mail servers frequently access small pieces of data, as do databases. File servers used to transfer large files to and from a server hard disk access a disk less often, and don't tax a server disk as much. Frequent transfer of large files, however, can tie up other parts of the server hardware, software, and network.

During normal use, data files on a disk will become fragmented, scattered about the disk in pieces. Searching for these pieces slows performance. The solution to this problem is to periodically put the pieces back together, or defragment, the disk using one of many utilities available for the purpose, such as Symantec's Norton Utilities for the Macintosh or ALSoft's DiskExpress II. DiskExpress II can be set to monitor a disk's fragmentation, and can automatically perform defragmentation when the server is idle or at pre-set time periods. It's a good idea to defragment a server disk only after you've made a backup.

You'll also need to consider the amount of storage you'll need. It's easy to underestimate how much capacity you'll need on your file server disks. If you're running a print spooler, be sure to allow some space for spooled print jobs; printing graphics files will require quite a bit more disk space than printing text files. Electronic mail servers don't require as much disk space as file and print servers.

Fortunately, the higher the capacity of the hard drive, the faster it tends to be. Several hard drives that store a gigabyte (1024 megabytes) or more are available in the 3.5-inch form factor, which means they can fit inside a Mac IIci. These drives are some of the fastest on the market, some with access times under 10 milliseconds, and can be purchased for under \$2,500.

However, if you're going to collect this much data in one place, you'll need something that can back up large amounts of data. DAT (digital audio tape) is a good server backup medium, with some brands of drives holding as much as 8 gigabytes.

For a more permanent archive that can also be made available to users over the networks, you might consider erasable optical removable cartridges. 5.25-inch cartridges can hold up to a gigabyte of data, and 3.5-inch cartridges can hold up to 128Mb. Although much slower than hard disks, erasable optical media have a 100 percent data reliability life of about 30 years, far greater than magnetic media. It is not a good idea to put operating system or network applications on optical disks, which should be used as a supplement to hard disks, not as a replacement. Optical jukeboxes, drive units that can hold multiple disks, sometimes offer a feature called *spanning* that allows several of the disks to appear as a single shared volume, some as large as 4 gigabytes.

■ Outgrowing a Mac Server

AppleShare was a breakthrough when it first appeared in 1987, but a gap of three years (a very long time for software) between versions 2.0 and 3.0 boosted the view that Apple realizes that AppleShare cannot compete with network operating systems as a high-end server. Roger Heinen, vice president and general manager of Apple's Software Architecture Division, has stated publicly that there may not be an AppleShare 4.0 for the current 680x0-based Mac servers. The reason is that AppleShare requires the Macintosh operating system. For all its connectivity features, the System and Finder were designed as a workstation operating system. As a server, the Mac has limitations. For one, a lot of processing power that could be going to server applications goes to creating a user front end.

Another limitation of the Mac operating system is that it does not offer true multitasking. Although multiple applications can be run at the same time in the background, the different application processes are not protected from one another. This means that if a mail server, which is running as the foreground application, crashes, a background file server crashes as well. In addition, background tasks can slow down tasks running in the foreground, and vice versa. Network operating systems such as NetWare and VINES, and host operating systems such as UNIX and VMS, can run multiple applications as completely independent processes—a network server doesn't affect the stability of another application running on the same machine. This capability is called *preemptive multitasking*; it also helps to keep the slowdown due to applications running in the background to an imperceptible level.

There are two choices when a workgroup outgrows a Mac server: The network servers can be distributed by adding more Mac servers, or the Mac network services can be moved to another server platform designed for the task. Choosing the latter option can offer new capabilities and speed, but there are trade-offs that result in increased costs and complexity.

Integrated PC-Based Network Operating Systems

PC-based network operating systems cannot only add Macs to PC networks, as discussed in Chapter 2, but are also viable for high-end Mac-only networks. Besides providing fast AFP-compatible file service, they provide print, e-mail, and database services, as well as increased data reliability features, all on a single PC server. It's not that 80386- or 80486-based PCs are better hardware than Macs, but rather that the network operating systems are written specifically to handle these tasks. In addition, data is stored in highly optimized proprietary formats on the server hard disk. Disk access is further speeded up by caching techniques that store frequently used disk information in RAM.

Network operating systems usually run proprietary network protocols on PC networks, but have optional AppleTalk add-ons and built-in gateway and router functions. Printers are traditionally connected directly to the server PC via serial or parallel ports, but AppleTalk printers can still be used in the standard Macintosh fashion, as nodes on the network. There are also connections to mainframes and wide-area networks, but these are no better than the connection methods available to the Mac.

Fortunately, the two most highly rated network operating systems, Novell NetWare—the most popular—and Banyan VINES each offer add-ons for Mac networks. Let's take a look at what these systems can do for your Macs.

NetWare for Macs

It is ironic that Novell NetWare has become synonymous with the Intel 80x86 line of processors, since NetWare originally ran on the Motorola 68000 as the operating system for the long-discontinued Novell S-Net. These days, NetWare's file, print, and SQL database can be accessed by up to 100 Macs if two Novell products are running on the PC server: NetWare and NetWare for Macintosh. Novell offers several versions of NetWare with different features and prices.

From the Mac user's point of view, NetWare for Macintosh provides AFP file service that is faster than AppleShare. Tests at MacUser Labs have shown NetWare 3.11 with NetWare for Macintosh 3.0 to be significantly faster than AppleShare on an Ethernet network. However, testing has also found that users won't get any performance enhancement on LocalTalk, which limits both NetWare and AppleShare performance.

In addition to enabling the user to select NetWare servers through the Chooser, NetWare for Macintosh provides Mac users with a desk accessory to access NetWare services. The desk accessory can be used to set and view access privileges, called security rights in NetWare. A rudimentary e-mail function and a printer queue display are also accessed with the desk accessory.

An option that doesn't run on the main NetWare server is the Access Server, a DOS *application server* that downloads applications from server to client when requested. On a Mac, Access Server works like Argosy's RunPC, described in Chapter 2. A window appears on the Mac containing a DOS application. Access Server requires its own dedicated PC in addition to the PC running NetWare.

From the network manager's point of view, the NetWare operating system provides features that enhance data reliability. To verify that data recorded on a disk is reliable, NetWare performs a read-after-write verification when data is written to the hard disk. Disk mirroring and disk duplexing are two strategies that can be used to protect data from faulty storage devices. Disk mirroring uses a single controller to write identical data onto two hard disks at the same time. The duplicate disk will take over automatically if the original disk fails. Disk duplexing uses two controllers to simultaneously write to a pair of disks and is the faster and more secure method. (Disk duplexing is also available for Macs with Golden Triangle's DiskTwin, but is slower because it is not built into the Mac's operating system.)

The drawbacks to NetWare involve costs and time. For 20 users, the combination of NetWare 3.11 and the required NetWare for Macintosh costs a whopping five and a half times what you would pay for AppleShare. A less expensive alternative is to use Dayna's NetMounter in place of NetWare for Macintosh. Unlike NetWare for Macintosh, NetMounter is installed only on the client Macs. NetMounter receives IPX packets from the NetWare server, and translates them into AFP information to display a NetWare server volume as a mounted AFP volume. The only feature that Dayna doesn't provide is Novell's desk accessory containing the print service and e-mail.

With either method for implementing NetWare, you give up AppleShare's simplicity. Unless you've had experience installing NetWare, you'll most likely have to hire a certified NetWare consultant to install it. You'll also need two PCs for NetWare, one for the server and one to act as the management console. Network administrators can use a Mac to add and delete users and groups and to assign passwords and file attributes. Administrators can access the full suite of PC-based network maintenance software from their Macs using the Access Server option.

The Banyan VINES Option

Banyan's VINES network operating system, based on UNIX, first shipped in 1984, a year after NetWare's debut. VINES offers many of the network services and reliability features of NetWare. The first version to support Macs was version 5.0, which requires the VINES Option for Macintosh. Unlike NetWare, there is no limit to the number of Macs that can be connected to a VINES server. VINES Mail for Macintosh is an add-on that is a bit more robust than Novell's offering, but its interface has the look and feel of PC software and is not up to the level of the four e-mail packages mentioned above.

VINES distinguishes itself in its ability to locate network resources and services in very large internets and wide-area networks. VINES uses a feature called the StreetTalk Global Directory Service to distribute lists of users, file servers, printers, e-mail addresses, and gateways. (This type of directory service is similar in concept to Apple's Open Collaboration Environment, the subject of Chapter 14.) StreetTalk enables any user to access any other user, resource, or application on a VINES network. With NetWare, much of this type of addressing information must be specified manually by a network administrator. StreetTalk is not as simple or as elegant as simply using the Chooser, but it is more efficient in very large networks. Using Banyan's StreetTalk Directory Assistance menu item, a Mac user could update listings on an internet of several thousand nodes in a matter of seconds, a simpler procedure than scrolling through hundreds of zone lists in the Chooser.

On the negative side, Banyan VINES has many of the same drawbacks of NetWare. A setup for Macs is more expensive than NetWare for a few dozen Macs, but less expensive than NetWare for large numbers of Macs. Either way, the cost is significantly higher than AppleShare. VINES is simpler to set up and easier to manage than NetWare, mostly because of its global directory structure. Still, VINES is much more complicated to set up and administer than AppleShare, and offers no network administration functions from a Mac.

RISC and VAX Servers

Intel-based PCs have their limitations as well. You may need a more powerful computer, such as a RISC-based UNIX workstation or a Digital Equipment Corporation VAX running the VMS operating system. Generally speaking, RISC workstations can be thought of as super-fast desktop computers, and VAXes are closer to a miniframe. (This is why a VAX is often called a *minicomputer*. A PC is therefore called a *microcomputer* from this viewpoint.) Both RISC workstations and minicomputers require a deeper technical knowledge to manage than either Macs or PCs. Most sites have at least

one full-time specialist on staff. As network servers, both types of machines offer the advantages of high data security and the ability to handle large numbers of users and applications. AFP file service as well as gateways to popular Mac e-mail systems are available for both RISC workstations and VAXes.

A RISC-based machine might be a good choice for a server if you already use workstations at your site. RISC workstations are popular for CAD, engineering, and graphic design, among other tasks. Like dedicated network operating systems, UNIX is well-structured for distributing network services. UNIX workstations typically run on the TCP/IP network protocol and use file servers that are compatible with NFS (Network Filing Service), which is roughly equivalent to AFP in the UNIX world. In addition to accessing NFS servers, you can also run AFP servers on UNIX workstations. These and other Mac-to-UNIX connectivity options will be discussed in detail in the next chapter.

A VAX is particularly well suited for very large databases. For a VAX running VMS, AFP file services and other network services are available through packages such as Alisa's AlisaShare, Pacer's PacerShare, and Digital Equipment Corporation's PathWorks. Performance can vary greatly depending on the VAX model and its configurations. MacUser Labs tests found PathWorks running on a MicroVAX, the smallest of the line, to be a good deal slower than AppleShare running on a Mac. However, most sites don't install a VAX to improve the speed of their Mac networks, but rather, to put Mac servers on existing VAX hardware to take advantage of existing databases and network resources. Mac-to-VAX connections will be discussed in more detail in Chapter 9.

■ Looking Ahead

This chapter began with an exploration of Mac-based network services and ended with brief descriptions of more expensive environments for serving Macs. The next three chapters will take a closer look at exchanging data with the heavyweights of the computer world: UNIX workstations, VAXes and other minicomputers, and IBM mainframes. Mac connectivity options are not limited to communicating on the Mac's terms, via AFP. Macs can fit into the standard environments native to these platforms. We'll start small, with UNIX.

- *Exploring UNIX, Mac-Style*
 - *Exploring the X Window System*
 - *Running on TCP/IP Networks*
 - *Using NFS File Servers as AFP Servers*
-

C H A P T E R

8

The UNIX Connection



ADVOCATES OF UNIX HAVE OFTEN PROMOTED THE OPERATING system as the Esperanto of the computer world—a universal language that every computer would speak, regardless of size, shape, or brand. Although the advent of personal computers popularized DOS and Mac, two very non-UNIX operating systems, part of the UNIX ideal did come true—almost every type of computer can run one of the several standard versions of UNIX. So when you enable your Mac to communicate with UNIX computers, you open a dialog to a wide variety of computers, from large, shared computers such as Digital VAXes and Cray X/MP supercomputers, to single-user desktop workstations, such as Sun

SPARCstations and Silicon Graphics Irises. There are also UNIX-based file servers, and a good number of IBM-compatible PCs that run UNIX as well. Even the Mac can run UNIX, providing connectivity between Mac and UNIX applications on the desktop. The number of computers running UNIX is still smaller than the number of Macs, but the market continues to grow each year.

UNIX was created at Bell Labs in the 1960s as a programming environment to use in the development of AT&T's telecommunications systems. The Bell Lab scientists came up with a multiuser, multitasking system, enabling many users to share one application on a single computer, or one user to run multiple applications simultaneously. Early in the operating system's development, major additions were made at the University of California, Berkeley. These modifications, known as the Berkeley (or BSD) extensions, added some programming tools and the TCP/IP networking environment, a set of protocols originally developed by the Department of Defense for its own use and that of defense contractors. Later, Sun developed and popularized the Network Filing System (NFS) for UNIX file servers. The multitasking, multiuser, and connectivity features of UNIX (as well as an active campaign by AT&T) helped to spread UNIX throughout universities, where several generations of engineering and computer science students learned it and brought it to the corporate world.

But UNIX was not designed to be user friendly. UNIX was created specifically for programmers; the C programming language was developed along with the operating system for use with UNIX. Even DOS is user friendly by comparison with UNIX. However, the success of the Macintosh in the 1980s influenced the industry to create graphic user interfaces, or GUIs (pronounced *gooeys*) that sit on top of UNIX. These include NeXTstep from NeXT, Open Look from Sun, and Motif from the Open Software Foundation. Most UNIX GUIs use a display software standard called the X Window System developed by the Massachusetts Institute of Technology. GUIs have enabled UNIX applications to extend beyond science and engineering into such areas as graphic design and desktop publishing.

By using one or more software add-ons for your Mac, you can benefit from the information and services offered by UNIX workstations, file servers, and mainframes. These extensions to your Mac involve using many of the common UNIX operating system, networking, and graphic display standards. In some cases, a UNIX machine will appear to you as another Mac, and in other cases, you can run UNIX applications on your Mac. You can even run UNIX itself on your Mac, which is where I'll begin our lesson in MacEsperanto.

■ Exploring UNIX, Mac-Style

To the user, running UNIX on a Mac looks basically like System 7 with built-in UNIX functionality. You can run all standard Mac applications, plus UNIX programs and utilities. Having these programs side-by-side on one machine allows you to cut and paste bitmapped graphics and text between Mac and UNIX applications. You can carry this a step further if you use one of the methods described in Chapter 2 to run DOS applications on your Mac; you can then use your Mac to cut and paste bitmapped graphics and text between UNIX and DOS applications.

Running UNIX on your Mac also gives you the benefits of UNIX for UNIX applications: Your Mac becomes a multiuser machine, and UNIX applications run in protected memory. This means that one crashing application won't affect other applications running at the same time. You also get all the connectivity options built into both UNIX and Macintosh.

The standard Mac operating system by itself doesn't have any UNIX functionality, but you can purchase UNIX software for your Mac. You have two choices: Apple's A/UX or Tenon Intersystem's MachTen, both of which are solid systems that have been around for several years. Both A/UX and MachTen let you run standard Macintosh and UNIX applications.

Apple's A/UX

At the core operating system level, A/UX replaces most of the Mac operating system with UNIX. A/UX retains the Macintosh Toolbox, the code that applications use to communicate with the operating system. To ordinary Mac applications, such as MacDraw and PageMaker, A/UX looks like the standard Mac operating system. The Finder also operates just as it does ordinarily, with all the features found in System 7. UNIX applications, on the other hand, see A/UX as standard UNIX.

A/UX fully follows UNIX standards for a mainstream UNIX implementation; it's not the most advanced flavor of UNIX available, but it's not the most basic either. Version 3.0 of A/UX is compliant with the AT&T System V Interface Definition (SVID), Berkeley Software Distribution (BSD) Release 4.3, and the Portable Operating System Interface of Computer Environments, also known as POSIX. A/UX also supports TCP/IP, Sun's NFS file sharing, and the X Window System. A/UX comes with standard UNIX text editing utilities and programming libraries, including compilers and debuggers for the Assembler, C, and Fortran programming languages.

Getting A/UX Up and Running

You need pretty beefy hardware to run A/UX, which requires at least a 68030-based Mac, or a 68020-based Mac II with a 68551 PMMU (paged

memory management unit) chip. The original Mac LC cannot be fitted with a PMMU, and cannot run A/UX. You need a minimum of 8Mb of RAM to run the Installer program. If you will have multiple users, plan on having 20Mb of RAM. A/UX takes up quite a bit of hard disk space as well; Apple recommends at least a 160Mb hard disk, although A/UX can be installed on two 80Mb hard disks.

Hard drives must be partitioned into several mountable volumes for use with A/UX: a small initial boot partition of about 4Mb containing System 7, and a UNIX root partition that optimally should be at least 100Mb. Be sure to save 16 to 32Mb of hard disk space for virtual memory. With A/UX version 3.0 or greater, the Easy Install option will do the partitioning for you. You can also use the included utility Apple Hard Disk SC Setup to partition drives from Apple or third-party vendors.

A/UX comes on a CD-ROM and a floppy disk from which to boot when you install the operating system; a single button click on the Easy Install option will install the whole shebang. You can instead use the Installer to select portions of A/UX to install. However, I don't want to make it sound too easy; installing A/UX is still more complex than installing System 7.

When you boot a Mac loaded with A/UX, the small Mac partition will mount on the desktop. Double-clicking on the A/UX Startup program mounts the UNIX root partition and starts A/UX. You'll be asked to enter a user name and password, in typical UNIX fashion. In case of a system crash, A/UX automatically keeps backup files of crucial UNIX system files, which will enable you to reboot. With a successful startup, the traditional Mac desktop appears, differing only in the name of the boot hard drive, which is called /, the standard UNIX root directory.

Using A/UX

With A/UX, you have several types of environments in which to work: the standard Mac environment, several variations of command-line UNIX, and several variations of the X Window System. You can choose among these options, or run the different environments simultaneously, each in a separate window. (See Figure 8.1.)

You have several interface options for the command-line. If you haven't memorized all of UNIX's complicated commands or only use UNIX occasionally, A/UX has a command builder, Commando, that lets you click options with a mouse. UNIX traditionalists can run one of three command line interpreters, called *command shells* in UNIX lingo. Command shells act as terminal emulators linked to the heart of the UNIX operating system—the *kernel*. A/UX gives you a choice of common UNIX shells—the Bourne shell, the Korn shell, and the C shell.

Figure 8.1

Apple's A/UX 3.0 can run anything that can also be run by the Mac operating system, including QuickTime movies, plus UNIX applications.

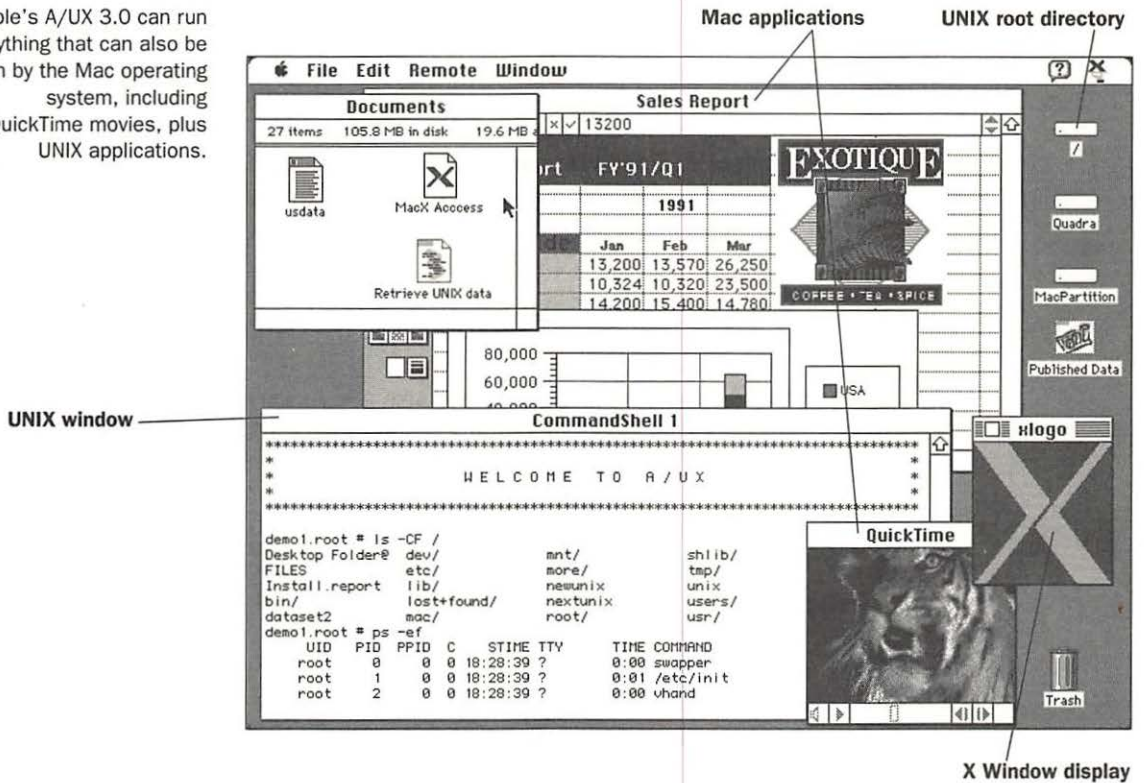

The X Window System, sometimes called X, is a graphical display standard that can have several different interfaces. A/UX gives you a choice of two implementations of X Window, X11 for A/UX and the MacX display server, both of which are implementations of the X Window System Version 11, Release 4. Of the two, X11 is geared more toward UNIX experts and software developers and includes programming tools. X11 takes over the entire Mac screen. MacX, on the other hand, gives you access to the Mac desktop and Mac application windows. MacX can also be purchased separately to run on standard operating system Macs, as discussed below. Motif for A/UX from Integrated Computer Solutions is a third-party X Window manager that implements Motif, an industry standard X interface from the Open Systems Foundation. ICS also offers a developers' toolkit for creating GUIs for the X Window System on any platform.

Communicating with A/UX

A/UX supports both standard UNIX and AppleTalk communications functions and procedures. On the UNIX side, communications span from such rudimentary functions as `cu` and `uucp` (the UNIX to UNIX copy program, for exchanging data between two nodes), to support for TCP/IP network services. Mac programs that are designed to work over TCP/IP can also use the TCP/IP functionality that comes with A/UX. Other UNIX functions include SLIP (serial link internet protocol), for establishing a serial link with another UNIX computer, and CSL/IP, which is used to establish a connection to a TCP/IP network over a serial link. Among the TCP/IP protocols supported by A/UX are `telnet` for terminal emulation, and `FTP` (file transfer protocol). A/UX also supports the more advanced file transfer protocol NFS, and can act as an NFS file server.

The standard AppleTalk abilities also add functionality not found in standard UNIX, such as selecting and printing to network LaserWriter printers and System 7's File Sharing. Interapplication communications and program linking between Mac applications will work with the TCP/IP and NFS functionality that is provided by A/UX.

The high end of desktop computing today is represented by computers running UNIX with a type of processor known as RISC, or reduced instruction set computing. The IBM RS-6000, Sun SPARCStation, and Silicon Graphics workstations offer performance five to ten times greater than the fastest personal computers.

Apple has announced that an A/UX and RISC combination will become Apple's high end of the Macintosh line and that its next major UNIX version, A/UX 4.0, will run on the PowerPC-based PowerOpen platform. The PowerPC chip is the new RISC CPU based on the IBM RS-6000 CPU and built by a joint Apple-IBM-Motorola venture. The first PowerPC Mac is scheduled to be shipped sometime in 1993. In addition to running standard Macintosh applications, A/UX 4.0 will be able to run unmodified applications written for AIX, IBM's version of UNIX for PCs.

Besides serving as Apple's top of the line Mac, the A/UX 4.0 PowerOpen Mac will most likely become Apple's file server platform for 680X0-based Mac clients, the line of today's Macs that Apple has said it will continue. An A/UX file server platform would offer some of the benefits that UNIX-based network operating systems such as Banyan's VINES already enjoy: protected memory for applications, multiuser operation, and true multitasking.

An Alternative UNIX for Mac

Tenon Intersystem offers an alternative UNIX implementation for the Mac called MachTen. Like A/UX, MachTen is a true UNIX implementation, licensed from AT&T. It gives true multitasking for UNIX applications,

supports standard UNIX communications methods, and provides a suite of UNIX programming tools (a separate developer's toolkit is also available). MachTen version 2.0 and later supports System 7 Apple events and all Apple-Talk network services.

Unlike A/UX, MachTen doesn't replace the standard Mac operating system, but rather enhances it (see Figure 8.2). Most of MachTen runs on top of the Macintosh operating system, and has its own code for virtual memory in addition to System 7's virtual memory. The result is that MachTen doesn't require you to partition your hard disk, as does A/UX, or to add special drivers for serial or SCSI devices such as fax modems and scanners. For some peripherals, A/UX requires special drivers, some of which are supplied by Apple, others of which are supplied by the device manufacturers.

Figure 8.2

MachTen is an extension to System 7, while Apple's A/UX replaces it. MachTen is compatible with more Mac models than is A/UX.

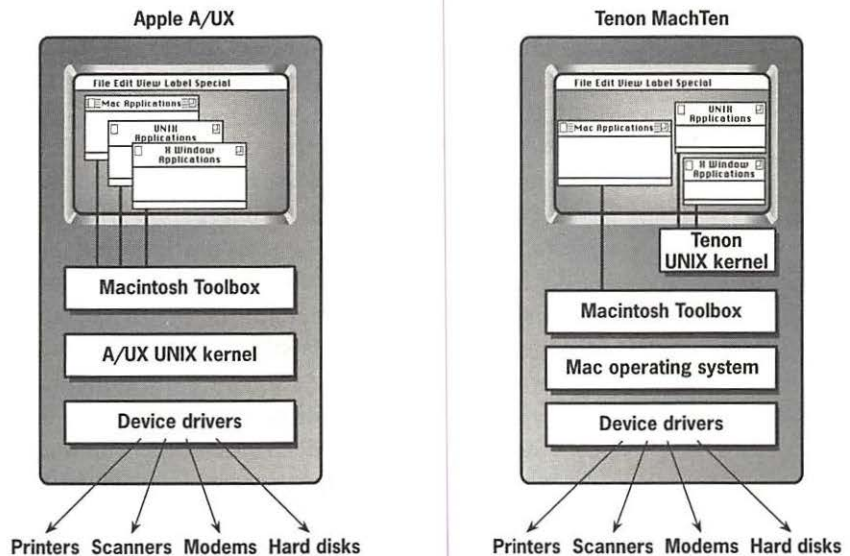

Another advantage of MachTen's approach is that it doesn't require a PMMU, so it can run on pre-68030 Macs, such as the original Mac LC, the PowerBook 100—even the old Mac SE and Plus. However, virtual memory and protected memory for UNIX applications work only on Macs with a PMMU.

To help configure your Mac, MachTen comes with the MachTen control panel from which you can set the priority of Mac and UNIX processes, as well as data caching, virtual memory, and network attributes. Tenon offers an optional X Window System package, called XTen, which includes client and server capabilities.

Like A/UX, MachTen supports the standard UNIX communications protocols, such as SLIP, SMTP (simple mail transfer protocol), and uucp, the UNIX to UNIX copy protocol, which allows UNIX machines to exchange files and mail, as well as to run programs remotely.

MachTen includes TCP/IP network functionality, which will run simultaneously with AppleTalk. MachTen supports the character-based resource sharing protocols common to the TCP/IP environment, such as SMTP for mail, telnet for terminal emulation, and FTP for file transfer. The Desktop NFS feature enables Mac applications to access NFS file servers, and mounts NFS directories on the desktop. A Mac running MachTen can become both an NFS client and server.

An Alternative Mac for UNIX

An interesting flip side to A/UX and MachTen is the technology offered by a company called Quorum Software; these products allow users to run Mac programs on certain RISC-based UNIX workstations. Applications can run in one of the standard X Window environments, such as Open Look or Motif. There are two products—Quorum Equal, for end-users, and Quorum Latitude, for software developers.

Quorum Equal enables users to run Mac software on workstations from Sun and Silicon Graphics, as well as on the IBM RS-6000, one of the fastest workstations available. It does this partly by emulating a 680x0 processor and the Mac operating system, much as SoftPC emulates DOS on the Mac (see Chapter 2). Equal also maps the Mac's 32-bit color QuickDraw display language into the Display PostScript language used on workstations.

Quorum Latitude allows software developers to port their Macintosh programs to RISC workstations with a minimum of rewriting. Latitude automates the recompiling of Mac source code into native UNIX executable code, which means that Mac programs ported with Quorum Latitude will run faster than Mac programs run with Equal. With both Equal and Latitude, the Mac applications run in protected memory mode. This is not true for either A/UX or MachTen, which only support protected memory for UNIX applications.

However, Quorum is not as complete an implementation of the Mac as A/UX is of UNIX. For instance, Quorum maps Mac application features to UNIX, but many of the Mac operating system features are not carried over to UNIX. For example, Quorum does not support interapplication communications features, such as program-linking and Publish and Subscribe. It doesn't support Apple events, so features that use Apple events with a Mac application won't work on the UNIX machine. Quorum also does not support Apple's Data Access Language (DAL), used by applications to connect databases running on different computers (DAL will be covered in Chapter 11).

AppleTalk is also not supported. Quorum says that future versions of its products will more fully support System 7 features.

■ Exploring the X Window System

The X Window System, also called X, is a windowing standard developed by a group called the MIT X Consortium. X enables a workstation running UNIX, a character-driven command-line OS, to run graphics software that can be controlled with a mouse. X can also be used over a network, similar to the way Argosy's RunPC works (discussed in Chapter 2). An application with a graphic interface appears in a window on your machine, but most of the processing is done elsewhere on the network. With X, the processing could be on a UNIX workstation or on a VAX minicomputer over a TCP/IP, DECnet, or AppleTalk network. The processing for the interface is done on your Mac.

The terminology used with the X Window System can be confusing. The terms *client* and *server* are used in exactly the opposite way that the terms are used in describing other network services. When you're speaking of files, databases, or printing, the server is the software running on the shared computer, while the client software sits on the users' machines. In X-speak, it's the shared computer that runs the client software, which users can access over a network. The X server, or *display server*, is software that always runs on the user's machine (see Figure 8.3). (A user can also run both server and client software on a local computer.) The display is considered a server because it is shared by applications running on other machines on the network.

The display server only displays; the processing is done by the client. The client software is hardware independent: It doesn't care what brand of machine the user is running. The server software is hardware specific: It knows how to display information only for the specific workstation or terminal that is receiving information from the client.

One more piece of software is used to put windows on command-line UNIX—the window manager. The window manager determines the exact interface details of the X window—what the scroll bars look like, how the windows are resized, and how various icons act. Products such as Open Look from Sun and Motif from the Open Software Foundation are window managers; they determine the exact look and feel of the interface. Applications are usually written for a specific window manager, although some have the capability to switch between window managers.

I mentioned earlier that A/UX running on a Macintosh comes with two choices of X display server software: MacX or X11, with the additional option of purchasing Motif from a third party. Fortunately, you don't have to be running A/UX to run the X Window System. Macs using the standard

Mac operating system can use the X Window System to access UNIX or VAX X clients; doing this puts a UNIX application in a window on your Mac. X server software for your Mac lets you tap into the computing power of a more powerful UNIX machine and cut and paste between Mac and X applications. There are also X client packages for the Mac that let UNIX users run Mac software from their Mac in a window on their workstations. These will be discussed a little later on.

Figure 8.3

In the X Window System, the *client* runs the application and the *server* sits on the user's machine.

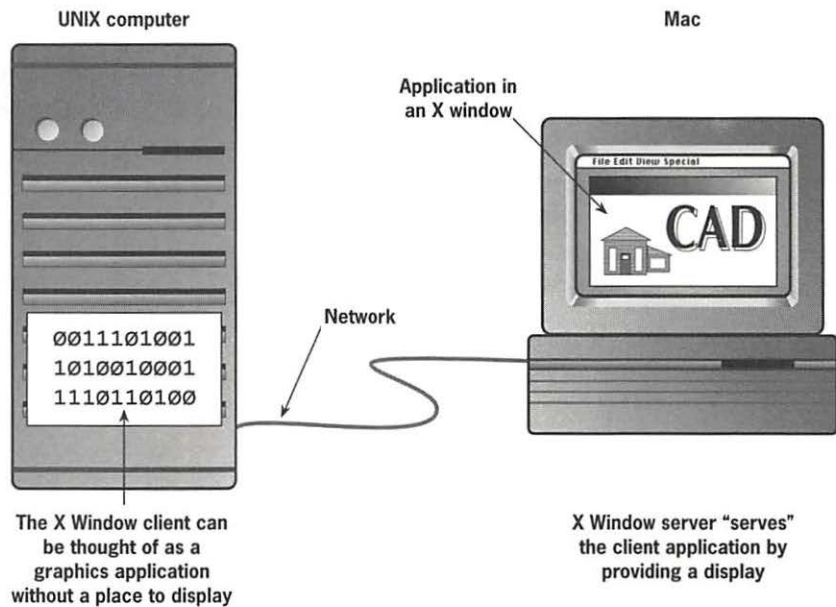

Mac X

Apple's MacX is an X Window display server that will run on System 6, System 7, or A/UX. MacX displays one or more X windows inside of a standard Mac window (see Figure 8.4). MacX provides both the X display server and the window manager. This gives the X windows a very Mac-like look and feel, including the standard Mac interface elements such as title bars and close boxes. MacX also supports foreign window managers, such as Motif or twm, short for Tom's Window Manager, a public domain package. Motif is considerably less Mac-like than the MacX window manager, and more closely resembles Microsoft Windows than the Mac. MacX also supports DECWindows for use with Digital's VAX computers.

MacX works in 8-bit color and gray scale, and comes with a large assortment of special X Window bitmapped fonts; the X Window System cannot

use ordinary Macintosh fonts. MacX includes MacTCP for use with TCP/IP networks, but can also be run over DECnet and AppleTalk. Although MacX will work over LocalTalk, Apple recommends that Ethernet be used, since a lot of display update information is passed over the network during an X Window session.

Figure 8.4

MacX software makes an X display server from a Mac window, enabling you to run UNIX applications in a window on your Mac.

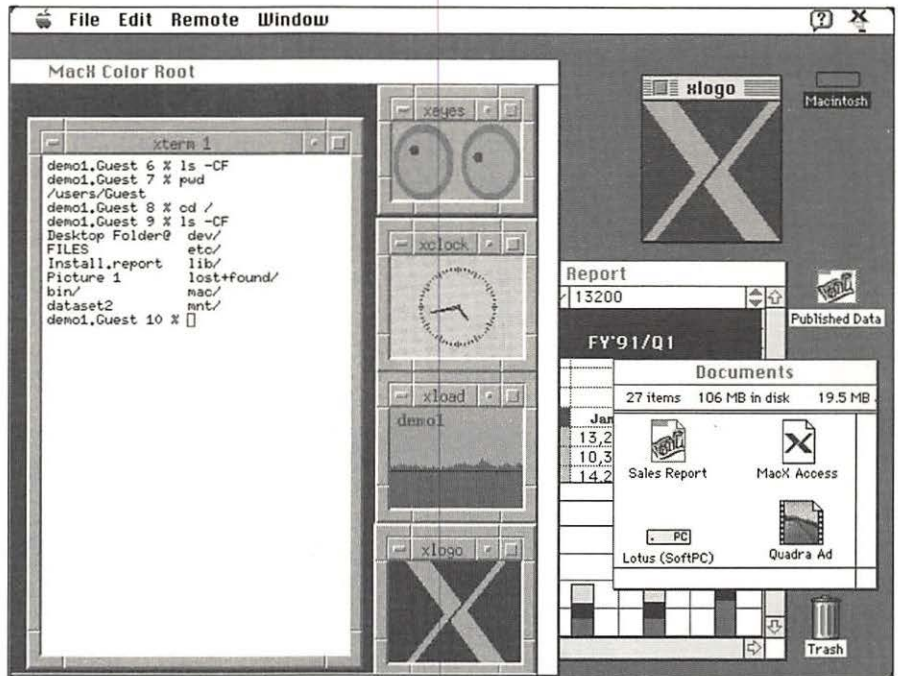

eXodus

White Pine Software's eXodus is an alternative X Window System server that is very similar to MacX. Both packages support both *rootless* windows, which can be moved around the desktop like standard Mac windows, and *rooted* windows, in which all other X windows are run inside the first window similar to the way Microsoft Windows works. EXodus will work over TCP/IP and DECnet networks.

Like MacX, eXodus comes with a window manager, called eXene (after the lead singer of the rock group X from the early 1980s). EXene provides a Mac-like window, as well as an option to produce a Motif-like window. The Mac window—with well-designed menus and easy-to-use scripts—is more elegant than the window in MacX. Because of this careful design, it's easier to establish a connection to X client software using eXodus than with MacX.

However, eXodus requires more memory than MacX—2Mb, as opposed to under 1.5Mb for MacX. In addition, MacUser Labs testing has shown that eXodus is about 15 to 20 percent slower than MacX. Both programs are slower than the X11 X Window server that comes with A/UX. This is because X11 uses its own X screen redrawing techniques instead of the Mac's QuickDraw routines.

Client X Window for Your Mac

So far, I've been discussing running X display server software on your Mac. You can also install X client software for the Mac, which allows applications running on your Mac to be displayed on UNIX workstations running X display servers. The use of Macintosh X clients can lead to the unusual situation of a Macintosh program running in a very un-Maclike window on a UNIX workstation (see Figure 8.5). It is also possible to install X client and server software on two Macs, but products such as Farallon's Timbuktu or Micro-Com's Carbon Copy Mac will be faster and more convenient to run Mac applications remotely.

Figure 8.5

XGator puts a display client on your Mac, allowing a UNIX workstation user to run a Mac application in a window.

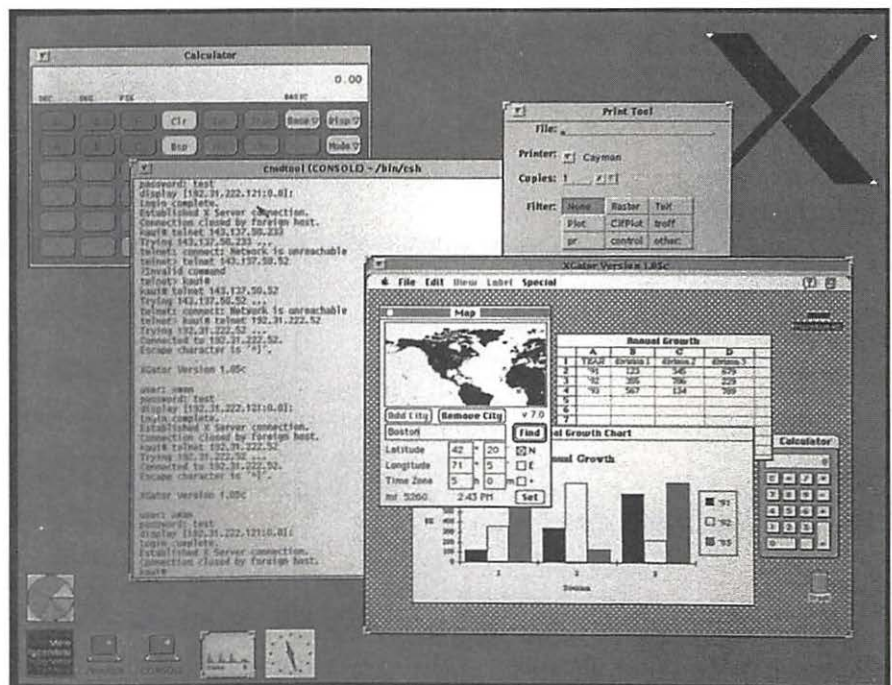

Two Macintosh X clients are available, XGator from Cayman and Planet X from InterCon. With either package, users on UNIX workstations will experience performance far below what they are used to. The Macintosh, which is running the application, is simply a slower machine than most UNIX workstations. However, the main reason for slow Macintosh X client performance is that the X client software available for the Mac is slower than X server Mac software. This is because MacX and eXodus only send screen update information in the form of commands, while the Macintosh X clients send bitmaps of the screens—which is a lot of data. The more graphic-intensive the application, the slower the performance.

A faster alternative to using X clients for the Mac is to use Quorum, the UNIX software that allows Mac applications to run on UNIX computers. The X Window solution is more flexible, however, because Quorum will run on only a handful of UNIX workstation models. The Mac X clients will work with any UNIX machine loaded with X display server software.

■ Running on TCP/IP Networks

Your Mac doesn't have to run UNIX in order to communicate with UNIX workstations, minicomputers, and mainframes. Macs running the standard Mac operating system can participate on networks using TCP/IP (Transmission Control Protocol/Internet Protocol), the network standard used on most UNIX computers. TCP/IP is the de facto standard for large networks that consist of different types of computers. For Macs, TCP/IP is an alternative to AppleTalk. However, TCP/IP is not as self-configuring as AppleTalk, and is definitely not a plug-and-play network; it takes a fair amount of technical knowledge to set up even a small network.

TCP/IP predates AppleTalk by a decade, originating in the Defense Advanced Research Projects Agency (DARPA), part of the Department of Defense. TCP/IP was developed to operate at high throughput rates on very large internets of thousands of computers of different types. In addition to being used at universities and in government, TCP/IP is important in enterprise-wide corporate computing environments, where large mixed networks often use TCP/IP on the major backbones. By tunneling foreign networks through TCP/IP, a process described in Chapter 6, branches of a TCP/IP backbone can consist of networks of AppleTalk, DECnet, and other network protocols.

The reason TCP/IP can handle so much more traffic than AppleTalk can is that it has less protocol overhead than AppleTalk. This is partly because AppleTalk is dynamically configured, and TCP/IP is statically configured. For instance, AppleTalk nodes negotiate over the network to establish node IDs; TCP/IP ID numbers are all set by a network administrator. As was discussed

in Chapter 6, AppleTalk routers constantly update each other as to their status. In an IP environment, however, the network administrator must reconfigure a network whenever a router is added.

Macs on TCP/IP

The Mac's involvement with TCP/IP started with developments at Stanford and Columbia Universities. Before the invention of Apple's EtherTalk, when AppleTalk could be transmitted only over LocalTalk, Stanford UNIX developers devised a way for Macs to use Ethernet—by encapsulating AppleTalk packets within TCP/IP. When a now-defunct company called Kinetics came out with the first LocalTalk-to-Ethernet router, FastPath, the Stanford protocol was ported to it and called the Kinetics Internet Protocol, or KIP. (Kinetics was bought by a company called Excelan; Excelan was then acquired by Novell, who sold the FastPath product line to Shiva, the current developer and marketer.)

Shortly after the invention of KIP, developers at Columbia came up with CAP, the Columbia AppleTalk Package, a freeware bundle that included KIP, a utility to enable Macs to access UNIX file servers, and a print spooler. Because KIP and CAP are in the public domain, they still can be found in use at some universities. However, they are not recommended for use in today's networks, because KIP is not completely compatible with AppleTalk Phase 2. Some modern AppleTalk-IP routers, such as Shiva's FastPath and Cayman's GatorBox, will support KIP, but use a more modern protocol to handle most traffic between the two types of networks. Shiva calls the modern protocol IPTalk; other companies often call it kip-like routing. More recently, Apple came up with the AppleTalk Update Routing Protocol (AURP) for encapsulating AppleTalk over wide-area networks. (AURP will be discussed in detail in Chapter 13.)

These days, Macs have other choices for TCP/IP connectivity, in addition to AppleTalk encapsulation. With the installation of MacTCP, a small TCP/IP driver from Apple, Macs can participate as full TCP/IP nodes. MacTCP enables Mac communication and file sharing over TCP/IP networks. MacTCP can run simultaneously with AppleTalk, giving Mac users access to AppleTalk as well as to TCP/IP network services. UNIX programs running under A/UX, or TCP/IP-aware programs running under the Mac OS can take advantage of the network. MacTCP runs over Ethernet, token ring, and LocalTalk.

An alternative to installing MacTCP in every Mac is to add a gateway between TCP/IP and AppleTalk networks. This is a slower way for a Mac to communicate with a UNIX node than is MacTCP, but is easier to administer for large numbers of Macs. Gateways can often translate higher network functions, such as file sharing and electronic mail, between the UNIX

and Mac environments, so that the services appear in their native format for each platform.

Standard TCP/IP Services

Several sets of standard TCP/IP network and communication services are available to UNIX machines. These services, mentioned in the above sections on running UNIX on the Mac, include terminal emulation, file transfer, and electronic mail.

With the use of special software, TCP/IP services are also available to Macs and PCs running non-UNIX operating systems on TCP/IP networks. The services are often grouped together in packages. These packages are aimed mostly at the experienced TCP/IP or UNIX user, since the services are presented in a text-based format. InterCon's TCP/Connect II is a popular package with a full range of UNIX services (see Figure 8.6). TCP/Connect II also offers network management through the simple network management protocol, SNMP, which will be discussed in Chapter 12. NCSATelnet is a similar public domain program with a smaller feature set.

Figure 8.6

Mac users can access standard TCP/IP services with software such as Intercon's TCP/Connect II.

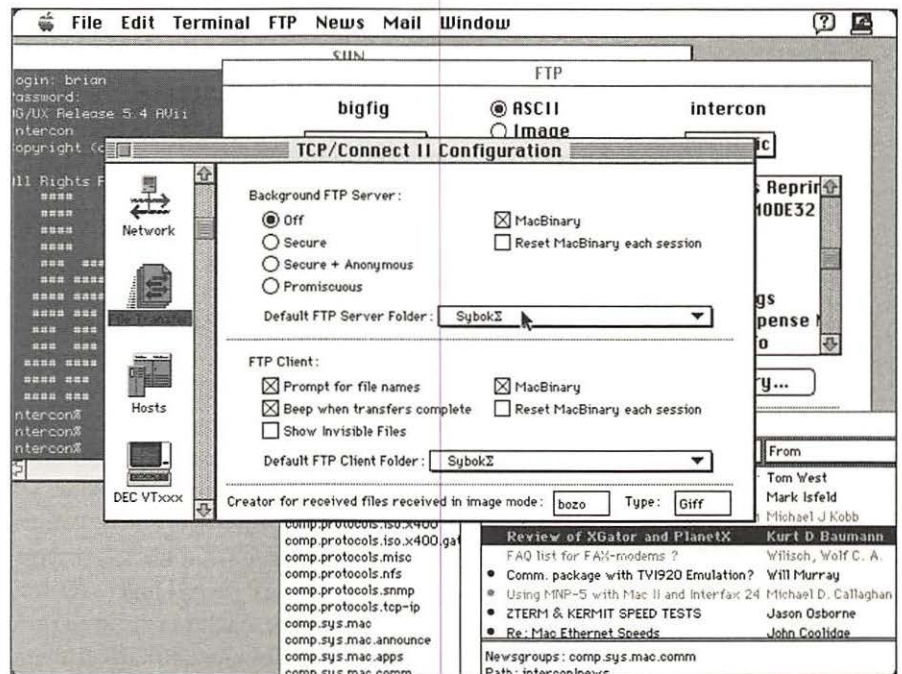

One of the ways computers running UNIX can support multiple users is through the use of video display terminals, which consist of a monitor and keyboard, but no processing abilities. *Terminal emulators* are programs that act as terminals on intelligent computers such as Macs and PCs. TCP/IP terminal emulation differs from the terminal emulation features of telecommunications packages mentioned in Chapter 3 in that the emulation occurs over a network instead of over a modem. The TCP/IP protocol that facilitates network terminal emulation is called telnet. A telnet link is sometimes referred to as a virtual terminal connection. TCP/Connect II and NCSATelnet both provide telnet capabilities, as do the VersaTerm-PRO and PacerTerm terminal emulation programs. VersaTerm-PRO also supports SLIP terminal emulation.

TCP/IP file transfer and electronic mail are conducted with two protocols, FTP (file transfer protocol) and SMTP (simple mail transfer protocol), which are both basic services. One of the features of SMTP is that its commands are the same regardless of what machine is the host. TCP/Connect II contains SMTP capabilities. Intercon also offers Dispatcher/SMTP, electronic mail gateway software that allows Mac users to use CE Software's QuickMail to access SMTP users.

The TCP/IP Internet

A Mac running MacTCP or connected to a TCP/IP network with a gateway can connect to the TCP/IP Internet, a giant network of connected local and wide-area networks conservatively estimated at connecting 60,000 computers across the country. The numbers of occasional private users connected through gateways is estimated to be in the millions worldwide. Member networks are some of the early adopters of UNIX, including DARPA's ARPANET, the National Science Foundation's NFSNet, the Department of Defense's MILNET, as well as many universities and businesses.

The TCP/IP Internet can be used to connect private networks in different locations across the country. Public networks, such as Telenet or Tymnet, can be used for this purpose. Open file servers on the Internet contain all of the public domain UNIX and TCP/IP software mentioned in this chapter, as well as much more. The Internet is also a good way to reach by electronic mail someone in industry, academia, or government.

To participate in the Internet using your Mac, you'll need MacTCP installed or a dedicated AppleTalk-to-TCP/IP gateway. Your network can connect via a wide-area link (see Chapter 13) or you can connect individually over a phone line with SLIP (serial link internet protocol). With so many computers on a single network, each machine requires a unique 32-bit identifying number. Interested parties can call Government Systems, Inc. at (703) 802-4535 for an application for an Internet network ID number.

■ Using NFS File Servers as AFP Servers

Although TCP/IP provides simple file transfer between nodes, no file sharing or file service is provided. To fill this gap, Sun Microsystems developed the NFS (Network Filing System) protocol, which has been widely adopted as a de facto file server by UNIX vendors. NFS is roughly equivalent to AppleTalk's AFP protocol, so it's not surprising that there is a range of products available to allow Macs to access NFS servers residing on UNIX computers. Unlike other UNIX network standards, which require you to know how they work, access to NFS from a Mac is usually through the standard AFP interface, the Chooser. Like any other AFP volume, a UNIX NFS file server becomes an icon mounted on the Mac desktop.

There are four basic strategies to enable Macs to access NFS file servers (see table below). You can add software on a Mac to enable it to read NFS; you can add software to a UNIX host to turn it into an AFP server; you can add an AFP-NFS gateway; or you can use a third network protocol system that is foreign to both Mac and UNIX, such as Banyan VINES or Digital Equipment Corporation's PathWorks.

Method	Pros	Cons	Best Use
Software on Mac client	Easiest to install; access to any NFS server	Difficult to maintain with large numbers of Macs	Small number of Macs with one or more NFS servers
Software on UNIX server	Easy to maintain for large numbers of Macs; good performance	Difficult to install; limited to a few UNIX machines	A mostly Mac LAN or workgroup; as an AppleShare alternative
AFP gateway	Access to any NFS server; easy to maintain for large numbers of Macs	Slow performance; central point of failure	Networks with many Macs and multiple NFS hosts
3rd protocol	Access to any NFS server; access to multiple OS and network services	Most expensive; complex system to maintain	Mixed PC, Mac, UNIX environments

Macs and NFS

The simplest way to give a single Mac access to NFS is to install software that enables the Mac to read NFS packets and translate them to AFP packets (see Figure 8.7). Installation involves dropping a small NFS driver file into the System Folder and entering a node address. The NFS server directories can then be mounted on the Mac desktop. This is the most economical solution for a small number of Macs. With a large number of Macs, the cost per node is higher than the more centralized approaches described below. This method of NFS-enabling for Macs is also harder to manage with lots of nodes than a centralized solution. However, it does allow Macs to access multiple NFS servers, regardless of what computer they are running on.

Figure 8.7

NFS software on the Mac can translate NFS signals from any type of NFS server on the network. Nothing needs to be added to the UNIX machines.

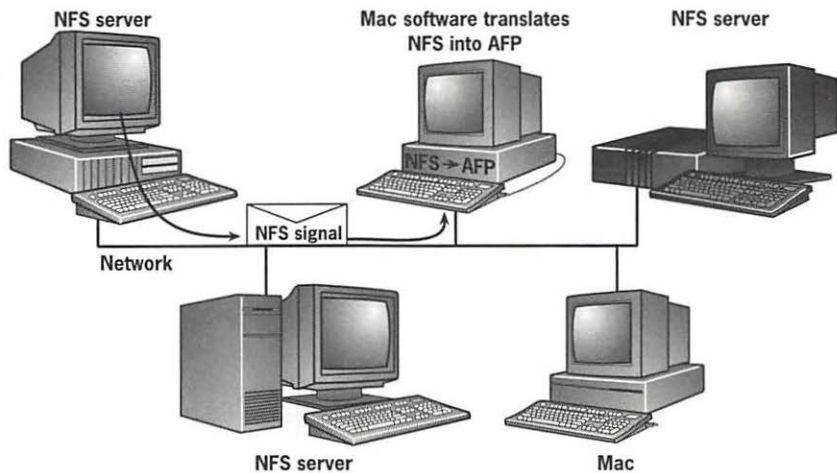

Wollongong's Pathway Client NFS is one such product, and can be used with either MacTCP or a TCP/IP-AppleTalk gateway. A control panel is used to enter the server and client information needed to access one or more servers. Bundled with Pathway Client NFS is a print server that lets UNIX computers print to laser printers on LocalTalk. The LRP Print Server is a background application that can run on any Mac.

Another product is NFS/Share from InterCon. One nice feature of this package is that System 7 users can set access privileges on NFS directories using the Mac's Sharing command in the File menu; System 6 users can use the Get Privileges command. NFS/Share does this by mapping Sun's NIS and BW-NFS protocols to AFP access privileges. The NIS protocol is used for authentication of user IDs. NFS/Share allows the Mac user to see the name of the owner of a directory (folder) instead of an ID number.

NFS/Share also allows you to use the System 7 trick of putting an alias of an NFS volume on a floppy disk and then accessing it from any Mac on the network with a double click of the alias. With NFS/Share, an alias can reach out across the TCP/IP Internet and mount a remote NFS server. You must have a direct connection to a TCP/IP network in order for the trick to work. Serial connections using the SLIP protocol are not supported.

UNIX Hosts as AFP File Servers

You can turn NFS file servers into AFP file servers by installing software on the UNIX hosts that enables them to send out AFP packets. No software needs to be added to the Macs, which just use the standard AppleShare client software that comes with the Mac operating system (see Figure 8.8).

Figure 8.8

Running AFP software on the NFS server allows a network full of Macs to use it as an AFP server without having to add Mac software.

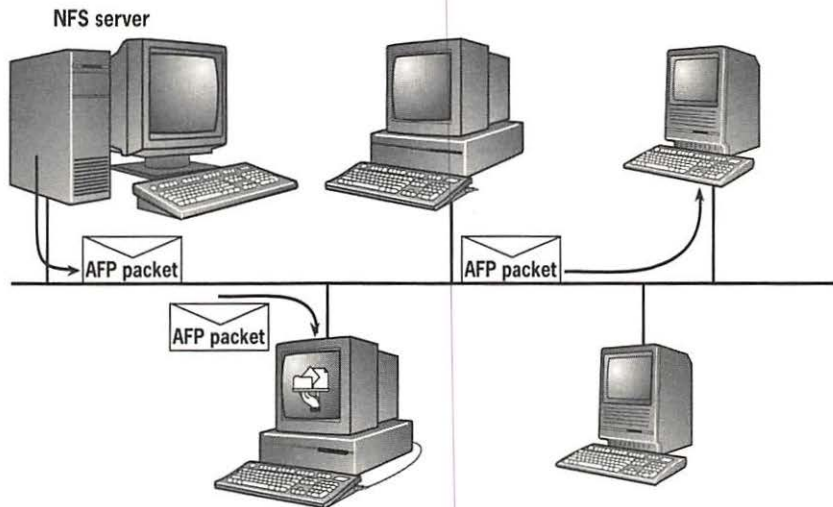

Installation is more complicated than dropping a small file into a Mac's System Folder—it requires low-level rebuilding of the UNIX operating system kernel. This must be done by someone who knows his or her way around the UNIX operating system. Because the software is installed at such a low level, this method is highly specific to the make and model of the host machine. The distributed approach (adding software to individual Macs) discussed in the previous section has the advantage of enabling the Macs to read any NFS file server on the network, regardless of the hardware's manufacturer and model. However, the host software approach is much easier to manage and upgrade for a large number of Macs, and any number of new Mac clients can be added without the need to add and configure any Mac software.

XiNET's K-AShare (formerly from Mt. Xinu) is AFP server software that runs on UNIX workstations from Silicon Graphics, Sun, and Hewlett-Packard. The workstation does not have to be dedicated to the task of file serving, which will run as a background task on a user's workstation. Remember, UNIX is a true multitasking operating system, so the file server task will be protected from other tasks running on the workstation.

K-AShare uses AppleTalk network protocols for communications between Macs and the UNIX host. TCP/IP can also be used on the network if the UNIX host needs it for other purposes. K-AShare is also offered with K-Spool, a spooler for the UNIX host that lets UNIX users access AppleTalk laser printers.

UShare from Information Presentation Technologies is a similar product that runs AFP file servers on Sun and NeXT workstations. UShare runs on AppleTalk and TCP/IP; an optional LocalTalk network interface board is offered for Sun workstations. A print spooler is offered that makes both Macintosh and UNIX printers available to UNIX and Mac clients. Other options include telnet terminal emulation, SMTP and Sun SendMail, and an administrator's package that can be accessed from a Mac.

Another product from IPT, a superset of UShare called Sun Partner, is a bidirectional, peer-to-peer file-sharing setup between Macs and Sun SPARC-Stations. Sun Partner puts Macs and Suns on equal footing by giving Suns running OpenLook access to shared Mac folders, such as AppleShare or those made available to the network with System 7's File Sharing. To the UNIX users, AFP volumes look like NFS directories and can be mounted on the OpenLook desktop. Sun Partner adds to the Sun workstation a Chooser-like device called NETFinder, which can be used to pick a Mac file server or printer. UNIX users can also opt to use the native UNIX interface.

At least one UNIX host doesn't have to be taught how to act as an AFP server; Sony offers an AFP file and printer server option for its NEWS RISC-based workstation. Sony's software is based in part on IPT's UShare. Sony NEWS workstations have built-in support for AppleTalk over Ethernet.

Mac-to-UNIX Gateway

Just as you can use a gateway to translate low-level TCP/IP and AppleTalk signals, you can rely on gateways to translate AFP and NFS signals as well. In this case, you don't add any software to either the Mac or the UNIX host; all the software runs on the gateway, which is usually a stand-alone piece of hardware. Additional software is sometimes offered to add translation of print and mail services between the Mac and UNIX environments.

The gateway solution is the easiest one for the largest network setups, in which there are many Mac clients, and multiple UNIX computers as well. The software is not specific to individual UNIX machines, but will work for

any NFS hosts. No additional software needs to be added for either new Macs or UNIX hosts, and upgrades for any number of Macs or hosts occurs in a single spot: the gateway (see Figure 8.9). This also makes the gateway a central point of failure, but you can get around this to some degree by configuring multiple gateways. Be aware, however, that gateway performance can be up to twice as slow than if you added software to the host or clients.

Figure 8.9

NFS to AFP translation can occur in a TCP/IP-AppleTalk gateway.

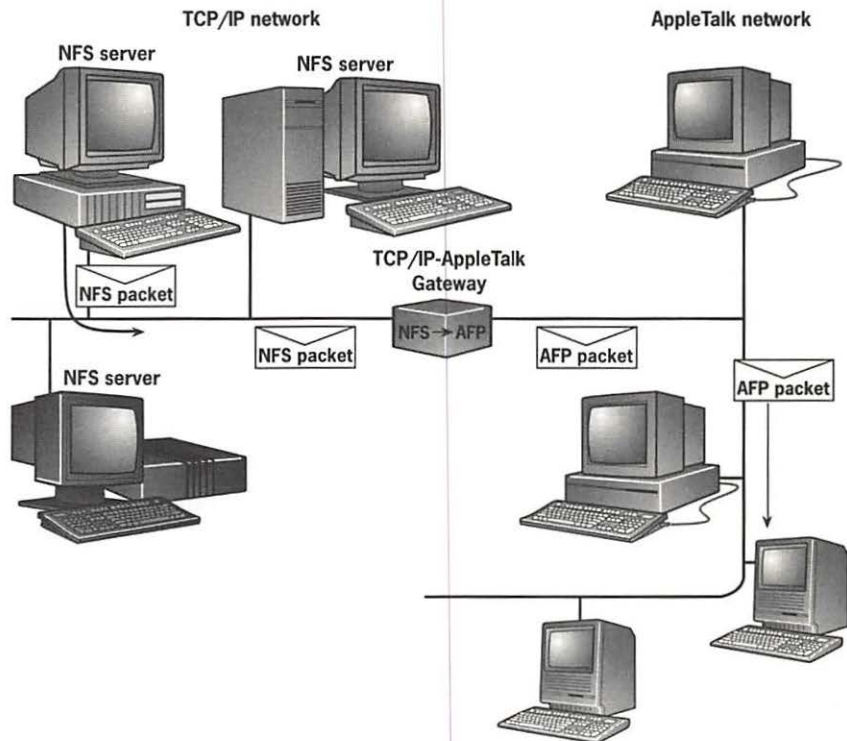

Cayman's GatorBox is a router/gateway with software modules for different gateway functions. The GatorStar, which is the GatorBox with a built-in star hub, increases performance. The GatorStar is also available as a plug-in hardware module for Cabletron's multihub concentrators. Cayman's software offerings for the GatorBox include GatorShare software for AFP-NFS translation. GatorPrint for print serving provides UNIX workstations access to AppleTalk laser printers. GatorMail provides translation between SMTP hosts and QuickMail and Microsoft Mail. Network management of the GatorBox is available through telnet terminal emulation.

The Third Protocol

The final method of using NFS hosts as AFP servers is also a gateway approach, but instead using a direct AppleTalk-to-TCP/IP, AFP-to-NFS gateway, each side communicates with a third set of protocols, such as the Banyan VINES network operating system described in Chapter 7, or Digital's PathWorks, described in Chapter 9. This type of setup has both the Mac and UNIX speaking with a non-native protocol, and facilitates the addition of other platforms—both clients and servers—to the shared environment (see Figure 8.10).

Figure 8.10

A third file server protocol can act as a middleman between NFS and AFP, integrating a PC network in the process.

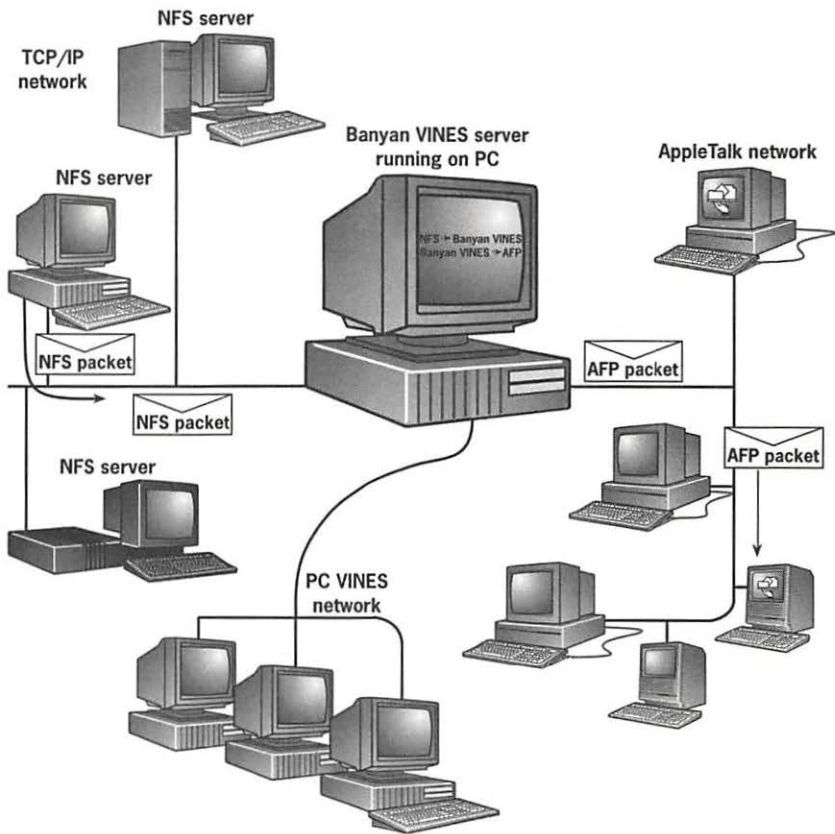

This is a practical solution for sites with a large existing PC base that are adding UNIX and Macs. The third protocol approach is also the most expensive solution of the four described in this section.

■ Looking Ahead

UNIX computing represents bigger computing than Macs and PCs: It is more powerful, its hardware and software are more expensive, and it requires more technical knowledge to set up and run. Yet Macs and PCs, which grew up as alternatives to the centralized computing of big computers, benefit from their ability to treat these bigger machines as resources. This benefits an entire organization, which may need big computers to hold vast arrays of database information that is vital to a company's day-to-day operations.

Of course, UNIX is not the last word in big computing; other important operating systems exist as well. One of the most important is Digital Equipment Corporation's VMS, which runs on Digital's VAX line of minicomputers. Both Apple and Digital saw the importance of integrating the Macintosh and VAX worlds, and put their heads together in a much-ballyhooed strategic alliance. The resulting products, described in the next chapter, were much less hyped, but were more important than any corporate coalition.

- *Built In: The Communications Toolbox*
 - *VAX and Mac Networking*
 - *VMS Application Access*
 - *The VAX as a Mac File and Print Server*
 - *VAX Electronic Mail Servers*
-

C H A P T E R

9

The VAX Connection

BIG COMPUTERS—SHARED MACHINES THAT ARE DECIDEDLY non-desktop in nature—offer much to their users in the form of huge data storage capacities, lots of processing power, and high data security and reliability. One of the most important kinds of big computers with which to share data is the VAX line of computers, from Digital Equipment Corporation. VAXes are often used to run corporate-wide enterprise applications and to store large databases of millions of records. Being able to tap into this resource from your Mac is an advantage. Fortunately, Apple and Digital have worked together to provide the framework for a rich set of tools that integrate Mac and VAX environments.

In addition to offering added power, the VAX is important to Macintosh connectivity because there are a lot of Digital's computers around—this venerable company has been selling computers since 1957. Throughout much of its history, Digital has prospered by offering what are often called *minicomputers*, cheaper alternatives to large mainframes. Although mainframes often require an entire room, Digital's minicomputers fit nicely into a corner of a room, and cost tens and sometimes even hundreds of thousands of dollars less than mainframes. Digital's first minicomputer, the PDP-1, began the PDP line of computers that lasted for almost 20 years—an aeon in a rapidly evolving world of computer technology. In 1977, Digital introduced the VAX line, the VMS operating system, and the DECnet network protocol suite to connect the machines together. Although VMS is still the primary operating system, the VAX can also run ULTRIX, a System V compatible version of UNIX, to which many of the connectivity issues discussed in Chapter 8 apply.

Since the first VAX, Digital has produced an assortment of large and small VAX systems. These include the VAXcluster, a system of connecting 16 separate machines to act as a single processing unit, and the MicroVAX, a server that is no bigger than a Mac. Digital also offers a line of desktop computers that runs UNIX and OS/2. In fact, the proliferation of desktop PCs has caused Digital to shift its focus from providing small mainframes to providing large servers for workgroups of desktop machines—one of which is the Macintosh. The shift has been away from a host-terminal paradigm to a client-server model (as discussed in Chapter 7). Instead of all the processing being done on the VAX, many of the applications run on the clients, which are desktop computers connected to a network of servers and clients with Ethernet. This scheme may sound obvious, but is very different from the way IBM mainframes work with desktop computers.

You can still use your Mac to access a VAX through terminal emulation, of course. All it takes is some software on the Mac, and you can run VMS applications, perform file transfers, and access other services. Terminal emulation is simple to set up, but requires the user to know how VMS works. A similar strategy is to run the X Window System, which is easy and inexpensive if the VAX already has X Window software and applications running on it. Many companies are taking their enterprise-wide information systems even further towards the client-server model, using applications on the clients to access data on the server. Making a Mac a full client to a VAX server is more costly than terminal emulation and requires installation of software on the VAX host, but enables Mac users to interact with the VAX using the Chooser and familiar-looking Mac applications.

Built In: The Communications Toolbox

System 7.0 or later contains an embedded operating-system feature called the Communications Toolbox (System 6 users can add it to their System Folder). The Communications Toolbox allows a communications application to use different types of links, such as serial, modem, or network. By dropping a Toolbox file into the System Folder, you can also add new functions to some of your connectivity software, while providing the same user interface regardless of the type of connection.

The Communications Toolbox is used only by those programs that have been written specifically to make use of it. Although Apple designed the Communications Toolbox for all sorts of communications over networks and telephone lines, the vendors of VAX connectivity products are the ones who have made the most use of it. Throughout this chapter, I'll cite examples of important Mac-to-VAX connectivity products that make use of the Communications Toolbox.

For the user, the power of the Communications Toolbox is the ability to configure Communications Toolbox-compatible applications by adding or removing files called *tools* for specific types of connections and functions. Communications tools dropped into the System Folder under System 7 will automatically be placed where they belong, in the Extensions Folder, the Control Panels folder, or at the top level of the System Folder. System 6 users add communications-tool extension files to a special Communications Folder, which appears in the System Folder after Apple's installation disk has been run. Both Apple and Digital, as well as other developers, have developed a suite of tools for the Toolbox. The standard set of tools usually comes with the connectivity software sold by third-party developers.

There are three types of tools—connection, terminal, and file transfer. Connection tools establish the connection between a Mac application and a host using a particular connection media. A Communications Toolbox application will work over any type of connection if you have the corresponding connection tool in the System Folder. The LAT tool, for instance, implements Digital's LAT (local area transport) technology—a high-speed, asynchronous communications link for terminals through networks, similar to UNIX Telnet on TCP/IP, described in the last chapter. (Communications that are *asynchronous* have no timing of the intervals between signals.) The CTerm tool takes LAT a step further, enabling terminal emulation over a wide-area network. The ADSP tool is the AppleTalk counterpart to LAT and Telnet, providing a direct connection to a VAX running AppleTalk software, such as Digital's PathWorks.

File transfer and terminal tools provide additional functions to a communications application, regardless of the type of connection (see Figure 9.1). Terminal tools determine the type of video display terminal emulated by your Mac. Your communications program doesn't have to know how to emulate specific terminals, but will work with the tools in the Communications Toolbox. File transfer tools provide drivers for standard file transfer protocols, such as FTP and Xmodem.

The Communications Toolbox gets its name from a convention of the Macintosh operating system. Toolboxes in the Mac OS are application-programmer interfaces (APIs) to which software developers enable their software to communicate. The Communications Toolbox provides a single API to developers. This means that any application written to the specifications of the Toolbox can take advantage of any tool the user adds to the System Folder. This saves developers from having to write specific functions into their programs. This is not only useful for creators of commercial products, but for in-house developers as well. Developers can also create their own Communications Toolbox tools.

■ VAX and Mac Networking

Establishing a network connection to a VAX can be accomplished by running your Mac and/or the VAX on one or more of three network systems: DECnet, AppleTalk, and TCP/IP. DECnet is a collective name given to the software and hardware products that implement the Digital Network Architecture (DNA). Just as AppleTalk defines the protocols and hardware used in the Mac's native network, DNA is the VAX's native network architecture for VMS. (Digital uses two terms to distinguish between the network architecture and networking products; the word *AppleTalk* is usually used to describe both the network architecture and the networking products.) TCP/IP is the industry-standard network generally used with networks of UNIX computers. Figure 9.2 is a summary of the network options in Mac-to-VAX connectivity.

Running DECnet, AppleTalk, or TCP/IP networks on Macs and VAXes can be accomplished in a variety of ways, all of which involve adding software to one or both machines. Putting a Mac on a TCP/IP network was discussed in Chapter 8; I'll now discuss putting a Mac on DECnet and a VAX running VMS on AppleTalk.

Figure 9.1

Tools in the Communications Toolbox allow an application to communicate with a host through one of several types of links and provide an application with terminal emulation and file transfer capabilities.

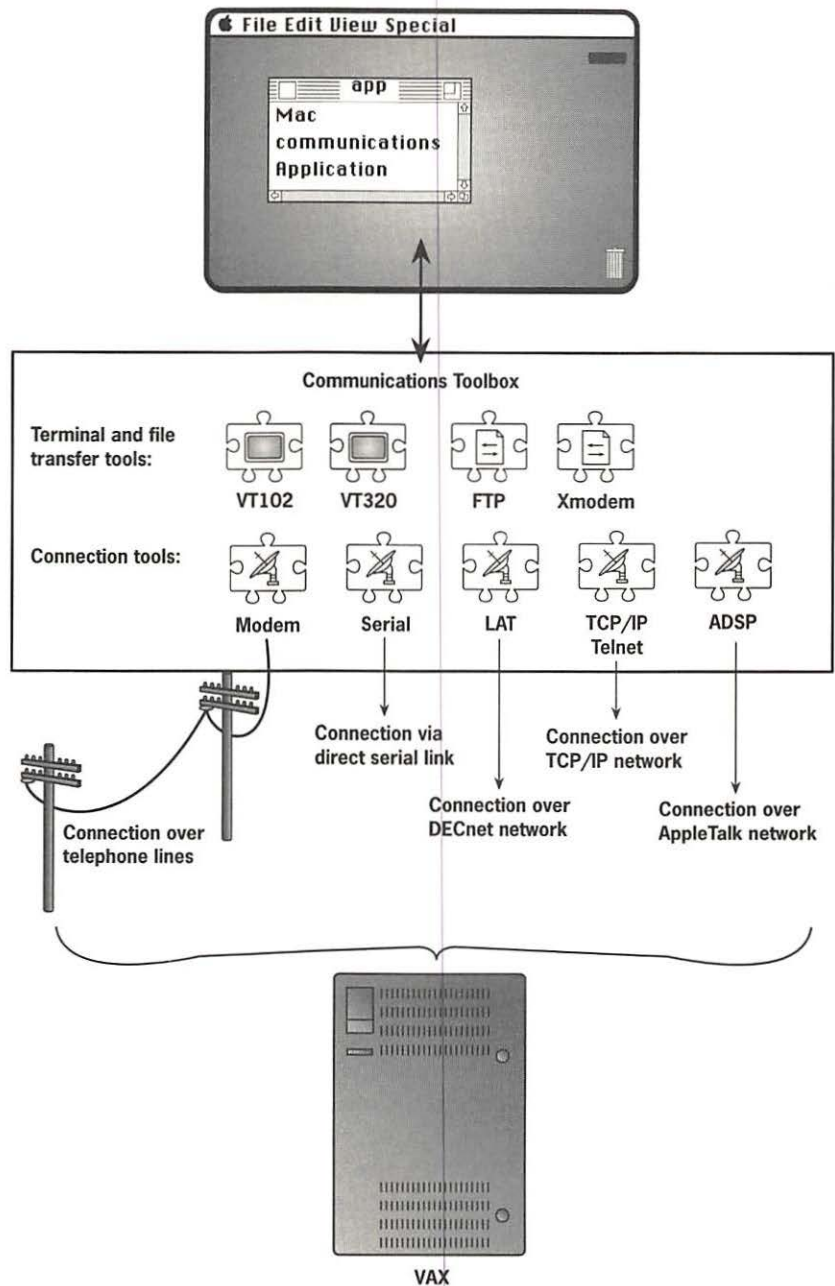
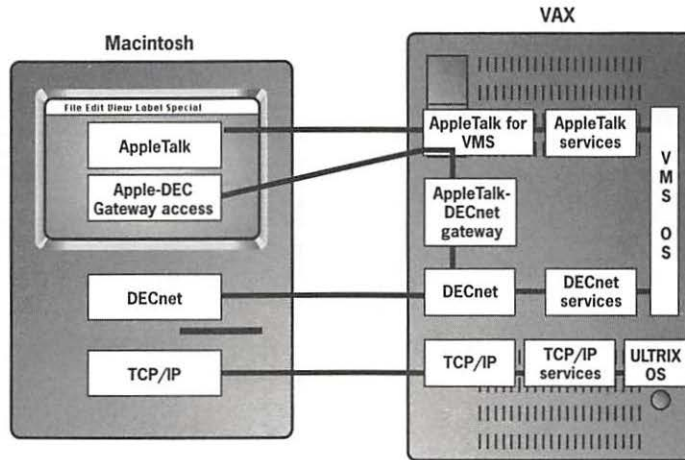

Figure 9.2

Network options for Mac-to-VAX connectivity include AppleTalk, DECnet, a DECnet gateway running on the VAX, and TCP/IP.



The DECnet Network

DECnet is modular in design, allowing computers running VMS, ULTRIX, Mac, DOS, OS/2, and other operating systems to communicate with each other over a network. Terminals can also be run over DECnet. The most recent version is DECnet Phase IV, which can accommodate 64,000 nodes on a single network. Data links that will work with DECnet include Ethernet or the industry standard X.25 wide-area communications protocol (which will be discussed in Chapter 13). In addition, DECnet protocols can run over a synchronous or asynchronous point-to-point serial link using Digital's proprietary Digital Data Communications Message protocol as the data link. Macs on LocalTalk networks can join a DECnet network with the use of a LocalTalk router that supports DECnet protocols, such as the Shiva Fastpath 5.

DECnet can also be used to communicate with computers on other networks via gateway software for the VAX provided by Digital. DECnet gateways are available to such networks as IBM's Systems Network Architecture (SNA) for access to mainframes, the Manufacturing Automation Protocol used in high-tech factories, as well as AppleTalk. DECnet also supports file, print, and database serving, electronic mail, and other network servers. Like TCP/IP, DECnet nodes are not self-configuring, as are AppleTalk nodes. Users will need to configure their Macs with information such as the DECnet area number and node number, as well as other parameters that usually can be obtained from a DECnet network manager.

The Mac can become a node on DECnet by the addition of software to the System Folder. One such system file is TSSnet from Thursby Software Systems, a product which has in the past been distributed by Pacer and White Pine. Digital also offers a product called DECnet for Macintosh, which includes a connection tool for the Communications Toolbox. DECnet for Macintosh allows you to directly access DECnet-based services, such as file transfer, wide-area network terminal communications, and electronic mail. As a DECnet node, your Mac can also access DECnet applications running on VMS, ULTRIX, OS/2, and DOS computers. The connection is direct, so you don't have to go through a VAX server first. A DECnet node can also directly access Digital's network management facilities. Another utility, DECnet File Access Listener, will back up Mac hard drives to the VAX.

AppleTalk for the VAX

Apple's AppleTalk for VMS is a software package for a VAX running the VMS operating system. AppleTalk for VMS not only enables the VAX to become a node on an AppleTalk internet, but adds functionality to an AppleTalk network. AppleTalk for VMS is usually licensed to developers, who include it in their VAX-based AppleTalk products. AppleTalk for VMS is the basis of the AppleTalk server products—described later in this chapter—which are generally the easiest way for an individual Mac user to take advantage of a VAX.

AppleTalk for VMS allows a VAX to act as an AppleTalk Phase 2 router. The router has multiple ports, and can route packets between several local area and wide-area networks that are connected to the VAX. The AppleTalk for VMS router also supports the AppleTalk-to-DECnet Transport Gateway, VAX software that can translate packets between AppleTalk and DECnet. Together, the router and gateway can provide AppleTalk tunneling through DECnet by encapsulating AppleTalk packets inside of DECnet packets, similar to the way in which AppleTalk is encapsulated inside of TCP/IP, as discussed in Chapter 6. The result is to connect two AppleTalk networks connected to a DECnet network without the users needing to have any knowledge of DECnet.

In addition to the application running on the VAX, the AppleTalk-to-DECnet Transport Gateway also comes with software for the Mac. A Chooser driver displays the Transport Gateway as a network service. However, Mac applications must incorporate routines that enable them to make connections to the Transport Gateway from AppleTalk. The Transport Gateway Access tool is a Communications Toolbox connection tool that enables applications that support the Toolbox to make use of the Transport Gateway.

■ VMS Application Access

You can take advantage of the processing power of the VAX by using a Mac as a front end to an application running on the minicomputer. The application you access may be one you use infrequently, or a production or enterprise application you need on a daily basis. In either case, you can use your Mac to access an application over a local or wide-area network.

Two ways to access VMS Applications are through terminal emulation and the X Window System. Terminal emulation is software running on your Mac that appears to the host to be a video display terminal. A terminal is basically a display monitor and a keyboard with very little processing power of its own. The X Window System assumes that the user's computer has some processing power of its own, and off-loads running the graphic interface portion of the application to the personal computer.

Both methods give you a Mac window displaying an application running on a VAX. The LAT protocol enables terminal emulation to occur over Ethernet, just as the X Window System is run over a network.

Choosing a Terminal Emulator

Terminal emulation is the simplest way to access a VAX application. You don't need any special software running on the VAX, just a terminal emulator on your Mac. Many of the terminal emulators available for the Mac use the Communications Toolbox, which requires you to add connection and terminal tools to your System Folder. The LAT tool is implemented by several files, including a Control Panel used to set parameters. Terminal emulators that don't use the Communications Toolbox often have built-in terminal and LAT functionality. Many terminal emulation products also support Telnet terminal emulation to UNIX hosts over TCP/IP. Regardless of whether the connection is over a network or serial link, terminal communications with a VAX are always asynchronous.

The VAX can be accessed by using several types of terminals that support text-only, black-and-white graphics, or color graphics (see Table 9.1). Which terminal you use depends on what the application running on the VAX requires or can support. The VT series contains the most widely used emulators, although terminals from other manufacturers can be used with a VAX. The basic Digital terminal functions can be found in the text-only VT100 or VT102 terminals. VT100 terminal emulation is found in most emulation packages for the Mac. Most VAX applications support VT100 terminals. The VT240, VT241, VT330, and VT340 terminals support graphics through Digital's ReGIS remote graphics language. The most advanced color terminal, the VT340, supports 16 colors. Digital's VT terminals are generally backwards compatible, supporting older terminals.

Table 9.1

Digital Equipment Corp.'s video display terminals can be emulated on a Mac.

TERMINAL	TEXT ONLY	BLACK-AND-WHITE GRAPHICS	COLOR GRAPHICS
100 Series	VT100, VT102	none	none
200 Series	VT220	VT240	VT241
300 Series	VT320	VT330	VT340

In addition to choosing which terminals you need, there are some features to look for in a terminal emulation software package. Although emulation over a modem line is limited to one terminal session, terminal emulators supporting LAT network connections can run multiple simultaneous sessions. Some emulators let you run multiple sessions through more than one type of connection. Sessions often are displayed in their own separate window. Each session window can be running a separate application or the same application on one or more hosts.

Running multiple terminal sessions allows you to copy and paste text and bitmapped graphics between them, or between sessions and Mac applications. A handy feature is the ability to do a copy in table format, that is, copy a rectangular area of the screen containing multiple partial lines, rather than entire lines as with a word processor (see Figure 9.3).

Some terminals use keys not found on Mac keyboards. One way terminal emulators handle this is to map a terminal keyboard onto your Mac keyboard. The feature, sometimes called keyboard mapping, can be implemented in several ways. The basic method is to provide the user with a selection of one or more preset standard terminal keyboard mappings that can be set through a dialog box. You can sometimes modify keyboard mapping on a character-by-character basis, enabling you to assign frequently used terminal function keys to a convenient spot on your Mac keyboard.

Another useful capability is file transfer. Some emulators provide file transfer protocols found in general purpose telecommunications packages discussed in Chapter 3, such as Xmodem, Ymodem, and Kermit. Terminal emulators that work over TCP/IP often supply UNIX FTP file transfer as well.

A Review of Terminal Emulation Products

Mac users who need to access a VAX have a wide variety of products from which to choose, starting at the low end with modest costs, moving up through increasing complexity and features. Descriptions of some of the more popular packages follow.

Figure 9.3

Handy terminal emulation features include the ability to copy as a table, as shown here with Synergy's VersaTerm-PRO, and the ability to run multiple sessions, handled here with a palette. Other emulators use multiple windows.

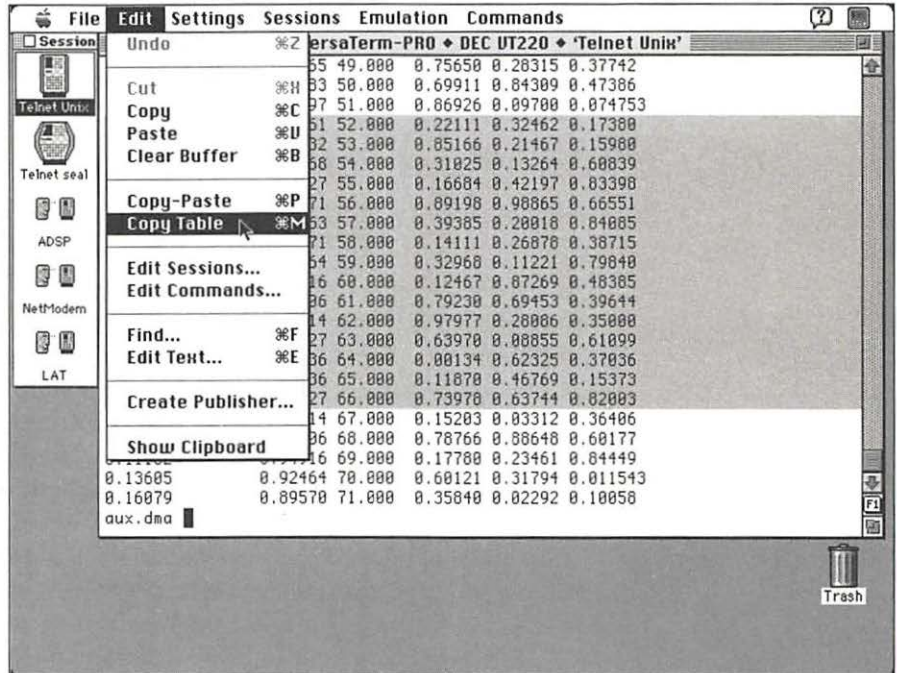

Apple's MacTerminal is basic, and like many of the terminal-emulation products available for the Mac, it is based on the Communications Toolbox. MacTerminal is a simple, inexpensive package that gives you VT320 and VT102 terminal emulation, as well as Xmodem file transfer.

VersaTerm-PRO from Synergy Software is used for terminal sessions over a modem or a DECnet network using the Communications Toolbox LAT tool, as well as for Telnet sessions over TCP/IP and SLIP serial connections. You can even run these sessions at the same time through different ports on your Mac. VersaTerm-PRO supports VT 100 and 220 and text terminals, as well as the Data General D200 and Tektronix 4010 series text and graphics terminals used in many science and engineering applications. Panning and zooming on graphics screens is supported in Tektronix modes. VersaTerm-PRO allows you to cut or copy sections of the terminal graphics and paste them into Macintosh documents and to save terminal screens as PICT or bitmapped paint files. VersaTerm-PRO supports eight simultaneous sessions, but displays only one window. You can switch between sessions using the Session Palette (shown in Figure 9.3), a feature designed to make multiple sessions manageable on 9- and 13-inch monitors.

White Pine Software's Mac320, Mac330, and Mac340, Communication Toolbox-compatible terminal emulator products, are the latest in a long line of Mac-to-VAX terminal products from this company (see Figure 9.4). All three products provide color text and background, even on the black-and-white VT330 graphics terminal emulator. Mac330 and Mac 340 also emulate Tektronics 4010 and 4014 terminals. Although Digital's VT 300 series terminals allow you to connect to two hosts with two sessions, the Mac300 series emulators allow you to open as many sessions to as many hosts as your Mac has memory for. You can also open a session to Digital's PathWorks using an ADSP connection over AppleTalk. Other connections direct serial, modem, LAT, and Telnet. File transfer is provided through FTP, Xmodem, and Ymodem protocols.

Figure 9.4

White Pine's Mac340 provides Digital VT340 terminal graphics through a variety of connections.

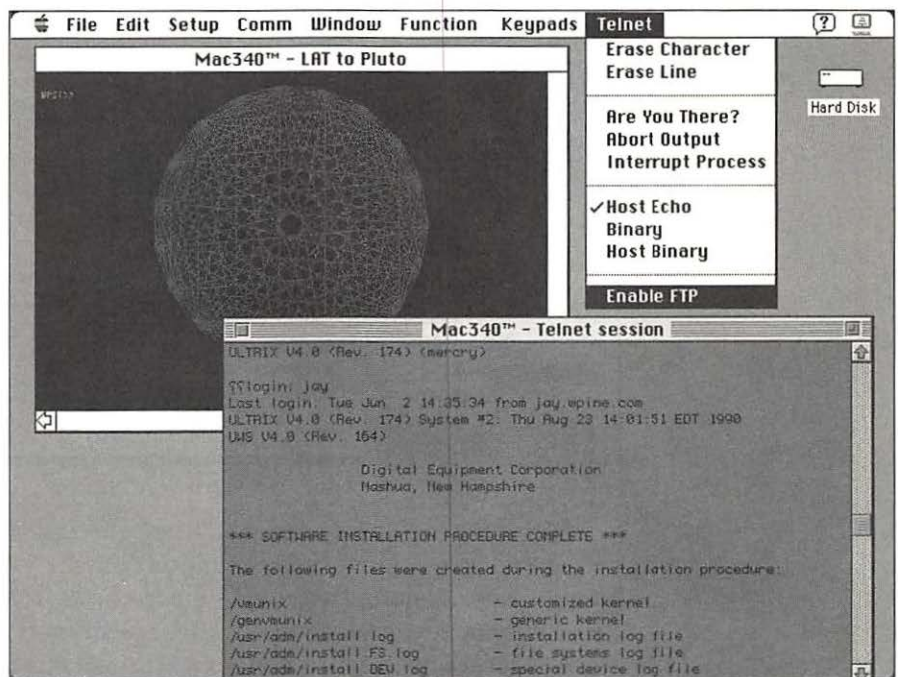

Pacer has two different terminal emulation products, PacerTerm and PacerLink, as well as a VAX product, PacerConnect, which can aid any communications Toolbox terminal emulator. PacerTerm is the lower-end product, totally based on the Communications Toolbox (see Figure 9.5). File transfer tools include TCP/IP FTP, Kermit, Xmodem and Zmodem, as well as Pacer's own PacerFT file transfer protocol. PacerTerm also comes with

scripting abilities via HyperTalk, the high-level programming language from Apple's HyperCard. Using HyperTalk, you can automate repetitive tasks and customize your own Mac interface to a VAX application. You could, for instance, create a dialog box front end to replace the command line options of VAX terminals. PacerTerm also features key-mapping capabilities and a window called SoftKeys, which contains 20 on-screen user-definable buttons to perform terminal functions or HyperTalk scripts.

Figure 9.5

PacerTerm enables users to create front ends for terminal sessions using HyperTalk.

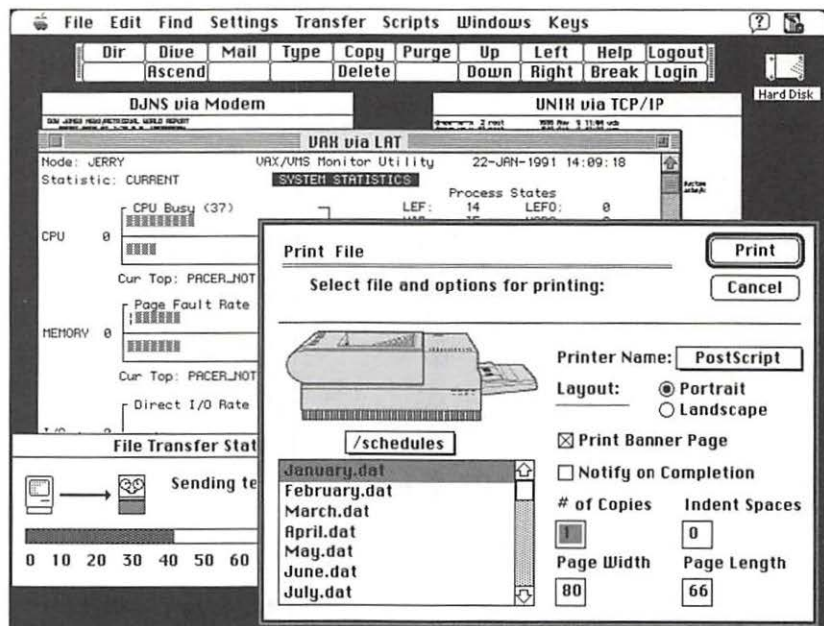

PacerLink is a high-end terminal emulation and communications package with software components; it runs on both the VAX and the Mac. In addition to VAX hosts, PacerLink supports hosts from Data General, Stratus, and Prime, as well as several UNIX hosts. PacerLink can integrate a network of various hosts into a uniform environment, and supports both Macs and PCs as clients.

PacerLink's terminal emulations include Digital VT100 and VT220, as well as Data General D461, Prime PT200 and PT250, and Stratus V102 for access to other hosts. An optional module, PacerGraph, adds VT240 and VT241 graphics capabilities. PacerLink also comes with some of the interface features of PacerTerm, such as key mapping and programmable SoftKeys.

PacerLink also offers file transfer and print services for both Macs and PCs, allowing the two to share files and printers. Mac users can select VAX printers from the Chooser. Another feature is virtual disk service, which allows you to use a portion of the host hard disk for your own data. A virtual disk appears on the Mac desktop as an ordinary hard disk. Virtual disks can be backed up automatically by the normal VMS processes.

Most terminal emulation products cost a few hundred dollars for software on the Mac, but because PacerLink also has software for the host, its cost can run from several thousand to thirty thousand dollars, more in line with the file server products discussed later in this chapter.

PacerConnect is an ADSP server that runs on the VAX. It supports ADSP terminal connections—which are more efficient than LAT connections—over AppleTalk from Mac to VAX. With PacerConnect on the VAX and the PacerTerm terminal emulation software on the Mac, users can get some of the speed benefits of the high-end PacerLink, but at a lower price. With PacerConnect on the VAX, users can also use non-Pacer terminal emulators that can use the Communications Toolbox ADSP tool, such as Apple's MacTerminal.

DECwindows

The X Window System on a VAX is called DECwindows, which works much the same as it does under UNIX (see Chapter 8). The VAX does the processing while the Mac runs the user interface.

However, between terminal emulation and X Window, there is a big difference over who is in the driver's seat. Applications accessed through terminal emulation are completely host-driven—the VAX prompts you for responses, which you must answer before going on to the next step. X Window applications give users more control over a program than does terminal emulation. Instead of the exam you often face with terminal emulators (*enter the correct response or go no further*), X allows you to choose items from menus or enter settings in dialog boxes at your own initiative. An X Window user environment is also a more friendly, intuitive one than a terminal emulator. X Window applications are often seen as a halfway point between host-terminal and client-server computing.

Although there are VT terminals that can display graphic images, their interfaces are still command-driven. DECwindows applications offer true graphics interfaces with menus, dialog boxes, buttons, and windows with scroll bars. The exact interface depends on the X Window software running on the Mac. DECwindows applications don't have to be specifically written for the Mac, but can be accessed by any computer running industry-compliant X Window software.

DECwindows applications can be accessed by users with Apple's MacX or White Pine's eXodus software for the Mac (both are described in Chapter 8).

Those wishing to develop DECwindows applications can obtain Digital's DECwindows Toolkit, which provides programming tools for both VMS and ULTRIX.

■ The VAX as a Mac File and Print Server

Accessing a VAX in the traditional host-terminal mode is useful, but is not the most efficient way to make use of a VAX. Since Macs and PCs are capable of much more than acting as dumb terminals, a VAX being accessed by a large number of desktop computers for terminal emulation only can be considered a waste of collective processing power. It is more efficient to distribute the processing power by using the client-server model (as described in Chapter 7). By putting the applications on the clients and reducing the role of the VAX to that of server of information—files, databases, and electronic mail—the load on the VAX is lessened and bottlenecks are reduced. In addition, running the applications on desktop computers instead of on hosts allows users to access resources in a manner that is familiar to them.

There are several software solutions available for the VAX running VMS that provide file, print, and mail services, as well as database access and corporate-wide functions, such as distributed transaction processing, all in a very Mac-like manner. For Macs, there are three major sets of products: Digital's own PathWorks, AlisaTalk for VMS from Alisa Systems, and PacerShare from Pacer Software. All three of these VAX server packages are based on AppleTalk for VMS and offer AFP-compatible file service, so that a VAX volume is selected from the Chooser and mounted on the desktop, as with any AFP server volume. VMS directories appear as AFP folders within the mounted volume.

Digital's PathWorks is a multivendor, multinetwork scheme that allows Macs and PCs of any operating system to share the same data. In large corporate sites, PathWorks is a competitor to PC-server-based network operating systems such as Novell NetWare, but can harness the power of the minicomputer as a server.

PathWorks for Macintosh provides the necessary VAX server software, as well as a collection of Mac software from Digital and Apple. Part of the PathWorks for Macintosh package, called VAXshare, is based on AlisaShare file sharing technology licensed from Alisa by Digital. PacerShare is a completely independent product.

PathWorks

PathWorks is the most complete VAX networking environment, fitting into Digital's Network Application Support (NAS) network architecture, a complete client/server-based description of services, database applications,

and developer tools in a mixed environment (see Figure 9.6). PathWorks clients can be Mac, DOS, Windows, OS/2, and UNIX, and servers can be VAX minicomputers running VMS, or smaller workstations from Digital or other vendors running ULTRIX or OS/2.

Figure 9.6

Digital's PathWorks provides a complete VAX-based network solution for a variety of servers, clients, and hosts, including Macs.

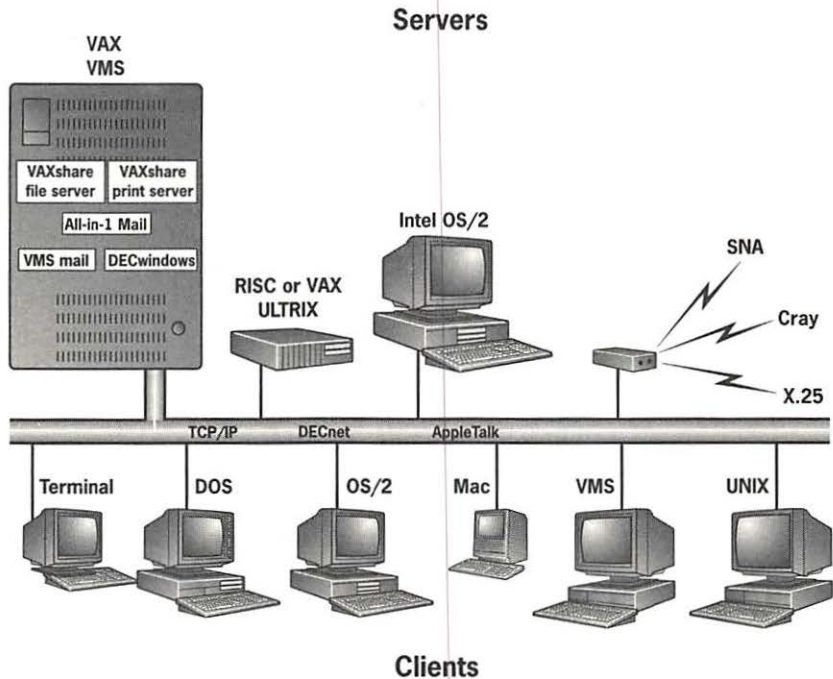

A benefit of PathWorks for Macintosh is that it comes with most of the Apple and Digital Mac-to-VAX software that you'll ever need. This includes DECnet for Macintosh, MacTerminal, MacX, AppleTalk for VMS, the AppleTalk-to-DECnet Transport Gateway, VAXshare AFP file service, print service, database access (via Apple's Data Access Language), electronic mail, and an AppleTalk router. PathWorks also comes with a set of Communications Toolbox software, including the LAT and CTerm tools, and a gateway-access connection tool. A single installer program can install all of the Mac software at one session. The Mac software installation is not as easy as a Macintosh System install, but it is convenient to have all of this Mac-to-VAX connectivity software in one place.

VAXshare is the portion of Digital's PathWorks that implements an AFP file server on the VAX. To enable PCs to share the same data as Macs, you must also run a software package called PathWorks for VMS on the

VAX. From a Mac user's perspective, a VAXshare volume behaves in every way as an AppleShare volume.

In addition to being able to store files and folders on a desktop-mountable server volume, Mac users can also access VMS directories and files that were created by VMS users or applications. VMS users can access Mac files because a Mac file's data fork is represented on the VAX as a VMS stream file. Mac files with resource forks (such as Mac applications) have a second VMS file associated with them.

When sharing files with VMS users, it may be convenient to use a pair of file formats that Apple and Digital support as common interchange formats. DDIF, the Digital Document Interchange Format, is used for text and graphics, and DTIF, the Digital Table Interchange Format, is used for data tables and spreadsheet formulas. Converters that run on the VAX to translate DDIF, DTIF, and Mac formats are available from Apple and Digital. Translators are also available for XTND-compatible Mac applications.

VAXshare also implements the AppleTalk's PAP printer-sharing protocol. VAXshare provides print spooling for AppleTalk printers and also gives Macs access to Digital's high-speed PostScript laser printers attached to one or more VAXes on the network. Print spooling for both AppleTalk and VAX printers occurs on the VAX computer. VAX printers appear in the Chooser just as AppleTalk printers normally do. VAXshare also gives access to AppleTalk printers to any DOS or OS/2 clients on the network.

The performance you get from PathWorks and VAXshare depends on the type of server you are running, but the best performance will be on the bigger VAX minicomputers.

PathWorks offers significantly more data security than does AppleShare. In addition to automatic backup of data stored on the file server, you can set the VAX to automatically back up Mac hard disks over the network through the DECnet File Access Listener utility. Through a VMS feature called VMS access control lists, VAXshare allows the VMS system manager to control access to a particular file or folder. This is in addition to the standard AFP security features.

In-house developers can write Mac software that accesses VMS database servers based on SQL (structured query language). Macs can use either Apple's Data Access Language (DAL) or Digital's NAS database service (database connectivity is the subject of Chapter 11).

A third-party program, NAServer Administrator from Webster Computer Corporation, puts PathWorks administration on a Mac with a Mac-like interface. The Administrator consists of software for a VAX server and a Mac client connected via DECnet. Administrator provides extensive administration for file and print services, for server disk and backup control, as well as for users, including both Mac and PC clients. Because text commands are

turned into menu commands and dialog box choices, NAServer allows someone who may have Mac experience, but little VMS training, to act as a PathWorks administrator.

Alisa and Pacer

VAX servers for VAX from Alisa and Pacer are basically Mac-only solutions, but can also serve PCs with AppleTalk and AFP software, as discussed in Chapter 2. In addition, running Alisa or Pacer file server software on a VAX doesn't preclude adding software to the VAX host for other types of clients.

AlisaTalk for VMS consists of the AlisaShare file server and the AlisaPrint print server, both of which are licensed by Digital for inclusion in PathWorks for Macintosh. As such, AlisaShare has all the features of Digital's VAXshare. AlisaTalk for VMS and PathWorks for Macintosh cost about the same, but Digital charges more for upgrades.

Like VAXshare and AlisaShare, PacerShare installs an AFP file server on the VAX. PacerShare distinguishes itself by running on other hosts as well, including VMS and UNIX hosts from Data General and Motorola. PacerShare host software also runs on the HP 9000 minicomputer and the Sun SPARCstation. Extension mapping of foreign files (see Chapter 2) is provided, so that foreign files will open in a predetermined Mac application. PacerShare also provides a mapping of Chooser names to VMS server names. In testing by various publications, PacerShare has been shown to provide good performance as an AFP server on a VAX. PacerPrint is VAX software that gives Mac users access to VAX printers, and non-Mac users access to AppleTalk PostScript printers. PacerPrint will convert non-PostScript ASCII print jobs to PostScript.

■ VAX Electronic Mail Servers

A mail server running on a VAX can handle many more mail transactions and more users than can a server on a Mac. You also get the automatic backup and security of a VAX. Several types of electronic mail service can be run on a VAX, and there are various types of solutions that can integrate Macintosh and VAX. The Macs can participate directly as VAX mail clients, or gateways can be set up between VAX and AppleTalk mail services. There are also ways to use the VAX as a mail server for Macintosh mail programs.

The most basic mail service on the VAX is VMSmail, a mail utility that is part of the VMS operating system. It enables users to send, receive, reply, and forward messages, but lacks the advanced message-handling features of most Mac mail applications. A Mac application that uses the Communications Toolbox can access the VMS Mail server.

Digital's All-in-1 Mail is a feature-rich electronic mail system that is available as an optional mail server for the VAX. All-in-1 Mail is a store-and-forward system that is compliant with the CCITT X.400 specification, which was designed to deliver e-mail over local or wide-area networks. All-in-1 Mail features include mail message notifications, as is common with Mac mail programs. Information about the message, such as priority and expiration date, is also sent with a message. Messages can be filed on the server or locally on the client. All-in-1 Mail also makes use of Digital's Distributed Directory Services (DDS) for addressing other users on a VAX MAILbus electronic mail network. All-in-1 Mail features can be integrated into applications (just as Microsoft has integrated Microsoft Mail into Excel and Word), so that users can send a copy of an open file without leaving the application.

PathWorks Mail Features

PathWorks provides Mac client software for VMSmail and All-in-1 Mail. (All-in-1 Mail server software is not included with PathWorks.) These services are implemented as Basic Mail for Macintosh and All-in-1 Mail for Macintosh. Basic Mail for Macintosh is VMSmail with a Mac interface. With it, users can send and receive messages from users running Macs or other computers on the VAX server. With the addition of Digital's MAILbus products, users of Basic Mail and All-in-1 Mail can trade messages through other servers on the network, as well as through other X.400 servers.

All-in-1 Mail for Macintosh provides users with a graphical interface that uses a file cabinet metaphor to enable users to create, edit, and manage mail messages. A user can arrange messages in drawers of the file cabinet or within folders in the drawers. A personal address book is supplied for storing names, mail addresses, and telephone phone numbers of other users. Users of both Basic Mail for Macintosh and All-in-1 Mail can exchange e-mail with other mainframe mail systems, such as IBM's PROFS and DISOSS systems, as well as private X.400 servers. This includes Apple's X.400 server, MacX.400, which will be discussed in Chapter 13.

Macs must access the All-in-1 Mail server through DECnet. This can be through the use of the AppleTalk-to-DECnet gateway or by using the Mac as a DECnet node with DECnet for Macintosh or TSSnet.

Third-Party Mail and Messaging

The major company for mail packages for Mac and VAX is Alisa Systems, which has been making these types of products for almost as long as there have been Macs. Alisa offers two classes of products—inexpensive Mac-based products, such as mail gateways, and a full-featured integrated VAX-based mail server.

Gateways and Conferencing

As with other types of gateways, gateways to VAX mail systems are economical but slow solutions. Alisa's MailMate gateways run on a Mac and translate between Mac-based electronic mail systems and VMSmail or All-in-1 Mail or other X.400 mail services on the VAX. There are versions for either Microsoft Mail and CE's QuickMail; both are identical in features and functions. However, you can run into problems if you connect the VAX to too many networks that have different mail systems. With a different gateway for each mail system, performance could really suffer.

Alisa's MaxNotes is a Mac front end for Digital's VAX Notes electronic conferencing system. An electronic conference—similar to the conferencing features found in some of the on-line services, such as America Online and CompuServe—is an online session in which multiple users on the network can participate in a conversation. Users in MaxNotes can open multiple windows at once, browsing and participating in several different conferences and cutting and pasting between them. MaxNotes sessions can be held over either an AppleTalk or a DECnet connection.

AlisaMail

In addition to its MailMate gateway products, Alisa has a mail integration package, AlisaMail, which runs on a VAX. AlisaMail is not a gateway, but a complete store-and-forward mail server. AlisaMail can serve mail to a variety of clients using native client software. AlisaMail contains integration servers that act as translators speaking the native mail languages of a variety of VMS, Mac, and PC mail systems. The AlisaMail server can also connect to VMSmail and All-in-1. In fact, AlisaMail brings a store-and-forward architecture to VMSmail, which is not store-and-forward in its normal configuration.

On the Mac, AlisaMail supports Microsoft Mail and QuickMail clients (see Figure 9.7). Nothing needs to be added to the Macs except the standard client software from Microsoft or CE Software. On the PC, AlisaMail supports PC Mail, the PC version of cc:Mail, Microsoft Mail PC, and any mail system compatible with the Novell's message handling service (MHS), such as Da Vinci Mail. Users of all of these client systems can communicate with each other through the AlisaMail server running on the VAX without any knowledge of what client software they are running.

At the center of AlisaMail is a relational database called the Information Switch, which stores messages and provides forms for management. The database contains information on which file formats (such as Lotus 1-2-3 or MacWrite) are preferred by each client, and will automatically translate into the preferred format documents attached to a message addressed to a client. The Information Switch also contains directories of the various e-mail systems in use. The organization of multiple directories and resolution of

conflicts is called *directory synchronization*, which gives you an entire list of everyone in the company using e-mail.

Figure 9.7

AlisaMail integrates a number of electronic mail systems running on Macs, VAXes, PCs, and UNIX machines.

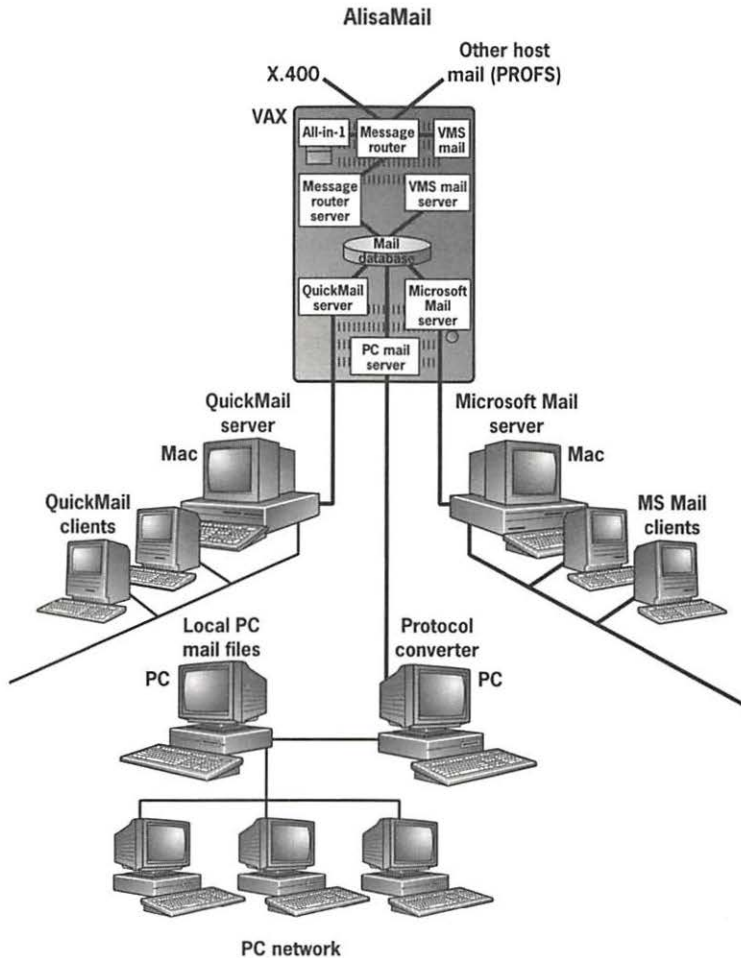

An optional People Finder utility can find anyone on a corporate internet. The People Finder is a directory of directories, allowing you to do searches by organization and location. When you click on a name, you get a profile of a person with name, address, a notes field, a photograph, and other data. When you send messages to people, you don't have to remember what type of computer or mail system they use, or their address.

If some of this sounds familiar—such as Digital’s personal address book that comes with PathWorks or Banyan VINES’s StreetTalk directory service—it’s no accident. Integrated internet-wide directory services are a major multi-platform connectivity trend for the nineties. I’ll discuss what universal directory service Apple has up its sleeve in Chapter 14.

■ Looking Ahead

In this chapter, we looked at Mac connections to Digital VAXes: network links, host-terminal access, and client-server file and mail services. But this is by no means the whole picture. There is one major Mac-to-host connectivity area that I haven’t yet addressed—databases. This is one of the most crucial areas for company-wide information systems, otherwise known as enterprise computing. However, VAXes aren’t the only hosts used to store databases that Macs can access. So, before we get to the chapter on database connectivity, there is one more important area of big computing that concerns the Macs: IBM mainframes, the subject of the next chapter.

The alliances between the big three forces—Apple, Microsoft, and IBM—almost Orwellian in nature, shift every few years to produce a different enemy. Once, Macs were as common in IBM mainframe environments as a cathode ray tube on a circuit board. But now that Apple and IBM are partners, connectivity solutions between the two worlds abound, and the IBM booths at big networking trade shows are crawling with Macs. Still, to the Mac user, the realm of VAX connectivity is friendly and familiar, compared with the alien world of IBM mainframes.

- *The Physical Connection*
 - *3270 Terminal Emulation Software*
 - *Front-Ending Host Software*
 - *Client-Server Computing in the Mainframe Environment*
 - *Accessing the Midrange*
-

CHAPTER

10

Mainframe Connections

SINCE 1956, IBM HAS HAD THE DISTINCTION OF BEING THE world's biggest computer company, the General Motors of the computer industry. Stock markets can rise and fall according to IBM's fortunes. There are other mainframe manufacturers, but they don't have IBM's widespread presence in management information systems (MIS) and data processing centers in business, government, and education. In addition, no other mainframe has as many connections to personal computers as IBM has. So, when at the end of 1991, IBM officialdom blessed the Macintosh by acknowledging it as a proper way to access a mainframe, users and MIS directors breathed a sigh of relief. You see, the number of

Macs among the white shirts and skyscrapers of corporate computing had been growing steadily, though somewhat furtively, each year. With the benediction of Big Blue, Macs could now be purchased openly and integrated into the corporate-wide enterprise information systems of more companies. Today, the Mac can fit into the mainframe environment anywhere a PC can.

IBM was already a successful provider of mechanical tabulation machines for business when computers were invented in the late 1940s. It was IBM that first put the computer, a tool mostly for scientists and researchers, into the hands of business on a wide scale. The IBM 650, introduced in 1953, was the first mass-produced computer. It wasn't the fastest computer of its time, but IBM put its well-established army of sales personnel to work to convert its data processing customers from adding machines to computers. This was the same marketing muscle that made the IBM PC the standard personal computer almost 30 years later. In the 1960s, System/360 began the family of modern mainframes that stretches to today's System/370 (S/370 for short) and S/390, each of which comprises a line of mainframes. These big machines usually run the MVS/ESA operating system. IBM also offers smaller mainframes, such as the ES/9000, which runs the VM operating system, as well as some midrange systems such as the AS/400, which runs the OS/400 operating system.

Macs today are connecting to all of these systems, but the techniques and concepts are more foreign to Mac users than are other types of computer systems. Although it's not quite quantum thermodynamics, mainframe systems and their connectivity schemes are complex, with a vocabulary filled with strange terms, acronyms, and numbers. With PCs, UNIX machines, and VAXes, the Mac user could see connectivity as an extension of the Mac networking environment—more AppleShare servers accessible by a standard network. Not so with the mainframe environment.

Connectivity in an IBM mainframe environment is governed by IBM's Systems Network Architecture (SNA), a suite of protocols and routing algorithms originally designed around a host-terminal model of computing, which is still the most common method of accessing a mainframe today. At the center is the mainframe, running the applications. User access to mainframe applications and services is through 3270 (or 327X) devices, a family of terminals, printers, and related connectivity hardware. Within SNA, 3278 and 3279 terminals are used to access a variety of IBM mainframes and host operating systems.

During the 1980s, intelligent personal computers gradually began replacing dumb terminals; 1991 was the first time that sales of IBM terminals actually declined. Because of this, IBM broadened SNA to include personal computers and local area networks.

Macs have become more active in SNA, particularly since the set of cooperative agreements between Apple and IBM were signed in 1991. Both

companies have committed to making the other's computers a native part of each other's overall computing strategy. Thus, Macs fit into SNA, as well as into IBM's System Application Architecture (SAA), a design for shared enterprise applications running on many of IBM's mainframe products. In addition, IBM mainframes are part of VITAL, Apple's enterprise-wide information system strategy. VITAL will be discussed in the next chapter, but first, let's make a connection.

■ The Physical Connection

Traditionally, IBM mainframe connections to terminals have not been made through local area networks. SNA's first LAN option wasn't until 1985, with the introduction of IBM's first token ring products. Most terminals were connected to the mainframe in a very hierarchical setup, much like a corporate organization chart: the mainframe at the top, like a CEO and the terminals at the bottom. In between were several layers of equipment used to distribute signals. Today, there are three basic methods to connect a Mac to the IBM mainframe environment: through a coaxial terminal adapter card, a synchronous data link control (SDLC) connection, or a token ring network. Which method you choose depends on what mainframe connectivity hardware and software you have at hand, as well as the number of users that plan to connect.

Each of these three connection methods can link a Mac directly to the mainframe system, or through a gateway to SNA. Like token rings, coaxial and SDLC gateways connect a network of Macs or PCs to a mainframe. A token ring network can be connected to the mainframe via a gateway, or directly; Macs can be on the token ring network, or on other networks linked to the token ring with routers, gateways, or other connection methods. Certain mainframe systems now support Ethernet as well.

Direct coax and SDLC connections to individual computers tend to be more reliable than a gateway to a LAN, as they are sheltered from any problems a network might have. Not that LANs are unreliable, but they are subject to slowdowns caused by heavy traffic and other factors out of the user's control. Direct connections also tend to be faster than links through gateways. However, individual mainframe connections are cost effective only for sites that need to connect small numbers of Macs. SNA gateways to Mac networks, on the other hand, are cost effective for sites with dozens or hundreds of connected Mac users. Mainframe connection products for the Mac usually have the word *workstation* or *gateway* in the product name to differentiate between the individual (direct) and gateway (network) versions of the product.

There are three major sources of hardware and software for making the Mac-to-mainframe link: Apple, Avatar, and Digital Communications Associates (DCA). Avatar was the first to offer Mac-to-mainframe connectivity

solutions with the introduction of its MacMainFrame line of products in 1984, and it now supports PCs as well. A merger with Tri-Data in 1991 expanded Avatar's product line into token ring and high-speed SNA gateways. DCA was a pioneer in PC-to-mainframe communications, and over the years has brought many of its IRMA products to the Mac. DCA offers solutions in just about every area of Mac and PC connectivity with mainframes.

Coaxial Terminal Adapter Cards

The coaxial adapter card inside a Mac converts protocols from the mainframe to a language your Mac can understand. A coax card uses a coaxial cable to connect a Mac or PC to an IBM 3174 or 3274 cluster controller, a piece of hardware used to control the input and output of a group of terminals, personal computers, and printers (see Figure 10.1). One or more cluster controllers are connected to a front-end processor, a communications controller that connects groups of cluster controllers to the mainframe. The cluster controllers can be connected by a cable directly to the mainframe at the site, or scattered over long distances and connected to the front-end processor over an SDLC link over telephone lines.

A coax connection with a cluster controller is a reliable mainframe connectivity method with good performance. Coax cards are also the most expensive method of connecting a Mac, and make economic sense only for small numbers of Macs. Because 3270 terminals were meant to run continuously, you need to dedicate a port on the cluster controller for each personal computer, even when the Mac is turned off or is not running a terminal emulation session. This means that if you run out of cluster controller ports, you'll either have to buy another cluster controller (not cheap) or find another connection method.

A coax card solution is an easy way for a Mac to fit into a situation where cluster controllers and terminals already exist. To replace a terminal with a Mac with a coax card, you simply unplug the cable from the terminal and plug it into the coax card in the Mac. Dedicating a cluster controller port for a Mac coax connection is not difficult, and you don't need to add anything to the host.

Coax cards for various Macs are available from Apple, Asanté, Avatar, and DCA. Unlike PCs, which require modification of configuration files, the Mac recognizes a coax board when it boots up. Installing the card in the Mac is as easy as adding an Ethernet card, with no DIP switches to set. Keep in mind, however, that a coax connection to the SNA environment is not a local area network connection, since you can access only the host, and not any of the other PCs directly. (IBM has been extending SNA to enable clients to communicate with each other, but more on that later.)

Figure 10.1

Coaxial connections to a mainframe can be made directly to a cluster controller or through a gateway to a LAN. Cluster controllers connect to a front-end processor directly or through an SDLC link.

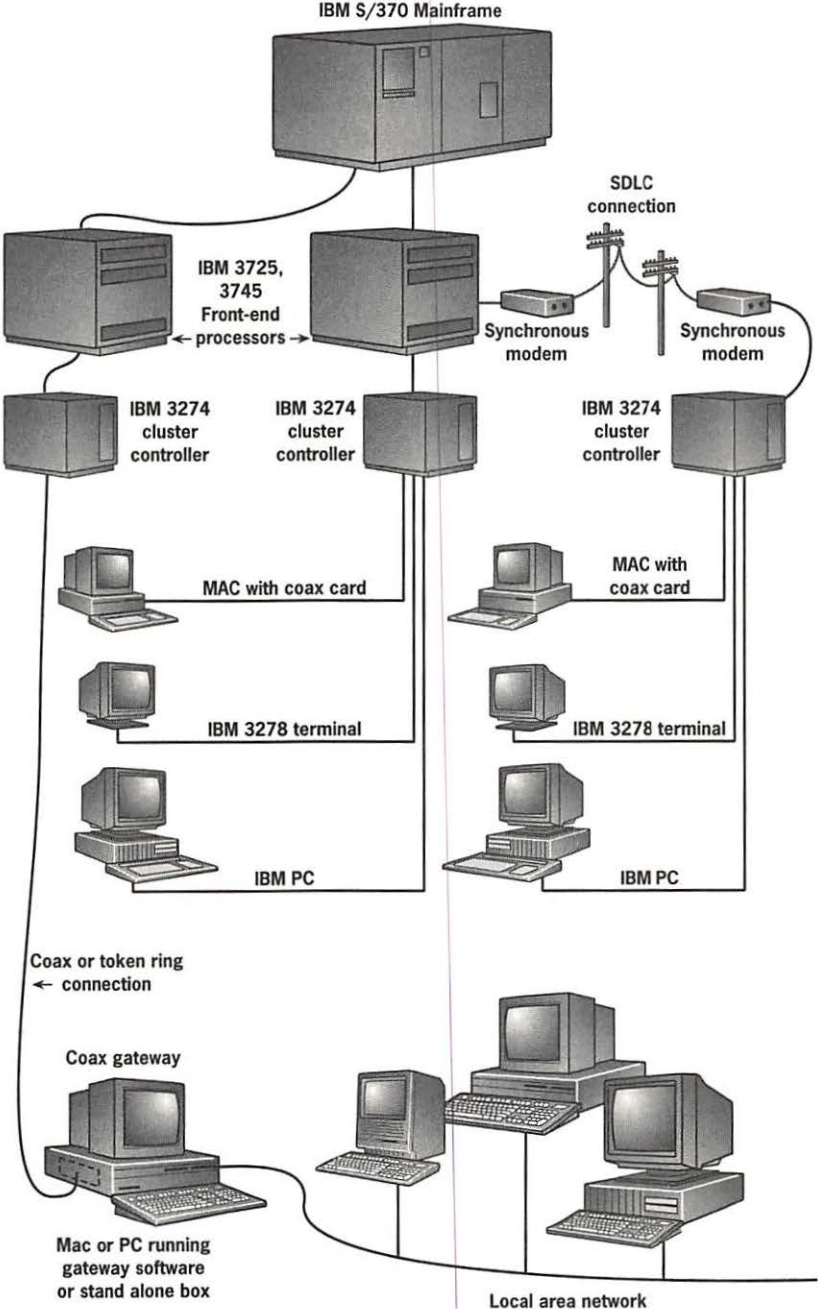

Avatar and DCA each offer coax cards and software that turn the Mac into an SNA gateway. Each gateway coaxial card can support five simultaneous sessions split up among five users. For more users, SDLC and token ring gateways should be used.

Synchronous Data Link Control (SDLC)

SDLC is SNA's original data link protocol. SDLC connections bypass the cluster controller, using synchronous modems to connect a Mac SDLC adapter card or external box to the mainframe front-end processor (see Figure 10.2). By comparison, the modems typically used at your desktop are asynchronous modems. The difference is that synchronous modems send and receive data in a timed manner; asynchronous connections don't time the interval between signals.

SDLC connections for individual Macs are not the fastest solution, since typical transmission rates are 19.2 kilobits (Kbits) per second between Mac and mainframe. SDLC cards for individual Macs are made by Avatar and Apple. Apple's Serial NB card is for NuBus-equipped Macs only; Avatar has SDLC solutions for every Mac.

An SDLC gateway for a network can be an add-in card for the Mac or an external box. SDLC gateways are the most cost-effective method for connecting large numbers of users, supporting up to 128 simultaneous users per gateway. An SDLC gateway can usually access the mainframe at 56 Kbits per second. Several SDLC gateways that run on a Macintosh are available. Avatar's MacMainFrame SDLC Gateway is an SDLC card and software that can run on most Mac models. Apple's serial NB card for Macs with a NuBus slot will act as an SDLC gateway with Apple's SNA•ps Gateway software.

Asynchronous Connections

SDLC is a synchronous serial connection. In some cases, you may want an asynchronous connection to connect an individual Mac remotely using an ordinary modem. This is possible if the mainframe has a piece of hardware called a protocol converter, such as an IBM 7171, to translate ASCII characters used on the Mac and the EBCDIC characters used by the mainframe. Mac asynchronous serial connections can be made directly over a serial cable or remotely with a normal desktop asynchronous modem, such as a Hayes-compatible model. Asynchronous terminal emulation software, such as VersaTerm-PRO, can be used in this case. Simware can provide asynchronous terminal emulation through its software protocol converter SIM3278 that runs on the mainframe; and SimMac, a 3270 terminal emulator that runs on a Mac. An advantage of the SIM3278 software protocol converter is that it can support a virtually unlimited number of users; a hardware protocol converter is

usually limited to a dozen or so users. A software protocol converter can also be more cost effective for dozens or hundreds of remote users.

Figure 10.2

A typical SDLC link uses synchronous modems to connect the Mac adapter card to a mainframe's front-end processor, bypassing the cluster controller.

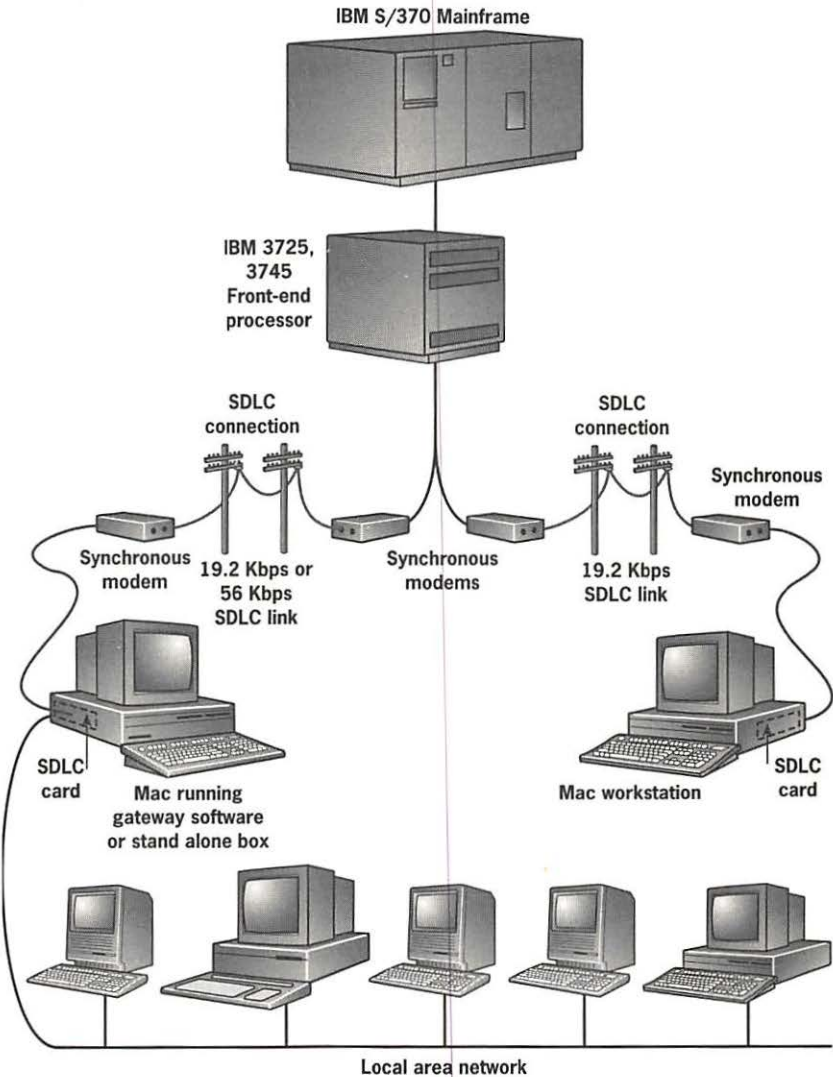

Token Ring Network

Token ring is IBM's official local area network of choice, although the popularity of Ethernet has forced IBM to adopt it as well. However, token ring is still more widely used in IBM mainframe environments, and only a minority

of Mac-to-mainframe connectivity products support Ethernet. Token ring networks can be connected directly to a mainframe or through a gateway. A gateway is likely to be cheaper, but a direct connection is faster. Direct connections to the host can be made through either a cluster controller or a front-end processor. Token ring cards for the Mac are provided by the three major Mac-to-mainframe companies—the Apple TokenTalk NB, Avatar LanWay, and DCA's MacIRMAtrac card—as well as by general-purpose connectivity companies. The mainframe connectivity companies often design their emulation software to work specifically with their own token ring cards, so buying a card from a general purpose connectivity company could hamper performance.

Multi-Access Network Gateways

Multi-access gateways to SNA take the place of the cluster controller and have the ability to connect multiple local area networks to multiple hosts. The connection to the host can be made through an SDLC link or a local area network link, or both. Clients can be connected to a multi-access gateway using a variety of network strategies, including AppleTalk networks running on LocalTalk, Ethernet, and token ring. As with other types of gateways, multi-access SNA gateways slow down throughput between source and destination while converting information.

Avatar's Netway 2000 gateway is a stand-alone box that tries to minimize the performance issue by using Sun's powerful SPARC RISC chip as its processor. Netway can connect to one or two hosts through a 56 Kbit-per-second SDLC link or a token ring network. On the client side, Netway 2000 contains ports that can use AppleTalk over LocalTalk, Ethernet, and token ring networks (see Figure 10.3). Netway 2000 is also an AppleTalk router. Several models of Netway are available, offering different network port configurations at varying costs. The Netway gateway supports up to 128 simultaneous sessions, and comes with terminal emulation software for Mac and PC DOS and Windows clients.

DCA's IRMALAN/EP Gateway runs on a PC, turning it into a 3274/3276 cluster controller. Macs as well as PCs running DOS and Windows can connect to this gateway using coax cards, SDLC, or token ring. The IRMALAN/EP is compatible with AppleTalk (token ring, ethernet, and LocalTalk), Novell NetWare, and the NETBIOS PC protocol. You'll also need IRMALAN client software for your Mac.

Another gateway that supports Macs is Novell's NetWare 386 Services for SAA, a software addition to the NetWare 386 server. This gateway supports up to 1,000 sessions on a single server, and can be connected to multiple hosts. Macs need to run NetWare 3270 LAN Workstation for Macintosh. The gateway can be connected to the host using SDLC or token

ring links; LocalTalk, Ethernet, and token ring networks for clients can be connected to the server.

Figure 10.3

Avatar's Netway gateway is a multi-access, stand-alone unit between SNA and AppleTalk networks.

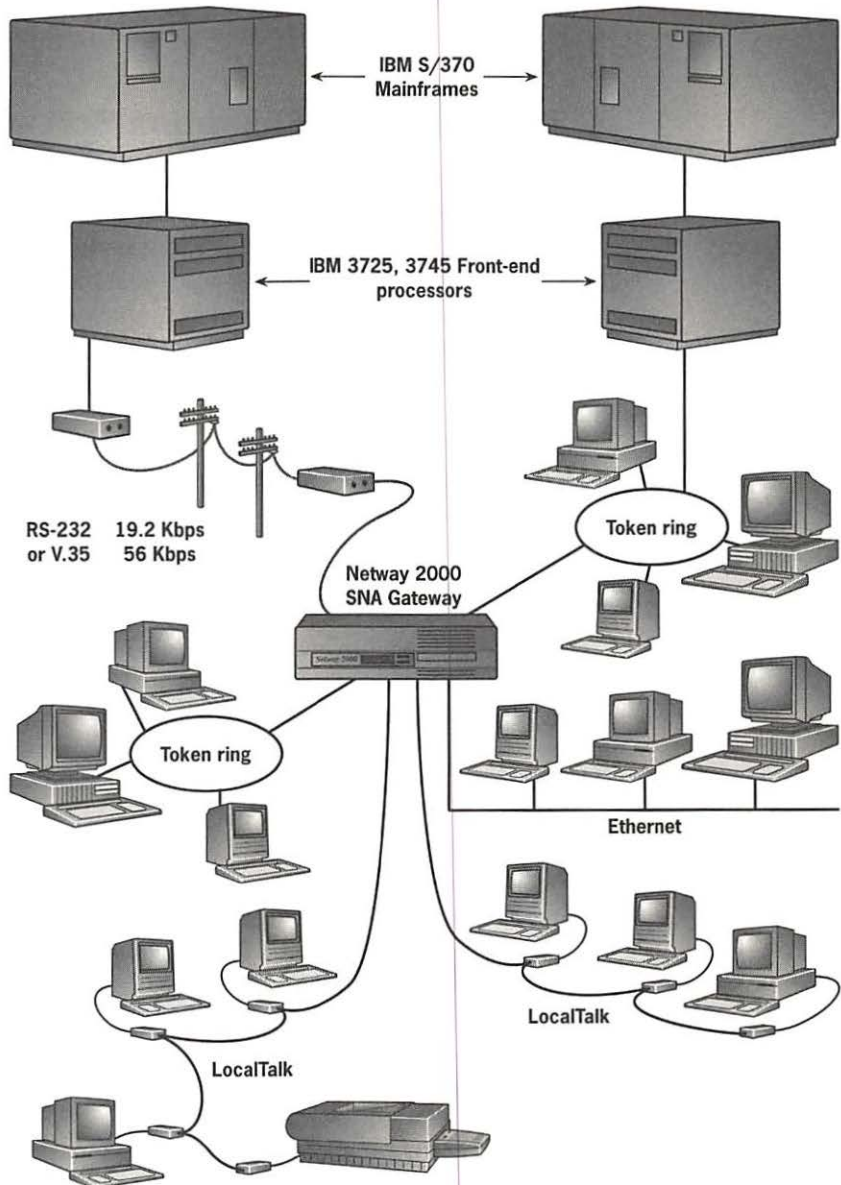

Apple offers an inexpensive AppleTalk-only SNA gateway called SNA•ps Gateway, which runs on a Mac. Like other Apple network software (AppleShare and the AppleTalk Internet Router), SNA•ps Gateway does not require a dedicated Mac, but should not be run on a workstation Mac for the sake of reliability. The gateway supports host connections through coax, serial, or token ring, and Macs through LocalTalk, Ethernet, and token ring.

■ 3270 Terminal Emulation Software

The most common way for Macs to communicate with IBM mainframes is still with 3270 terminal emulation. The 3278 or 3279 display terminal is not easy to use, but Mac emulation software usually adds features to automate processes and to make commands accessible through buttons. Mixing and matching connection hardware and 3270 software is sometimes not possible—the vendors who provide the hardware links to mainframes also supply the terminal emulation software, which sometimes is designed specifically for their hardware.

The 3278/9 terminals can run in two modes: control unit terminal (CUT) mode and distributed function terminal (DFT) mode. CUT mode terminals allow a single terminal session on screen at a time; DFT mode usually allows up to five simultaneous sessions per user, although some software can surpass that limit. Having multiple sessions up on your screen is convenient for copying and pasting text between host applications—something you can't do with a terminal—and for copying and pasting between host and Mac applications.

Some emulators come with key mapping that is sometimes implemented graphically, with the Mac and terminal keyboards displayed. To assign a terminal key to the Mac keyboard, you can use a mouse to drag a 3270 key to any key on the Mac keyboard (see Figure 10.4).

Most terminal emulation products come with the ability to do file transfers by employing a standard mainframe utility called IND\$FILE, which is used with several of IBM's mainframe operating systems. Some terminal emulation software comes with additional proprietary file transfer capabilities that are faster than IND\$FILE (though not usually any easier to pronounce). Some of these file transfer features require additional host software. Most emulation software supports the MacBinary protocol for use with IND\$FILE. MacBinary allows Mac files to retain many of their Mac attributes, such as Creator and Type codes. What follows is a rundown of the major 3270 emulation software products.

Figure 10.4

Key mapping in 3270 terminal emulation software, such as Avatar's MacMainFrame, permits click-and-drag configuration of keyboards.

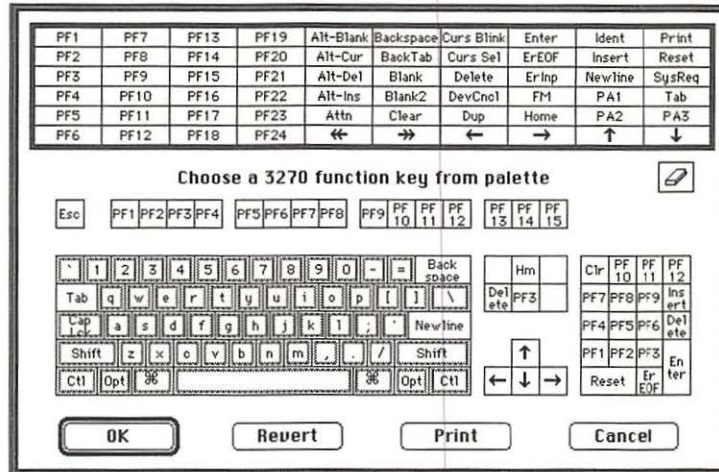

Apple's SNA•ps

SNA•ps 3270 stands for Systems Network Architecture protocols and services. SNA•ps (pronounced *snaps*) provides CUT and DFT emulation, allowing five sessions on a single Mac. SNA•ps software works over several connection methods, with the SNA•ps Gateway over AppleTalk, a direct coax connection to a mainframe, or over a serial link. SNA•ps 3270 supports key mapping, IND\$FILE file transfer, and the MacBinary format.

Avatar's MacMainFrame Software

Avatar's MacMainFrame 3270 terminal emulation software is sold alone, or bundled with the company's Netway 2000 SNA gateway, SDLC hardware, and token ring hardware. Version 5 and above supports D0 file transfers, a modification to IND\$FILE on the Mac that speeds up file transfers between Mac and host but requires no additional host software. When using Avatar hardware, MacMainFrame can make use of Avatar's proprietary MAX-DATA technology, which speeds performance by increasing the size of packets. MacMainFrame can access multiple hosts simultaneously through multiple gateways.

MacMainFrame for PathWorks is a version that enables Macs in a digital VAX environment to access IBM mainframes. A Mac establishes a 3270 link through a DECnet-to-SNA gateway running on a VAX. The VAX host can connect to one or more IBM mainframes through an SDLC link. Another product, TN3270, establishes a Telnet-like 3270 session over TCP/IP without using IBM's SNA protocol. The 3270 data is encapsulated.

Avatar also offers MacMainFrame Graphics, a DFT emulator of IBM 3179G and 3192G graphics terminals. Users can access mainframe software that uses IBM's All Points Addressable (APA) display language. You can access mainframe files in Graphics Display Format and PC Interchange Format and convert them to Mac PICT files. Each of the five host sessions can be either a graphic, text, or a printer session. The software speeds performance by allowing the Mac to process some of the graphics, thereby cutting down on packet traffic. MacMainFrame Graphics requires MacMainFrame Workstation or Gateway products to access the host.

DCA's IRMA

DCA's IRMA WorkStation for Macintosh terminal emulation software works over coaxial connections, token ring, or SNA gateways, supplying CUT and DFT emulation (see Figure 10.5). It also enables Macs to communicate with IBM OS/2 EE servers on a token ring network. In addition to IND\$FILE file transfer, IRMA WorkStation supports two proprietary mainframe file transfer methods. IRMA WorkStation for Macintosh supports DataViz's MacLinkPlus file translators from within the terminal emulation program, to enable Mac users to share files with PC users through the mainframe.

Figure 10.5

DCA's IRMA WorkStation for Macintosh is a full-featured, multisession 3270 terminal emulator. A graphics add-on emulates IBM 3179G and 3192G graphics terminals.

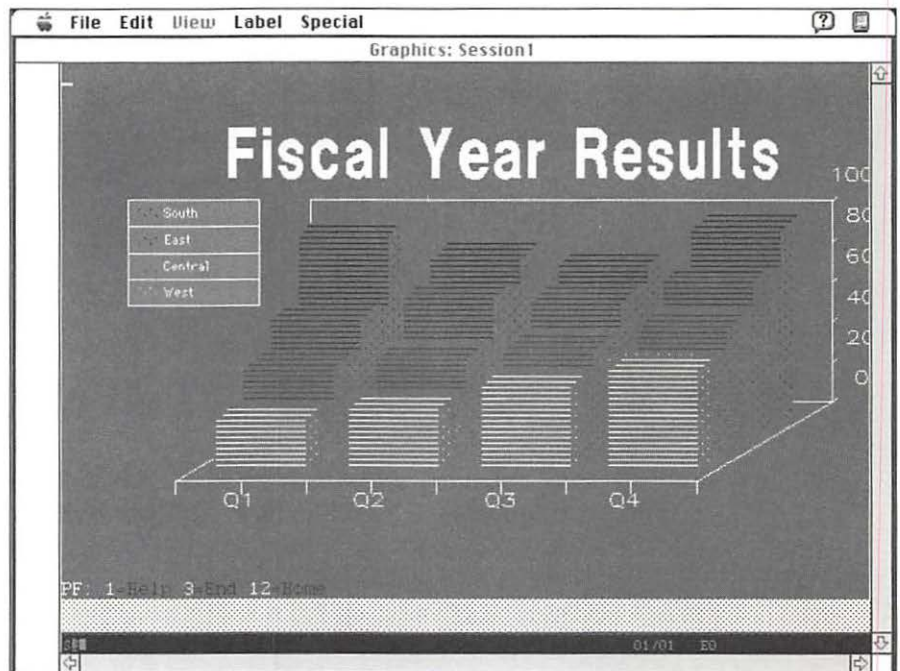

IRMA Graphics for Macintosh is an add-on to IRMA WorkStation that emulates the IBM 3179G and 3192G graphics terminals. As with MacMain-Frame Graphics, you can run APA-compatible mainframe applications such as SAS/Graph, a statistical graphing program, and IBM's Interactive Chart Utility. Mainframe graphics can be saved on the Mac as PIF files. MacIRMA Graphics supports DFT for multiple graphics sessions.

Novell

Novell's 3270 LAN Workstation for Macintosh is a newcomer in the Mac 3270 market and works with Novell's NetWare Services for SAA, mentioned above. The software supports up to 26 concurrent sessions on a single Mac and can connect to multiple hosts. 3270 LAN Workstation for Macintosh also supports IBM's LU6.2 protocol (described below). A graphical keyboard mapping utility and a tear-off keypad for terminal function keys are included. (A tear-off item can be detached from the menu bar to "float" on the desktop.) Users can customize the font size and color of a host session. IND\$FILE and NVL\$FILE mainframe file transfer utilities are supported. Links for host sessions can be made over LocalTalk, Ethernet, and token ring.

Simware's SimMac

The strong point of Simware's SimMac is its linking versatility: It will work with almost any type of mainframe connection. SimMac works with coax and SDLC boards and gateways from Avatar, DCA, and Apple, including the SNA•ps Gateway. For remote users, SimMac supports asynchronous links with Simware's mainframe protocol converter or a standard hardware protocol converter. (An asynchronous-only version is also available.) SimMac sessions can also be made over the X.25 protocol. The emulator doesn't support IND\$FILE file transfer, but comes with two proprietary formats, SimXfer and FORMAC. The latter is intended for asynchronous connections, and requires Simware's SIM3278 software running on the mainframe. SimMac sports a Mac-like interface, but also comes with an extensive scripting environment for creating a Mac-like front end, as will be described in the next section.

■ Front-Ending Host Software

Even with user friendly terminal emulation software, 3270 mainframe applications are not easy to learn or use and require users to have some training under their belts. This is why in-house and commercial developers create front ends for host software. A Mac front end is an interface application running on the Mac that communicates with the application running on the mainframe. The front end can be an off-the-shelf product for a

popular host-based application such as PROFS, or a custom program created by in-house developers or consultants for enterprise applications, such as accounting or automated sales systems.

Front-ending takes the terminal data stream from the host, processes it, and feeds it to a front-end application running on the Mac. The Mac application can either simply display the data in a Mac-like manner or do additional processing. Front-ending is closer to client-server computing than is the X Window System, which puts a Mac interface on a host-driven application. Front-ending adds more processing and more control to the Mac.

Front ends can greatly automate mainframe software, reducing complicated log-in procedures to a button click. Front ends can incorporate Apple's Data Access Language for easy access to host-resident SQL databases. They can also add features not found in the original mainframe software, such as easy navigation methods, printing to Mac printers, scrolling fields, and Mac-like text editing.

The appeal of front ends to developers is that only Mac software needs to be developed, which is much easier to write than mainframe software. Custom front ends are created using application program interfaces (APIs), which are available in programmer kits from hardware manufacturers Apple, Avatar, DCA, and Novell, among others. HyperCard's HyperTalk is often used as the front-end development language by developers of both off-the-shelf and custom front ends.

Off-the-Shelf Front-End Solutions

Most off-the-shelf front ends available are written to work with one or more modules of IBM's PROFS, or OfficeVision, as it is now called. With over 2 million users worldwide, PROFS/OfficeVision is the most popular mainframe electronic mail system. PROFS/OfficeVision also contains scheduling and calendaring features that some front ends exploit. Front ends can also add features to PROFS/OfficeVision that don't exist in that product's native form.

Simware's SimVision is a front end for PROFS/OfficeVision that implements electronic mail and scheduling, as shown in Figure 10.6. SimVision will automatically download your mail and let you read and write mail messages while disconnected from the host, which is not possible using a terminal emulator to access PROFS. SimVision adds the Mac-like feature of enabling you to create lists of users and groups for addressing mail messages. SimVision was completely written in Simware's SimMac software (described later in the chapter), and can be altered to fit the user's needs.

MacPROFF from Mariette Systems International recreates many of the PROFS screens so it is a good front end for experienced PROFS users. It adds Mac-like screen editing, the ability to send Mac text files as PROFS

notes, and the ability to display and send multipage PROFS notes from a scrolling field.

Two other PROFS/OfficeVision front ends for the Mac are MitemVision from Mitem and Executive Workstation from MediaWorks; both were created in HyperCard and provide easy navigation between different sections of PROFS. One advantage to a HyperCard-based program is that the code is completely open, so that anyone can use the object-oriented HyperTalk language to modify the interface or functionality of the program. Like SimVision, these programs come with tools for changing the look and feel of the front end.

Figure 10.6

An off-the-shelf front end such as SimWare's SimVision can turn an arcane host-based program—for example, IBM's OfficeVision—into an easy-to-use Mac program.

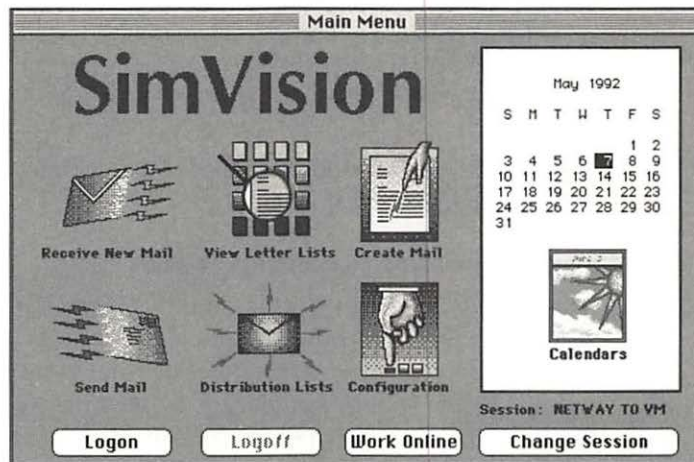

Front-End Development

There are two basic methods you can use to create a front end to a mainframe application. The first is to write to an API that comes with the communications hardware. These APIs usually contain IBM's High Level Language Application Program Interface (HLLAPI), a standard for guiding the application through the Mac to the mainframe link. The second way to create a front end is to use a hardware-independent programming environment that intercepts the data stream itself. These products provide a somewhat automated programming procedure.

Working with APIs

APIs prevent front-end developers from having to completely invent the connectivity mechanisms through hardware. APIs are open standards, so a Mac application with the ability to call an external routine can make use of an

API. Applications with this ability include Acius's 4th Dimension, Blyth's Omnis 7, and HyperCard.

As already noted, HyperCard is particularly popular with developers for creating front ends. HyperCard's popularity in off-the-shelf front ends has to do with its friendly programming language, HyperTalk. SuperCard, a competitor of HyperCard, also uses the HyperTalk language and can be used to create front ends. Non-HyperTalk code, written in many standard languages such as C and Pascal, can be linked to HyperCard in the form of external functions and commands called XFCNs and XCMDs.

Avatar, DCA, and Novell supply HLLAPI-compatible HyperCard XFCNs and XCMDs for use with mainframe front ends. FrontCard is Avatar's HyperCard-based programmers' toolkit. Specific 3270 XCMDs and XFCNs provide functions such as file transfer, keyboard mapping, and checking for host errors. In addition to HyperCard, FrontCard includes a 3270 terminal emulation window, which can be made available to developers or users.

Avatar, DCA, and Novell also provide non-HyperCard-specific programmer kits. Avatar's is called the MacMainFrame Programmers Toolkit; the DCA MacIRMA Developers Toolkit comes with HyperCard extensions, but a variety of languages can be used.

Using Applications to Build Front Ends

During a 3270 host session, the mainframe application sends a series of screens to be displayed on the terminal or emulator. Applications for front-end development capture 3270 screens as they come in from the terminal data stream. The application recognizes one or more screens, and creates an appropriate Mac front-end screen that the developer has made to replace the terminal screens. The exact procedure varies from product to product. Products in this category include Both from Connectivité, MitemView from Mitem, Blacksmith from CEL Software, and SimMac from Simware. Each supports a variety of Mac-to-mainframe connection hardware.

Both from Connectivité contains a set of algorithms that identifies and labels incoming terminal screens and saves them to disk for use in the authoring mode. The basic procedure for creating a front end with Both is to capture 3270 screens with a built-in terminal emulator, identify fields and attributes, and add graphic elements and methods of navigating through the host application to the front-end interface. Much of this procedure is done with a point-and-click object-oriented programming environment, making Both a good product for creating quick prototypes. Both 3.0 or later also supports 5250 terminal emulation for IBM's AS/400 midrange hosts. In fact, you can use Both to create a single front-end application that combines—into a single screen—multiple sessions from both types of hosts.

MitemView uses HyperCard or SuperCard and the HyperTalk language to create the front end interface. The developer first creates the user interface in HyperCard, and then collects a database of terminal screens. MitemView's pattern-matching engine, WHOOP, recognizes the state of the host application and sends messages to HyperCard, telling it to invoke the appropriate subroutine. MitemView supports Apple events, so that standard Mac applications could contact the MitemView front end, ask it to log onto a mainframe, and automatically search for a set of data on the host. MitemView front ends can also be created for applications running on Digital VAX and Tandem hosts through asynchronous connections.

Blacksmith from CEL Software is similar to MitemView, generating a user interface in either HyperCard, 4th Dimension, C, or Pascal. Interfaces created in these environments are interchangeable with the others. Like MitemView, Blacksmith recognizes terminal screens and sends messages to HyperCard or 4th Dimension. Blacksmith can also automatically select an appropriate response to be sent back to the mainframe.

SimMac, described above as a terminal emulator, also comes with a rich front-ending environment. SimMac uses Simware's own Advantage programming language to capture elements from the data stream, regardless of the type of connection. The Views feature is used to create the actual graphical screens displayed to the user. Views supports buttons, scrollable fields, dialog boxes, and nonmodal (resizable and movable) windows. The graphics screens you create can be used with the PC version of the program, SimPC. This is an important feature, since very few mainframe sites use Macs exclusively.

■ Client-Server Computing in the Mainframe Environment

The next step up the computing evolutionary ladder from front-ending is true client-server computing. Figure 10.7 shows a chart representing some of the trade-offs encountered as you move from terminal emulation to client-server computing. The closer to client-server you move, the more power and ease of use you give to the user, and the more complex the system gets. Personal computers, which are relatively simple systems, can handle client-server complexity without much trouble for the system designer. The IBM mainframe world is not quite there yet.

Since the spread of personal computers began in the 1980s, IBM has been adding protocols to SNA to allow for client-server computing and peer-to-peer communications—the ability of PCs within SNA to communicate with each other without going through the host. But change occurs slowly in the mainframe world, mostly because of the high complexity and cost of the

hardware and software. Client-server computing in the IBM mainframe environment is not as far along as it is in the VAX environment.

Figure 10.7

As you move from terminal to client-server computing, the complexity of the software increases, but the user training requirements go down, until you have the user working in a completely native environment.

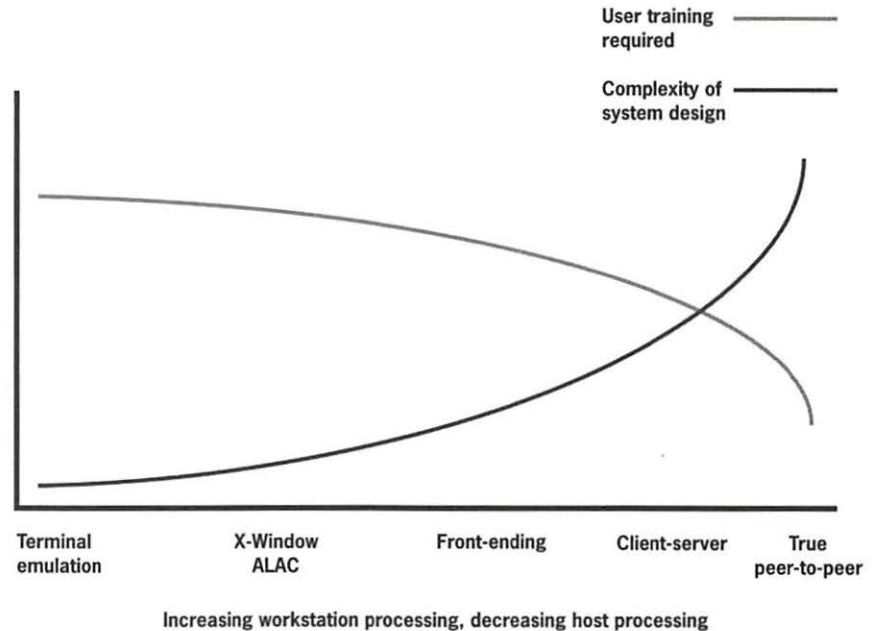

Although there is no complete client-server SNA solution such as an IBM equivalent to Digital's PathWorks, there are some pieces detailed below that can be put into effect now or in the near future.

Apple MacAPPC

An important part of IBM's plans for peer-to-peer computing in SNA is Advanced Program-to-Program Communications (APPC). APPC is implemented through a protocol called LU 6.2/PU 2.1. APPC allows devices to communicate directly with each other rather than having to pass through the host. Applications that implement LU 6.2/PU 2.1 will be able to communicate with other LU 6.2 applications anywhere on the network, without the user having to know where they are. However, directory and routing services are still needed to make these types of communications automatic.

Apple's MacAPPC is a package that helps developers create APPC-compliant applications that can access information anywhere in an SNA environment, regardless of the type of computer or location. MacAPPC implements

the LU 6.2 peer-to-peer protocol on the Mac as a system extension and provides tools to create distributed applications for transparent access to data.

Several SNA products for Mac are APPC-aware. Apple's SNA•ps Gateway and Token Ring 4/16 NB Card support APPC for Macintosh clients. Third-party products such as Novell's NetWare 386 Services for SAA support APPC as well.

Apple Data Access Language (DAL)

DAL is a database connectivity language that allows Mac applications to extract data from an ANSI-standard Structured Query Language (SQL) database on a mainframe (or any other computer). Dozens of Mac applications support DAL, so you could access a mainframe database and do a search from a dialog box within 4th Dimension, for example. The user has to know only how to run a Mac application and needs little knowledge of the mainframe. DAL servers are available for various mainframe, minicomputer, and UNIX computers. DAL and database connectivity will be discussed in more detail in Chapter 11.

IBM LAN Resource Extension and Services/VM

IBM's LAN Resource Extension and Services/VM (LANRES/VM) is a client-server solution that ties its S/370 and S/390 mainframe systems to Novell NetWare 3.11 and its SNA gateway. LANRES/VM distributes data and services down from the mainframe to local NetWare servers. LANRES/VM allows users to employ the storage facilities of the mainframe for their own disks. Clients can also use mainframe printers and access mainframe databases. The LANRES/VM system also provides the capability to administer multiple NetWare servers at one time. Macs require NetWare for Macintosh.

IBM Backup Server

IBM has a client-server solution for its ES/9000 mainframes. The IBM Workstation Data Save Facility/VL is an archival and backup server that enables a Mac, PC, or UNIX machine to directly access a mainframe for manual or automatic backup. The backup system runs on several versions of IBM's VM operating system (VM/SP Release 5 and 6, VL/XA SP Release 2 and 2.0, and VL/DSA).

A backup application sits on the Mac and opens a link to the mainframe. Backup of Macs and other workstations to the mainframe can be user initiated or automatic, and will run in the background. Backups can be full, incremental, or selective, and can be made on magnetic tape for archival storage. The connection can be made over a local area network, such as a TCP/IP

network running over token ring or Ethernet, or a wide-area network. Links can also be made over coaxial cable.

■ Accessing the Midrange

In addition to the 3270 mainframe environment that I've been describing, IBM also has a popular midrange line of hosts, consisting of the popular AS/400 and the older S/36, S/38 minicomputers. Less expensive and simpler to operate than the 3270 environment, the IBM midrange computers have spread throughout business. Since IBM introduced them in 1988, about 170,000 AS/400 hosts were estimated to have been installed by the end of 1992, according to Datamation magazine.

The midrange IBMs are different enough to require their own connectivity solutions. Communications between host and terminal is through twinax cable instead of coax cable. The IBM midrange computers use 5250 terminals, which run a different data stream than the 3270 terminals (3270 emulators can't be used). The 5250 line includes 522X printers.

Apple's Coax/Twinax card can be used to make the connection, as can the TwinAccess board from Andrew KMW, a major provider of Mac-to-midrange connectivity. The board can connect directly to the host or to a 5251 cluster controller.

NetAccess is gateway software that runs on a Mac that has a twinax board installed, enabling Macs on an AppleTalk network to access AS/400s and S/3X hosts. The Andrew KMW also offers a hardware protocol converter that allows asynchronous connections to a host and use of VT100 emulators.

Andrew KMW offers 5250 terminal emulation software, as well as an API with HyperCard extensions for creating front ends. IDEAcomm Mac from IDEA Associates is a bundle that includes a twinax board and a 5250 emulator that supports up to four host sessions as well as file transfer.

■ Looking Ahead

You've seen from the discussions of UNIX, VAX, and IBM mainframes, that Macs can make the same connections to other computers that a PC can. These connections can be made using Mac standards or industry standards, or sometimes both. You can communicate by trading files, electronic mail, and printed documents.

The answer to the question, Why do people need to make connections to big computers, is, mainly to extract a small amount of very specific data from the volumes of much more general data—that is, to make order out of chaos. To do this without requiring users to become experts on every type of

computer that runs a database, you need to get the database management software on different computers to communicate with each other and make the connections themselves, preferably in a client-server relationship. Database connectivity is the subject of the next chapter.

- *Built In: Database Hooks*
 - *Accessing Database Servers*
 - *Choosing Client Software*
 - *Entering Enterprise Computing*
-

C H A P T E R

11

Database Connectivity



DATABASE IS AN ELECTRONIC LIBRARY, AND AN APPLICATION called the database management system—like an electronic librarian—tracks the data. Perusing the data—scrolling through pages and pages of records—is not practical, so we ask the database management system to locate the data for us by performing a *query*, a request for specific data. This is the Find or Search function on some Mac-based database applications. But you're not limited to accessing databases on your own Mac or other Macs.

Databases come in all sizes. You may keep one on your hard disk to store your telephone numbers, or you may access one running on a Mac or PC occasionally to get some numbers or do some research. Or, you may use one or more mainframe database servers on a daily or even hourly basis as part of a corporate-wide enterprise system consisting of interconnected mainframes and personal computers. In any case, searching for specific data—performing a query—is usually done with a *query language*, a common set of commands that enables communication between user and database and between incompatible database software and operating systems. The most common query language used today by host database management software is Structured Query Language (SQL).

Although a query language such as SQL has the ability to extract the data you need, traditional methods of retrieving data from a mainframe required users to locate and extract data by using arcane commands and a comprehensive knowledge of how the system worked. Once the data arrived on the user's screen, the next problem would be what to do with it. The next step would be to print out data on paper, and type it into an analysis program.

Macintosh users have several options for querying databases residing on a variety of computers. Front-end applications are available or can be built to automate procedures and to hide query commands inside of on-screen buttons or menu commands. Once retrieved, data can be copied from the front-end application and pasted to an office productivity program, such as a spreadsheet, for further analysis.

An even more useful approach is to enable the applications that need the data to retrieve the information themselves. In other words, you could use the spreadsheet program itself to access the database server and extract the data you need. This is possible if the application and the database server can speak Apple's Data Access Language (DAL). Fortunately, dozens of database servers and Mac applications have this ability.

The question of database connectivity gets rather complex in *enterprise computing*, the corporate-wide information systems (IS) that are the lifeblood of an organization's operations. IBM and Digital both have guidelines for the design of an enterprise IS system for a big network of mainframes and PCs spread over large distances.

In 1992, Apple came up with VITAL, its own strategy for designing an enterprise IS system. VITAL is a blueprint for designing multiplatform cooperative client-server computing on a large scale; VITAL will be discussed later in this chapter.

Built In: Database Hooks

The System 7 operating system contains several components that hook your Mac software to databases running on other computers over a network.

These are the Data Access Manager and the Data Access Language. The Data Access Manager acts as an interface between applications and host databases. The Data Access Manager handles calls from an application and receives incoming data from a database, presenting it in a form that the application can understand. Applications that can communicate with the Data Access Manager only require a small amount of code to be able to import data from databases, enabling developers of spreadsheets or other office productivity software to add database hooks to their programs.

The Data Access Manager communicates with one or more system files—called database extensions—that send and receive commands to and from the database in a common database language. The database extension acts as the database client software that is used to communicate with a database server. To enable applications that are aware of the Data Access Manager to communicate with a specific database, you can add a database extension file that is provided by the database vendor. To enable applications to communicate with databases compatible with Apple's Data Access language, you can use the database extension that comes with System 7.

The DAL client software system extension enables applications to access DAL database servers. This extension uses Apple's Data Access Language, an SQL-compatible database-connectivity language for communicating with databases residing on other computers.

Mac applications that are DAL-compatible can make connections for you over a network to Macs, PCs, VAXes, and mainframes. The connections are transparent: You don't have to know where the data resides or anything about how the particular database management software or host operating system works. For instance, to get data, a typical DAL-compatible application would present you with a window that has a list of DAL-compatible database servers. You would click on one to select it, and DAL would make the needed connection.

Setting up DAL connections sometimes requires that you create a login script in the DAL Preferences file, a text file located in the System Folder's Preferences Folder. (This DAL Preferences file is called `hosts.cl1` in System 6.0.x.) AppleTalk connections usually don't require scripts, but other types of connections do. You may need multiple scripts for different connections. The scripts are written in the Data Access Language and are somewhat forbidding for the average user. For instance, the script for a link to an IBM mainframe running the VM operating system through DCA's MacIRMA coax card looks like this:

```
vmi:DCA:VMCMS:A:DFT:1
vmi:login:1:\mRUNNING\slogoff\r\mcontinue\r\mCOMMAND\>>\
svmexit\r:1800:4000:.\Mlogon\svm\r\mUSERID\u\>p\r\mReady
```

Not a pretty sight, particularly for a Mac user. Apple expects the database administrators and in-house developers to set up the DAL scripts for the users, though a few DAL-compatible client applications will create this file for you. The sample DAL Preferences file that comes with System 7 contains many sample scripts for different host connections. You'll have to edit these scripts, because they contain information specific to your setup, such as in which NuBus slot your interface card is sitting. Apple's *Data Access Language for the Macintosh Installation and User's Guide* also offers some tips on installing DAL.

■ Accessing Database Servers

Unlike single-user database programs, multiuser databases are often based on a client-server structure, which separates the database management software on the host from the retrieval software on the client. As mentioned in Chapter 7, a database server differs from a database application running on a file server in function and performance. A database application sitting on a file server is the slower of the two, because the file server does not know where your data is in the database. Consequently, when you send a query, the file server will send either the entire database over the network to your Mac, or send keys for every record in the database. A database server, on the other hand, keeps track of where the data is, and sends only the information you've asked for. For this reason, database servers can be one or two orders of magnitude faster than databases on file servers. The reason why PC-based mail systems tend to be slower than Mac-based servers is that PC electronic mail programs are usually database files sitting on a file server, while the Mac mail programs are database servers, serving up mail messages to users who are clients.

Query Languages

In addition to using DAL, Macs can also access database servers through a database extension that is supplied by a third-party vendor or written in-house. You can also bypass the Data Access Manager to write a specialized database client application, but this is not as common. With any of these methods, queries from the client are sent to database servers using a common query language. The most common is the Structured Query Language, commonly known as SQL, pronounced like the word *sequel*.

SQL was originally developed by IBM in the late 1970s for its own mainframe systems, but has been adopted by the major database management system manufacturers. SQL is widely used on database servers on mainframes, minicomputers, and personal computers. SQL provides commands for

manipulating databases, including retrieving, modifying, adding, and deleting records in a database. Hosts can also send SQL commands to each other to automatically transfer and update data.

A front-end application written to an application program interface (API) translates the actions of buttons and menus into SQL query commands. APIs for building a Mac front end are available from many database vendors, and some vendors offer completed front ends. A drawback to using APIs other than DAL is that they are usually specialized for one particular database. Although they all use SQL, there are differences in syntax, which prevent the same API from being used for different database servers. If you need to access more than one type of server, you'll need a front end written with each different API (see Figure 11.1).

Figure 11.1

You can use a non-DAL API to write Mac client software for a host database, but you'll need an API for each type of database.

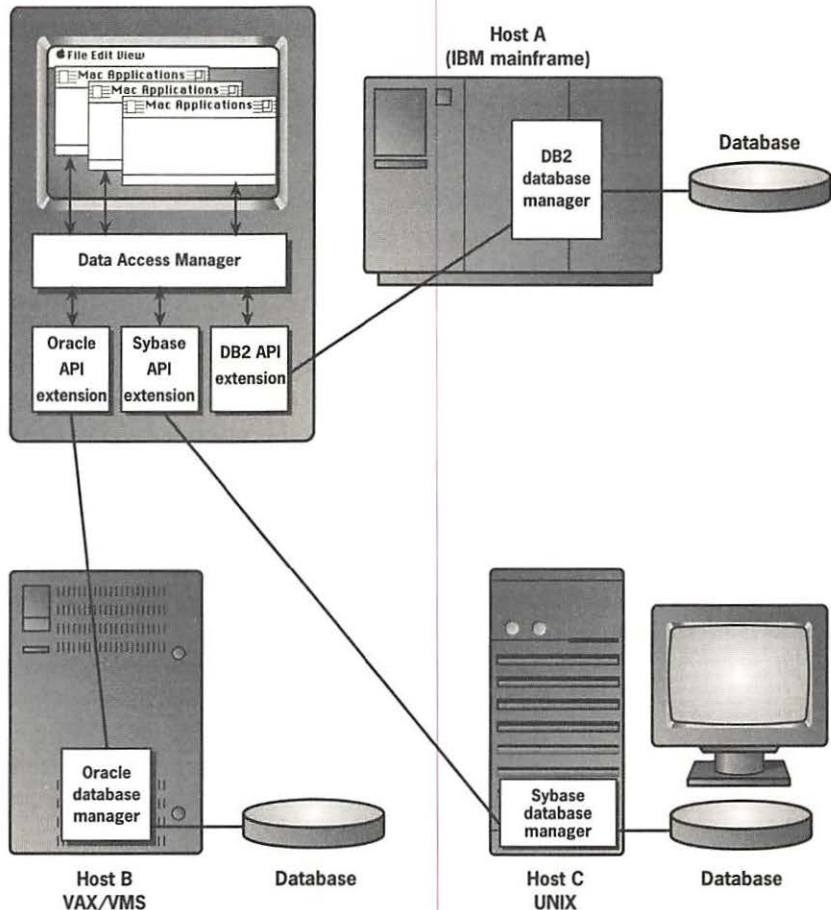

Using a non-DAL API is a good approach for creating data entry applications, where few screens are required. HyperCard extensions can be used to quickly create a front-end data entry application with snappy performance.

Apple's Data Access Language

DAL is a connectivity language that communicates between Mac applications and SQL database servers. DAL has several advantages over using proprietary APIs. First, the front-end application doesn't have to be specially written. Ordinary business applications such as spreadsheets that are DAL-compatible can access host data using DAL. DAL is also more flexible than other APIs because DAL-compatible applications can access any DAL-compatible server, not just one brand of database. Dozens of DAL-compatible server and client applications are available.

DAL uses basic SQL commands, and adds some capabilities as well. DAL adds a method of naming and listing databases in a standard manner, so that the user can deal with different database servers in a uniform manner. DAL performs the host connection, automating the connection procedures so that you don't even have to know what host you are getting data from or what type of computer the data is on. The Mac application is insulated from the differences in mainframe systems, database management systems, and networks.

DAL adds procedures to control the database server software, which enables data manipulation, processing of results of queries, and managing the output. DAL provides the password protection required by the hosts and database management system.

DAL client software doesn't speak directly with the database server; it speaks with a DAL server, a piece of software running on the host that turns an existing SQL database application into a DAL-compatible database application (see Figure 11.2). The DAL server translates DAL queries it receives from a client into the native SQL commands of the database. The database server processes the query, and returns the data to the DAL server, which formats the data into a form that the DAL client software can use. Thus, the application on the client asking for the data never even sees the host database server.

A DAL server can service multiple databases running on a host. DAL servers exist that run on all kinds of machines—Mac, PC, UNIX, VAX and other minicomputers, and IBM mainframes. You need to buy a version of a DAL server specifically for the host operating system and hardware platform. Database servers that run on Macs and PCs often come with the DAL server.

DAL's major drawback is that all this user friendliness renders it a slower method of accessing host data than using another API. MacUser Labs

testing on a VAX running an ORACLE database server showed DAL performance lagging behind that of SQL*NET from ORACLE and SequeLink APIs from Technosis. The ratio of the difference in performance between SQL*NET and DAL was over two-to-one in some cases, both in making a connection to the host and downloading data.

Figure 11.2

A DAL server is software that runs on a host to enable DAL clients to access an SQL database. A DAL client is universal and connects to different types of hosts, operating systems, and databases.

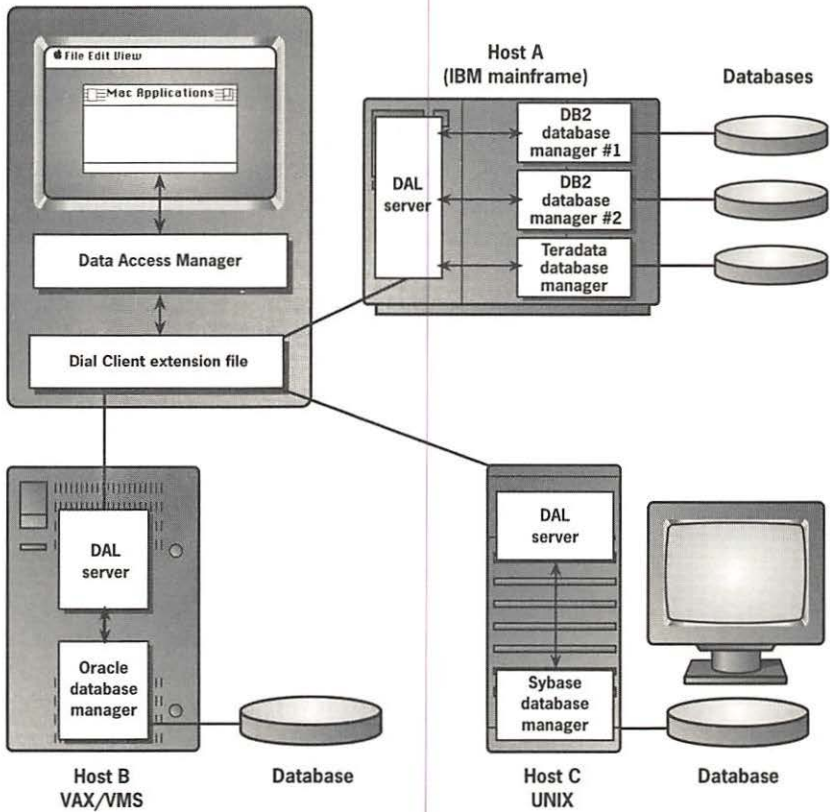

Mac-Accessible Database Servers

There is a wide variety of database servers that Macs can access using non-DAL APIs or DAL, or sometimes both. These include the biggest names in SQL databases, including Sybase, Informix, ORACLE, DB2, and Rdb. Macs can access servers running on other Macs, PCs, and UNIX workstations, as well as mainframes.

Mac Servers

Database servers running on a Mac are useful in small organizations with limited resources, and in large organizations where the Mac acts as a local workgroup server. In the latter case, the Mac server would augment a mainframe database server. Users would access only the local Mac server, which would be programmed to gather data from the mainframe database if needed. The mainframe could also be programmed to automatically update the local Mac server on a periodic basis.

The benefits and drawbacks of running a database server on a Mac are similar to those discussed in Chapter 7 for file servers. Database servers on Macs are easy to set up and maintain. They're also very economical, because database server software for the Mac costs a great deal less than mini-computer or UNIX workstation software, and Mac database servers don't require a high degree of expertise to administer. The main drawback is that the Mac operating system is optimized for end users and not for use as a server; the Mac OS lacks preemptive multitasking (as discussed in Chapter 7). In addition, the user interface features are unnecessary overhead for a server application.

Traditional Macintosh multiuser database applications, such as 4th Dimension, FoxBASE, and Omnis, were not database servers, but databases running on file servers. It is only more recently that some of these companies have been putting out database servers for the Mac. In the meantime, other companies have begun offering Mac-based database servers, some of which use DAL, some of which don't.

ACIUS sells both client and server software as part of its 4th Dimension line of database products. The 4D Server package also comes with the 4D Workstation client software. The client software is very similar to the ordinary 4th Dimension software, but is optimized to run with the 4D Server. In fact, server and client software act as one integrated system working over a network. (ACIUS supplies their own database extension for your System folder.) The 4D Server is highly optimized for performance, running many times faster than a DAL server. Because both the client and the server speak the same proprietary language, there is no language translation needed on the host or the client. 4D Server also supports very large RAM caches, reducing the need to access the hard disk.

To get around the deficiencies of the Mac operating system, the 4D Server also has its own real preemptive multitasking system within the server, similar to the way Sybase works on the VAX. This means that once the server is running, it does its own time slicing, and doesn't use the Mac OS when switching processing between users. One of the benefits of the server architecture is that it lets you modify the design of your database while users

are logged on. 4D Server is also one of the easiest database servers to set up, start up, and administer.

Butler from EveryWare Development Corporation is a Mac-based database server with a built-in DAL server. Butler became the first DAL server to run on a Macintosh when it was introduced in early 1992. Client software can be any DAL-compatible application. However, Butler replaces the DAL Preferences file with its own preferences file, which can be created by mouse clicks instead of by typing lines of code. Butler also extends DAL, allowing users to create a database and to store pictures and sound. Butler doesn't require a dedicated Mac and can run on the same Mac with a file or mail server. Butler supports the Communications Toolbox (see Chapter 9) for connections to clients and other servers. In addition, the server makes use of System 7's program linking to create client-server links over serial lines. Butler requires System 7.0 or later on the server.

ORACLE, one of the biggest providers of host databases, also has a version that runs on the Mac. Although ORACLE's mainframe database servers support DAL, the ORACLE Server for Macintosh doesn't. Instead, you connect through one of ORACLE's HyperCard front ends, or build one of your own with ORACLE's API kits, such as ORACLE for 4th Dimension. The Mac client requires SQL*NET AppleTalk software (provided with ORACLE Server for Macintosh). Although the client software can't access any other brands of database server, it can be used to access other ORACLE servers running on minicomputers and mainframes. Like Butler, ORACLE for Macintosh doesn't require a dedicated Mac, but you might want to dedicate a Mac to get optimal performance.

PC Servers

PC-based database servers are usually found on a server running one of the big network operating systems, such as Novell NetWare. These database servers cost more than Mac-based servers and are more difficult to set up and maintain, but provide advantages in data security and reliability.

Several database servers are available for Novell NetWare. These are installed on the same PC that runs the other network services, such as file serving and electronic mail. Novell's database server is called NetWare/SQL and is DAL-compatible. ORACLE also offers a version of its server for Novell NetWare, as well as for OS/2. Both of the ORACLE servers include support for the ADSP protocol for quick transport over AppleTalk networks.

UNIX

The next step up in price, performance, and complexity for SQL database servers is UNIX-based computers. Pacer's DAL Server for UNIX enables DAL applications to query a variety of databases running on Sun's SPARC

workstation, a high-performance RISC-based computer that is one of the most popular UNIX platforms. Pacer's DAL Server for UNIX supports database servers from ORACLE, Informix, and Sybase. Pacer also has a version for the Hewlett-Packard 9000, series 800 UNIX workstation. Mac clients can access the Pacer DAL Server as participating nodes on a TCP/IP network, or through an AppleTalk gateway.

The ACIUS 4D SQL Server is a proprietary link between 4th Dimension on the Mac and Sybase running on UNIX workstations. An installer program is run on the client Macs to install new code into the Mac's 4D software. The result is a faster link than a DAL connection.

VAX and IBM Mainframes

Most of the major databases running on Digital VAX systems and IBM mainframes are supported by DAL servers. There are also APIs available for the same databases.

Apple's Data Access Language Server for VMS supports Digital's Rdb/VMS database, as well as ORACLE, Ingres, Informix/SQL, and SYBASE databases. DAL on a VAX requires VMS 4.7 or higher. For IBM mainframes, Apple offers the Data Access Language Server for VMD/CMS for the SQL/DS database server, and the Data Access Language Server for MVS/TSO for the DB2 database application. Access to the IBM servers can be through 3270 sessions, TCP/IP networks, or asynchronous links. Connections can be SNA or non-SNA.

API solutions are also offered from individual database management software vendors. Digital's SQL/Services for Macintosh is a development environment for Mac client applications communicating with Digital's VAX Rdb/VMS database. Client applications use DECnet to communicate with the VAX database server. By using Digital's VAX-IBM Data Access software, applications written with SQL/Services can also access IBM's DB2 mainframe database.

The Sybase API for Macintosh enables Macs to access Sybase databases that are up to several gigabytes in size. Macs connect to the database server over TCP/IP and Ethernet. ORACLE's SQL/net API will allow clients to access databases running on the VAX/VMS and IBM MVS and VM operating systems.

Other Hosts

Tandem hosts are built for on-line transaction processing used in financial institutions as well as in retail and manufacturing settings. Tandem-based systems use SQL databases distributed over a network on multiple hosts. Many of the automatic teller machines that dispense cash outside of banks run on Tandem computer systems.

Tandem's Data Access Language Server gives Mac applications access to the Tandem NonStop SQL databases, which run on Tandem's Guardian operating system. The NonStop system is a sophisticated, performance-driven system featuring parallel processing and distribution of applications and data over the Tandem network. Transactions made through DAL are fully protected by Tandem's Transaction Monitoring Facility, which removes uncompleted transactions and restores damaged databases.

Although Macs can access Tandem computers through TCP/IP networks or asynchronous connections, the Tandem DAL Server also adds AppleTalk through the use of TandemTalk, host software which is very similar to AppleTalk for VMS on the VAX platform. Macs can access Tandem computers through an Ethernet controller added to the Tandem system.

The Teradata DBC/1012 Data Base Computer is a powerful, parallel processing machine designed to be used as a database warehouse that supplies data to other hosts, including mainframes from IBM, UNISYS, Digital, Hewlett-Packard, and Pyramid. Macs can have indirect access to the Teradata through DAL servers for the supported hosts. Teradata also offers a direct API, the Teradata Client/Server for Macintosh. Client software can be developed in HyperCard, Excel, and C. Macs can communicate with the DBC/1012 on a TCP/IP network over Ethernet.

■ Choosing Client Software

In addition to the wide variety of DAL servers, DAL enables you to use a wide variety of client applications. Not only can the clients fetch data from databases, but they also perform analyses and graphically represent the data to help you better understand it. Most of these clients support DAL. Some clients advertise compatibility with the Data Access Manager, which means they support third-party APIs as well.

There are basically three categories of DAL or DAM client applications: off-the-shelf general purpose Mac applications with built-in DAL capabilities, off-the-shelf DAL-compatible software specifically designed for retrieving and manipulating data, and more vertical applications that you build yourself. For this last option, Apple supplies toolkits to build your own DAL client software in HyperCard, C, and Pascal. For a mixed environment of PCs and Macs, Blyth has products that add DAL client support to PCs running Microsoft Windows and OS/2, allowing these operating systems to access any DAL server. Mainframe front-ending development tools discussed in the last chapter can also be used for non-DAL connections.

Office Productivity Applications

Excel, Lotus 1-2-3 for Macintosh, HyperCard, and 4th Dimension are all DAL-compatible. HyperCard first became a popular DAL application because of its user-friendly HyperTalk language and extensions to other languages. However, as client software, HyperCard has limited usefulness; it can display data, but little else. Spreadsheets, particularly Excel, are being used more frequently as DAL clients by in-house developers, because of what can be done with the data—namely, analyzed, graphed, and put into an attractive presentation—once it is retrieved. Spreadsheets also use a common interface with which most office workers are familiar.

The Mac database programs are less turnkey. 4th Dimension has long been a provider of tools that enable it to act as a powerful client to foreign databases. 4th Dimension includes an integrated application development environment with a high-level language and optional compiler, but also offers functionality right out of the box. In addition, optional modules for spreadsheet graphing, drawing, and other functions make it a rich data analysis tool for downloaded data.

Developers' tools also allow simultaneous connections to multiple hosts. The 4th Dimension developer kit, called 4D D.A.L., goes beyond DAL's basic command set with its own SQL tools. In addition to its ability to act as client software to access DAL servers for the major database servers, 4th Dimension can be used to develop host database applications with Sybase on VAX, Sun, and Hewlett-Packard computers over TCP/IP and DECnet networks.

Starting with version 5, Omnis from Blyth is another database program that makes a good DAL client. Omnis started out as a PC database product, but the Omnis 7 release incorporated many Macintosh features. Applications created with Omnis can be moved easily to PCs running OS/2 and Windows, making Omnis a good choice for mixed environments.

Specialized Query Applications

Several end-user applications have been written specifically to gather data from host database servers. They vary in the amount of development they require. The more highly customizable packages tend to be aimed at large sites where a tailored query application is desired for a large number of users. The more turnkey packages are useful for individuals or small numbers of users who need occasional access to host data. Unlike the programming tools mentioned in the previous section, customization with these tools is done mostly by manipulating a graphics interface rather than by programming lines of code.

Andyne's GQL is a series of user and developer tools for database administrators to create custom end-user query tools. GQL uses graphical

tools to create graphical front ends that can access host databases through DAL and proprietary links. Figure 11.3 shows an end-user application. The front window shows a query builder that enables the user to create relationships between database tables of records and fields. Frequently used queries can be represented as buttons (shown at the right). The query results are displayed in the top window, and a report is shown in the window to the right. An optional module enables users to modify host data.

Figure 11.3

Applications written specifically for host database queries, such as Andyne's GQL, offer transparent connection to hosts, icon-based query generators, and reports on the retrieved data.

The screenshot displays the GQL Version 3.0 interface. The main window, titled "Query Results 11", shows a table of sales data for NY. The table has columns for State, City, Date, and Amount. The data is as follows:

State	City	Date	Amount
16 NY	Ribany	11/25/1984	245 6700
17 NY	Ribany	12/01/1984	2348 3400
18 NY	Englishtown	12/06/1984	120000 0000
19 NY	Hempstead	10/13/1984	67000 0000
20 NY	Hempstead	04/23/1984	86970 0000

A separate window titled "USA Sales Information" displays an "Ad hoc Queries" diagram. The diagram shows relationships between entities: "customer" (represented by a person icon) is "placed" with "order" (represented by a dollar sign icon). "customer" is "assigned to" "salesman" (represented by a person icon). "salesman" "works at" "office" (represented by a building icon). "salesman" is "sold" "order".

To the right, a "Query Results 11" window shows a "USA Sales Summary" report for Wed, May 13, 1992. The report includes a table of sales by date and amount:

Date	Amount
10/1984	\$12,000.00
5/1984	\$5,397.75
5/1984	\$2,468.74
1 Sales	\$19,866.49
10/1984	\$23,450.00
5/1984	\$8,750.46
7/1984	\$120,000.00
3/1984	\$50,000.00
12/1984	\$42,800.00
4/1984	\$9,834.34
2/1984	\$4,230.30
1 Sales	\$259,065.10
5/1985	\$2,956.84
23/1984	\$2,345.75
7/1985	\$3,875.44
10/1984	\$22,350.00
5/1984	\$15,879.89
1 Sales	\$47,407.92
5/1984	\$245.67
1/1984	\$2,348.34
6/1984	\$120,000.00
3/1984	\$67,000.00
23/1984	\$86,970.00

Below the report is a panel of "Executive Buttons" including "Customer List", "Large Orders", and "Sales by City". There are also icons for a report, a bar chart, and a map of the USA.

ClearAccess (from the company of the same name) is an Apple Menu item that makes all the connections to SQL database servers and performs queries. With the ClearAccess query builder, users can click on choices to record query steps in macro-like scripts. ClearAccess can be used in conjunction with programs such as spreadsheets to enable collected data to flow into standard productivity applications. Data can also be saved in spreadsheet file formats. ClearAccess works with or without DAL. System extension files, one for each specific database server, connect to SQL servers that are not running a DAL server. The extensions translate ClearAccess queries into SQL formats, then send them to database servers. A Windows version of ClearAccess is also available.

Brio's Data Prism is an end-user query tool that requires little or no customization. Connections can be made through DAL and database APIs, such as ORACLE's SQL*NET. Data can also be imported from other Mac applications. Data Prism features a very clean interface that can be learned in a matter of minutes. After making a connection to the database server, Data Prism lets users select which fields from the database they are interested in and then perform a query. Data Prism can export data to other Mac applications for analysis. A good companion product to Data Prism is Data Pivot, a multidimensional data analysis tool. Data can be imported into Data Pivot with the click of a mouse button. Data Pivot displays data in a spreadsheet-like table, and allows users to switch rows and columns by clicking and dragging one over to the other. Data Pivot will display as many or as few variables as needed at once, all of which can be rearranged instantly. Another Brio program, Data Edit, enables users to make changes to host databases.

Occam's Muse is another off-the-shelf program that features click-and-drag rearrangement of multidimensional tabular data. After data has been loaded into Muse's database, data can be selected using a variety of methods. Muse has the most English-like query commands I have seen, with a natural syntax and vocabulary that can be extended by the user. A typical query statement for data already loaded into Muse would be "Get me the sales for tractors for 1993 for Iowa and Kansas." However, learning Muse takes some effort, for it has a much more complex interface than does Brio's Data Pivot.

Data on the Map

Another class of DAL-compatible Mac applications request data from a host and plot it on geographic maps. These applications help you visualize pages of numbers by plotting individual points as symbols or by shading regions to represent different values. Plotting data on a map can bring out trends that you can easily miss when you just look at the numbers. Depending on the software, you can display data on a national, state, local, or even street level, though more detailed maps are offered as options. Tables and bar graphs can sometimes accompany the data presented in maps. Some products allow you to overlay different sets of data on a map so you can make comparisons. DAL-compatible geographical analysis applications include Atlas Pro from Strategic Mapping, GeoQuery from GeoQuery Corporation, MapInfo from MapInfo Corporation, and Tactician from Tactics International.

■ Entering Enterprise Computing

In a large enterprise-wide system, the mainframe-based databases that make up a corporate-wide information system (IS) are the lifeblood of an

organization's operations. Information is acquired, processed, and retrieved in applications such as customer call tracking, employee directories, and manufacturing and sales inventories. Information can be updated and retrieved on a monthly basis or as frequently as several times an hour. Much of the complex software is written in-house or by consultants using the database languages of the big mainframe database management systems.

To help their customers tie IS software systems together with their networks of PCs, the major mainframe manufacturers have come up with design guidelines for enterprise systems. IBM's is the Systems Application Architecture (SAA), and Digital's is called Network Applications Support (NAS). Although Apple doesn't plan to enter the mainframe market, it has its own plan for designing enterprise systems. Apple's plan, VITAL—Virtually Integrated Technical Architecture Lifecycle—is based on peer-to-peer collaborative computing. Both desktop and host applications can access databases. VITAL doesn't replace SAA or NAS, but it is compatible with them. The goal of VITAL is to supply a consistent interface to users, a consistent application program interface (API) to in-house developers, and the ability to select any platform for IS managers.

VITAL is neither software nor hardware, but is rather a blueprint to create IS applications used to collect, store, process, and access data on a multiplatform, multinetwork system of Macs, PCs, workstations, minicomputers, and mainframes. Apple provides some technical assistance and dozens of design flow charts called templates that outline the design for a variety of different IS situations.

Apple originally developed VITAL for its own internal IS needs. Like other growing companies, Apple installed the latest computer products to manage such enterprise tasks as customer tracking and employee payroll. In addition to Macs, the system included all kinds of big and small computers, and state-of-the-art network and connectivity hardware and software to tie it all together. Unfortunately, Apple found that the hodgepodge approach produced unforeseen bottlenecks that bogged down the system. In addition, in-house IS software developers were allocating major resources to make small changes, and users required expert knowledge to access the information they needed. Not surprisingly, these were the same types of problems Apple's customers were having. After working with its customers and the major mainframe manufacturers, Apple formed the Enterprise Systems Division to promote the VITAL model among its customers and to potential new customers.

VITAL is not exactly the most elegant acronym to roll out of Silicon Valley. A key word is *virtually*, because shared data appears to the users to be from a single source, but actually may be scattered across a network on incompatible computers and applications. The word *lifecycle* in the name is

meant to indicate that the VITAL system is a modular, ever evolving one, unlike the static mainframe-centered systems it is meant to replace. VITAL doesn't dictate which computers, networks, or standards you use; VITAL is an adaptive model, one which can be implemented gradually and without having to replace hardware. VITAL also makes use of current industry standards. It just rearranges them.

As mentioned in the last chapter, IBM's SAA has been moving away from the host-terminal model and toward a client-server model, which distributes both the applications and the processing down to the user level. VITAL expands on the client-server model by further distributing the functions of the server across a network. It also aims at making the client-server model neither host driven nor desktop driven. Instead, both hosts and clients are free to ask for and transfer data on their own initiative, through the use of automated functions that perform low-level linking between different computers.

The VITAL Model

VITAL specifies how information system applications should be designed to fit into this multiplatform, multinetwork, client-server model of IS computing. VITAL breaks up the traditional IS tasks into four types of application areas: data capture, data access, desktop integration, and repository. The four application areas are supported by an infrastructure of network and communications tools (see Figure 11.4). The separation of enterprise IS tasks into these areas is a key feature of VITAL. It eliminates bottlenecks in the system by dedicating machines to specific tasks; it modularizes software development along functional lines, making it easier to add different computers or change software features in one area without affecting the other; and since the user's desktop is just another module, it provides the user with a consistent interface. The modular approach also allows implementation over a period of time, minimizing disruption of the enterprise system.

Data Capture

VITAL specifies that the data capture environment is to be used only to create, update, or delete information from flat file or relational databases, not to search, analyze, and report. The data access component deals with retrieving and viewing information from different sources. The separation of these two functions into two distinct components of the system is done to optimize user efficiency. Usually, the people entering the data are not the same people accessing it, and the majority of users in an enterprise system are usually accessing data. With both data access and data capture functions in one application, users doing data access often tie up machines for users entering data. By using a client-server method of transaction processing, the data capture

users enter data on their terms. If the data access server is busy because too many people are accessing it, the data capture user is unaffected; the data capture server will continue to accept new input, but will wait until the data access server is free before sending the new data.

Figure 11.4

VITAL breaks up enterprise computing into four areas, all supported by a network infrastructure of hardware and software.

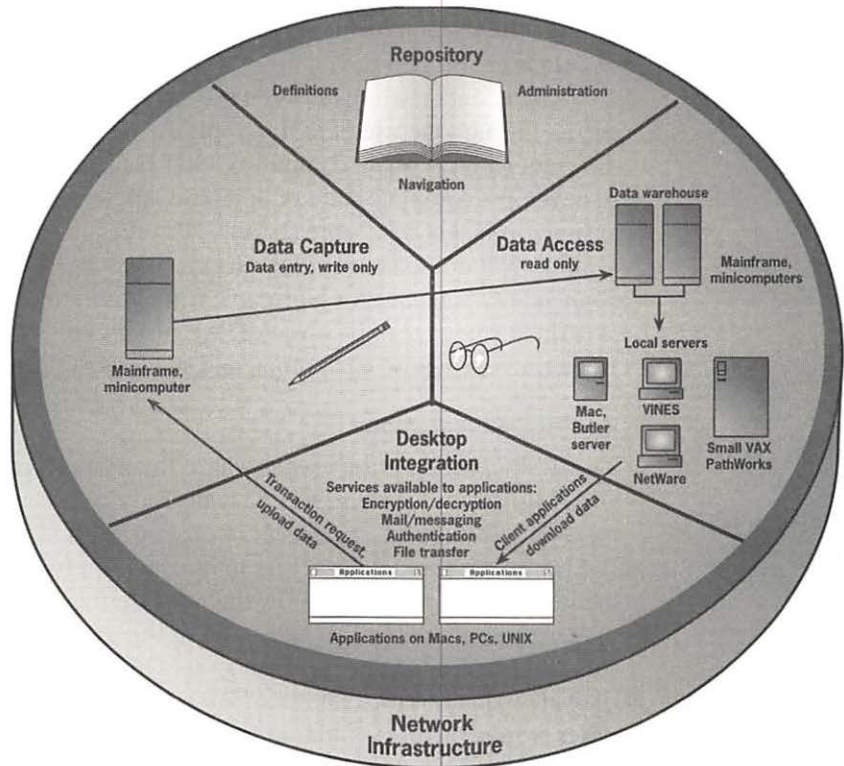

Data Access

Within the data access environment, the storage of data is further divided into a database warehouse, a network of bigger mainframes, and local servers, which service workgroup-sized departments and organizations within a company. Local servers can be smaller Digital VAXes running PathWorks, UNIX workstations running NFS, PCs running Novell NetWare or Banyan VINES, or Macs. Users access only the local database servers, not the data warehouse.

This information distribution scheme is similar to the way in which market products are distributed to consumers. Within IS, information is the product and the user is a consumer. The best way for a consumer to obtain goods

is to go to a retail store, which is a local server in VITAL. If consumers went directly to the warehouse, they would have to decipher obscure stocking codes to locate the goods. In addition, different warehouses (different brands of mainframes running different database applications) use different codes and naming procedures. Under VITAL, users can go to one of many retail outlets (local servers), where they can find products (data) from different warehouses neatly stacked on shelves, arranged in user-friendly aisles. This reduces the burden on all the servers and makes management and tracking of data more effective.

All the data sharing between servers and between servers and users occurs through the use of SQL. Apple's DAL can be used as a single API for different databases and computers and Mac and PC clients. Apple has plans to develop a complete suite of database Apple events so that applications can automatically get data from servers. However, though VITAL offers DAL as a solution, it doesn't require it. An organization could use other APIs, a PC connectivity language, or Norman's Totally Awesome Data Access Language, or write a language of its own. VITAL just specifies that you use shared databases that can talk to each other, and suggests SQL, the industry standard.

Desktop Integration

The desktop integration area is where the user interacts with the enterprise-wide information system. VITAL calls for a consistent user interface for *all* types of information, regardless of the source. It also uses the philosophy of DAL: Users should have access to information from any location without having to know where and how the information is stored. Just as AppleShare makes local file servers an extension of the desktop, users under VITAL should experience the enterprise system as an extension of the normal way they view the desktop, whether they're using the Finder or Windows. In other words, the user is spared from viewing the complexity of the enterprise system. This is a tall order to completely fill, but Apple has begun to provide the needed technology with its focus on system software extensions.

Desktop integration is achieved through the creation of integration services, which can reside on each personal computer or on a workgroup server. *Integration services* are software modules from Apple and others that communicate with different networks and mainframes, and can handle multiple user IDs for different servers and networks and applications. Instead of having each application deal with these things individually, the applications access the services, which take care of the dirty work of interfacing with the network. The global directory servers offered with VINES, AlisaMail, and other products mentioned early in this book are one type of integration service. Another service called data synchronization will make sure that copies

of databases on individual computers are current with the latest official copy on the server.

VITAL defines several dozen services; the more that are implemented, the easier it is for the user. How the services are implemented is up to the designer. One implementation of many of the integration services is Apple's Open Collaboration Environment (OCE), which will be described in more detail in Chapter 14. OCE will supply directory services, which will enable users to easily locate network facilities and users with a directory icon on the desktop. Other OCE services will include mail, messaging, encryption, and authentication. All OCE services will be available to any application through a standard API. As a new, easy-to-implement System 7 feature, it is highly likely that most developers of off-the-shelf Mac software will implement OCE.

Under the VITAL model, the Macintosh is the easiest platform to use as the user workstation—after all, the bottom-line purpose of VITAL is to sell more Macs. However, since VITAL is a multiplatform model—any Mac-only enterprise solution would be pure fantasy—Apple has committed to porting at least some of OCE to other environments. With Apple already selling scanners and printers in the Windows market, a Microsoft Windows OCE is the first likely target.

Repository

VITAL separates *metadata*—data about data—from the databases of corporate information. The repository can reside on multiple machines, on warehouse and local servers, even on Macs. But the repository must be a separate function from the individual databases that store information such as customers' names and product information.

The repository contains shared data definitions, such as catalogs of the databases in the enterprise system. It also contains data dictionaries, which do such tasks as define the terms used in different databases. It would, for instance, inform the system that a field called "CUST_NO" in an ORACLE database on a VAX is the same as "Customer Name" in a 4th Dimension database on a Mac. In a VITAL system, the user wouldn't have to learn the mainframe terminology, because the software would know to consult the repository for these data definitions. The repository provides users with common definitions.

Another example of metadata kept in the repository is extract specs, which tell an application how often to automatically access data from a database. Financial data may need to be accessed every 15 minutes, and customers' payment records may need to be accessed only monthly. Authorization data—who has access to what and for how long—is also a type of metadata. Authorization data makes sure that all database updates are valid and come from authorized sources.

The repository also keeps a directory of directories, to help users find information on the network. This could include directories of servers and the services and data they offer, as well as network configurations, and hardware and software configurations.

Systems Infrastructure

The infrastructure is the multiplatform network, consisting of local and wide-area networks, the various protocols that run on them, and the gateways and devices that are needed for interconnectivity. Also included are network operating systems and file, print, and mail server software. Basically, everything discussed in Chapters 5 through 10 would fall into VITAL's systems infrastructure. VITAL recommends that servers be distributed throughout physical locations, but that access to them is not limited by location.

VITAL Plans

Apple provides technical VITAL specifications to its corporate customers. These include a series of booklets and more detailed design guidelines. For each of the areas defined by VITAL, Apple has a decision matrix to help a system developer choose from dozens of design templates.

Each template includes high-level flow charts that provide a set of processing techniques for designing a specific part of the VITAL model. They show the interaction between desktop and mainframe systems, but are not specific to any hardware or software solution. Templates help an IS group keep consistency among applications. Both the design templates and the decision matrices come with documentation describing details of the design and giving technical hints.

Design templates exist for almost every conceivable type of system. A decision matrix is a check-off list of the important facets of a system and their priority (see Figure 11.5). For instance, a data capture matrix asks you how important are things like data volatility, security risk, and posting priority (sequential or first-in-first-out). With the parameter prioritized, the matrix points you to one or more design templates.

Apple also supports VITAL with enterprise computing conferences for in-house developers. System integrators such as KPMG Peat Marwick are VITAL-trained to provide consulting services. Apple has also provided an 800 number for customers interested in obtaining information about VITAL: (800) 635-9550, extension 502.

Figure 11.5

A decision matrix is used to choose a VITAL design template for a piece of your particular management information system.

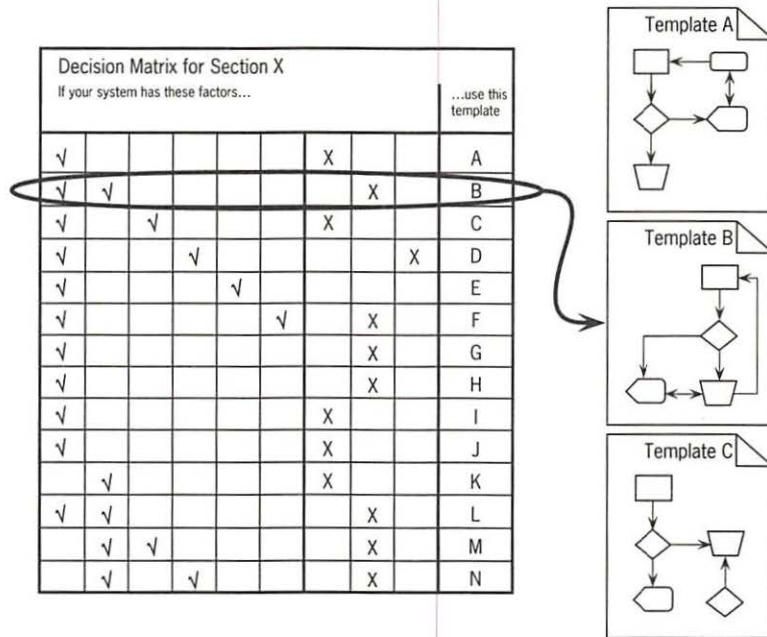

■ Looking Ahead

In this chapter, we've seen how Mac applications can connect to databases residing on other computers from desktop servers to mainframes. The Mac goes beyond simply being able to make the right connections; it can hide the complexity of networks and host databases from the user. This is a boon for many users, but in order for network managers to solve problems and maintain the flow of information, they need to see the complexity of a network, often in microscopic detail. In the next chapter, we'll take a look at the tools you need to take care of your infrastructure.

- *Helping Users over a Network*
 - *Using a Network to Manage Macs*
 - *Monitoring Networks*
 - *Poking at Packets: Protocol Analyzers*
-

CHAPTER

12

Network Management and Troubleshooting Tools

COMPUTER NETWORKS CAN'T ESCAPE THE EFFECTS OF entropy. As songwriter Paul Simon once phrased the second law of thermodynamics: Everything put together sooner or later falls apart. That includes AppleTalk networks. A misbehaving router can cause problems as hard to track down as an electrical fault in a car. File servers and printers can disappear from users' Chooser lists—with or without the help of a bad router. And traffic can bring network communications to an exasperating crawl. A growing network also means more users with growing needs. For instance, for a system administrator, installing the latest version of system software on a hundred Macs can become a full-time job in

itself, leaving little or no time to help users with software or hardware problems.

The pains of network change are usually felt most by the support staff found in many organizations. If your company doesn't have a support group—and you're the one who has assumed responsibility for setting up the network because you like computers—then these problems may be your problems. This chapter is for present and future support personnel: network managers, in-house tech support and training staff, and anyone who helps users with their Macs. As a network manager, you have a large choice of tools that greatly reduce the running around, the guesswork, and the confusion. However, shopping for network management tools can be confusing in itself. There are a lot of products with overlapping features and functionality. Some of these features are useful, some of them are not, but all of them are called network management tools, regardless of what they actually do. This chapter organizes the tools for support staff into functional categories. I've listed them in order of increasing complexity, with the simplest at the beginning, and those requiring the highest level of technical knowledge toward the end.

In addition to software that helps a network manager with the care and feeding of the network, there is also a class of programs sometimes called network management software, even though they don't actually help you to manage a network. Nevertheless, these programs allow you to accomplish some very useful tasks that help users and can save hours or even weeks. For example, these include tools that can inventory the hardware and software on Macs connected to a network, and tools that let you update users' software over a network.

Of the tools that actually help you manage a network, there are three basic types. All three are useful in performing preventative maintenance and in troubleshooting problems. *Traffic monitoring tools* let you know if your network design—the placement of the routers, services, and users—is able to keep up with user demand. *Device monitoring software* keeps you up-to-date on the status of network devices; some of these programs even have the ability to call you on your beeper if a device goes down. The third type is useful when you know something is wrong but you don't know why. *Packet analyzers* (also known as *frame capture tools*, though I like *packet pokers*) are troubleshooting packages that let you look inside the packets going across the network. Unlike traffic monitoring tools, which simply count all packets, packet pokers can list packets by type.

To give you a better idea of what you're looking at, I'll give you a closer look at the protocols that make up AppleTalk and discuss how they relate to other network protocols. Recently, AppleTalk networks began using a new protocol, the simple network management protocol (SNMP), a standard borrowed from TCP/IP. When SNMP is added to both network devices and

network management tools, network managers are armed with additional sets of statistics that can be used to troubleshoot or fine-tune a network.

■ **Helping Users over a Network**

There are many tasks that a manager of a network, computer facilities, or a technical support group can accomplish with a network. In fact, if user services such as printing, database access, and electronic mail aren't reason enough for putting every Mac at your location on a network, the network tools that enable you to manage Macs certainly are.

All of the tools discussed below are applications that run on a Mac and perform their functions over a network. I'll start with automatic backup of users' Macs and how to provide technical support over a network. Following that is a discussion on taking inventory of the hardware and software in users' Macs. I'll finish up with the latest entry in this category, programs that upgrade users' software over a network.

Although the packages discussed below perform a variety of functions, these applications have some characteristics in common. They require putting a file or two in each user's System Folder. They can help understaffed support groups save hundreds of hours while providing better service to users. And they're all easy to use and do not require a high degree of technical knowledge, freeing up the hard-core techies for other tasks.

Backing Up over a Network

In previous chapters, I've mentioned several network operating systems on PCs, minicomputers, and mainframes that perform automatic backup, such as Novell NetWare and Digital's PathWorks. Fortunately, you don't need the expense or complexity of one of these systems to get automatic backup of users' hard disks. Several Mac-based backup programs will automatically back up users' hard disks to a central Mac. This central Mac could be a dedicated machine set up as a backup server, or a machine running AppleShare or another network service.

Some of these programs are sold alone, such as SnapBack from Golden Triangle and Retrospect Remote from Dantz Development, and others are bundled with tape drives. Most network backup programs will let you back up to a hard disk or tape, but you'd better make sure you have plenty of storage space for the purpose. If you are running the program on a file server Mac, you might want to invest in a hard drive that can hold a gigabyte or two. The most economical storage medium for mass backup is digital audio tape (DAT); some DAT drives are available that can store up to 8 gigabytes on a single tape.

Setting up a network backup program is a little like setting up a file or mail server. You enter the name of the users and groups to be backed up and set the time, day, and frequency of backup. Backing up moves an awful lot of data over a network, so you'll want to set the backup procedure to start during off-peak hours, such as at night or on weekends. This means you'll have to remind users not to shut off their Macs before they go home. Leaving a Mac on all night doesn't mean you have to waste a lot of energy; users should be encouraged to switch off their monitors before they leave. Monitors eat more power and usually produce more heat than CPU boxes. Shutting off a monitor while keeping a Mac on won't hurt the Mac or affect any running software.

Because of the speed limitations on the network, you may find the backup procedure still running in the morning when the staff returns to work. This is not desirable, since during office hours, you'll probably want to reserve network bandwidth for normal network activities. It's hard to predict how long a series of backups will take, so you may have to conduct a few trial runs. Keep in mind that network backup is much slower on LocalTalk networks than on Ethernet or token ring networks, and that communications between the backup server and the Mac being backed up will also slow down for each router hop that the data needs to travel.

If you don't have enough time to back up everything on the users' disks every night, you'll have to be selective about who, what, and when you back up. First, set your software to back up only files that have changed. After every user is fully backed up once, subsequent backups will occur in a fraction of the time. Also, it is usually not necessary to back up applications, since most users should have the original program floppy disks. You can also schedule users to be backed up in a staggered fashion, such as every second or third night. Additionally, you might opt to have two or more Macs running backup software in different networks, thus multiplying the backup effort and avoiding router jumps.

Of course, all this assumes that backup and restoration of files is set by the network administrator, as it is with Retrospect Remote. SnapBack takes a different approach, letting the users choose what to back up and restore and when to schedule automatic backups (see Figure 12.1). The administrator is needed only to set up the backup server and users. This frees up the administrator for wrestling with routers and enables users to instantly have access to a file they may have accidentally deleted. However, the administrator relinquishes control of how much data is backed up and when the backup will occur, so that there is the chance that multiple users will choose to back up at the same time during a period when other users are affected by the increased traffic. Because the lack of central control becomes more of a

problem as the number of users grows, a program such as SnapBack works best in workgroup-sized clusters of users.

Figure 12.1

A backup server such as Golden Triangle's SnapBack can save a network manager's time by enabling users to schedule backups to a central location on the network.

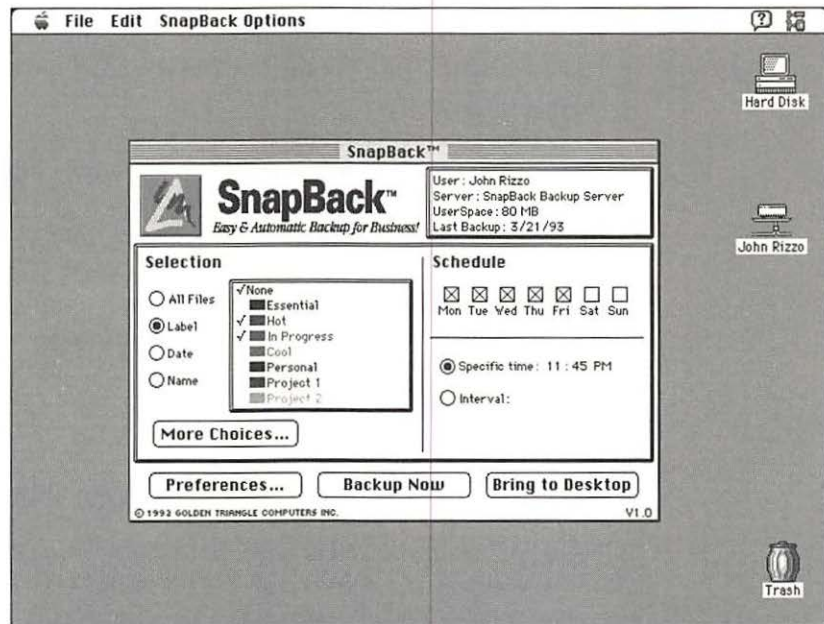

A user-based backup server is only helpful to a network administrator if it is easy enough for the user to set up. If you end up scheduling backups on each individual Mac because the users don't want to take the time to learn a complex program, you might as well use a backup program operated by the network manager. The SnapBack client software is easy to use, sporting a simple, uncluttered interface. It presents few options, and stores files in native Macintosh hierarchical file system (HFS) format. Retrospect Remote stores files in its own proprietary format, offering encryption and compression—a definite value, but the complex interface makes you glad it isn't user initiated.

Providing Training and Tech Support

People who staff the help desk within a company often have the job of helping users with software problems. The problem may be technical in nature, such as a software conflict, or may be due to a user's inexperience with the software. In either case, it's often difficult to pinpoint the cause of a problem

over the telephone. Often a user will give a general description of what is happening, such as “When I click on the square thing, my computer stops.”

One type of application that can help in cases like these is a program that enables you to control a Mac or a PC via a network—from your Mac. As discussed in Chapter 4, Farallon’s Timbuktu and Microcom’s Carbon Copy Mac are screen-sharing programs that allow you to control another Mac on the network or over a phone line. The screen of the remote Mac appears in a window on your Mac.

Screen-sharing programs can be put to good use as tech support aids. Using one of these programs, a user on the network can show you what he or she is doing and reproduce problems on your Mac screen. Since you can also control the user’s screen from the window on your Mac, you can show the user what he or she is doing wrong. You can also employ screen-sharing programs to teach a group of users how to use software. To do this, you can set screen-sharing software on your Mac to enable users to sign on to your Mac as observers, so they can only see your Mac, not control it. With the aid of a conference call on the telephone, you can teach a class while sitting at your desk.

■ Using a Network to Manage Macs

In small to medium-sized organizations, the person or group responsible for the network is often also responsible for setting up the Macs and keeping them running. Larger organizations assign these duties to separate groups. Even if you don’t have responsibility for the network itself, there is no reason not to use the network to help you take care of the Macs under your charge.

Two major functions that have traditionally been done by hand can now, for the most part, be handled by network software. The first is asset management, a procedure that generates lists of the software and hardware installed on every Mac. The second is the installation of software over the network. The two functions work well together: It’s useful to see what’s installed on a Mac before you upgrade its software. You can buy both functions in one program, or buy a separate package for each task.

These programs can’t do everything for you, but they do automate a great deal of the procedures and let you think in terms of groups of Macs instead of individual machines. Using them can reduce the time it takes to complete a software and hardware inventory or update from months or weeks to days or hours. However, it’s important not to lose sight of the fact that Macs exist to serve the users in their work, not the other way around.

Taking Inventory over a Network

Using asset management software can be an enormous time saver when you need to know what software and hardware is installed on Macs. For instance, a major group upgrade, such as converting all users to System 7 or upgrading from LocalTalk to Ethernet, requires that certain files, hard disk space, and RAM be on each user's Mac, and that other versions or incompatible files not be there. You may also need a list of hardware in every Mac, for instance, to help the accounting department to calculate capital depreciation. In any case, using software that gathers this information over a network is far easier than visiting every desk in the company, opening System Folders and Macs to record versions of extension files or the type of add-in boards and hard disks.

The exact types of information you can collect varies with each inventory package, but most programs can provide detailed configuration data, including the names and versions of applications, system software, fonts, third-party system extensions and control panels, and even the settings of some of these. For instance, if you need to determine how well people are making use of the advanced features of System 7, you could tell which users had 32-bit addressing and virtual memory turned on. You can also collect information about hardware, including the Mac model, the amount of RAM, the types of hard disks and monitors, as well as the types of NuBus cards, the vendor that built the hardware, and sometimes even the serial numbers (see Figure 12.2). Some of the programs also provide information on printers, including the resident fonts, RAM, and hard disk configurations, and let you change the names of printers.

In order for the inventory programs to access this information, you have to drop a responder system extension into the System Folders of the networked Macs. These are often accompanied by control panel files that users can employ to limit access by the network administrator. Responder files are also used by the software updating packages and some of the traffic monitoring packages described later in this chapter. Unfortunately, each program requires its own responder extension, so if you use more than one brand of network information gathering software, users will need multiple responder files.

Once the responder files are installed, you do the rest from your Mac. The first step that you take with most asset managers is to search the network to assemble a list of devices on-line. You can then select the devices that you want to scan, and sit back while the inventory application makes a connection to each user and reads the information. You can sometimes filter the specific information in which you are interested, reducing the time of the scan. The scan can take anywhere from a few seconds to a few minutes per machine, depending on the amount of information you've requested, the speed of your software, and the network traffic conditions. Some of the programs allow you to schedule unattended scans for times of light network traffic.

Figure 12.2

Inventory management software such as GraceLAN can collect detailed information on the hardware and software in the Macs on a network.

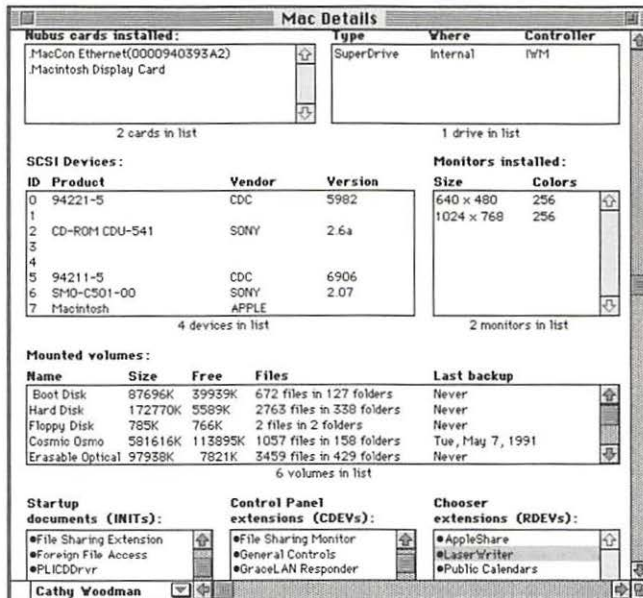

The resulting list of information is sometimes referred to as a profile. Several of the programs also allow you to send messages to users at any time, or to send a message automatically before or after a profile has been collected. The information in a profile can be saved if the inventory software has a database, which usually lets you enter your own information and notes about each machine. You can also export the profile data to a spreadsheet or to your own database. A database is very convenient for sorting through the piles of data you collect, enabling you to create reports of specific data fields. For instance, if you were looking for a system extension that was conflicting with a piece of software, you could create a report containing data from the users experiencing the problems and look for an extension file and version. Many of the packages come with or offer an option for a single-user version with which a user can profile his or her own Mac.

A Look at Inventory Products

There are about a half dozen good asset management packages available, differing slightly in features and their approach to collecting information. Most are mature products past their 2.0 and 3.0 releases. Since it's a competitive field, most of the developers frequently add new features.

The first, and still one of the best, of these packages is Status•Mac, originally developed by Pharos Technology and now marketed by On Technology.

Status•Mac features the convenience of store-and-forward profiles—if a Mac is turned off, a profile request will be sent automatically to that Mac the next time the Mac is turned on. This feature, together with the ability to set regularly scheduled profiles automatically, enables you to keep current Status•Mac's built-in database. Status•Mac's database is well organized and a good performer. Status•Mac comes with almost 100 profile templates to gather and display specific sets of information (see Figure 12.3). For instance, a System 7 template gathers information on the prerequisite setup for upgrading from System 6. You can also create your own templates by choosing fields from the database.

Figure 12.3

Reports can help you sift through a database of collected profiles. Status•Mac comes with several dozen pre-defined templates.

The screenshot shows a window titled 'STATUS' with a menu bar (File, Edit, Report, Profile, Archive, Window, W/F+). Below the menu bar is a title bar for the report: 'All Applications by User'. The report text reads: 'This report lists all applications present on any profiled volumes. Useful for checking compliance with licensing restrictions and for identifying users who need upgrades to new software versions. NOTE: In almost all cases, it is more reliable to identify applications by Creator. This is because the application name can easily be changed by the user.'

#	Profile Name (Prof Mgmt)	Application Name (App)	Creator (App)	Version (App)	Volume Name (App)
1	Amble, Joan	Microsoft Word	MSWD	4.0	Ambler 40
2	Bertha Garcia	Microsoft Word	MSWD	4.0	Pumpkin
3	Bronowski, Jacob	Microsoft Word 4.0	MSWD	4.0	Pythagoras
4	Carlos Fuentes	Microsoft Word 4.0A	MSWD	4.0	CMC
5	Joe MacDougald	Microsoft Word	MSWD	5.0	Hard Disk
6	Joan Metzger	Microsoft Word	MSWD	5.0	Thor Jr.
7	Kelly Martin	Microsoft Word 5.0	MSWD	4.0	The Real Thing
8	Kim Agricola	Microsoft Word	MSWD	5.0	Ursa
9	Loz Rosley	Microsoft Word	MSWD	5.0	My hard disk
10	Network Manager	Microsoft Word 3.0	MSWD	5.0	Bart
11	Rosemary Nolan	Microsoft Word	MSWD	4.0	Macintosh HD
12	Schwartz, Rhonda	Microsoft Word 4.0	MSWD	4.0	Schwartz 80
13	Scott Cole	MS Word™ 4.0	MSWD	4.0	Macintosh HD
14	Skillman, L.	Microsoft Word 3.0	MSWD	5.0	Bucket O'data

The window also shows a 'Hard Disk' icon on the right and a 'Trash' icon at the bottom right.

Another excellent program is GraceLAN Network Manager from TechWorks. Like Status•Mac, GraceLAN can see printers, but can also see routers and PCs. One command runs test packets from your Mac to another, and reports the average response time and error count needed to check the physical connections. From PCs, GraceLAN can read such things as the version of DOS, the amount of memory, and the number of hard drives. DOS users have to install a TSR (terminate and stay resident) program, the equivalent of a Mac system extension. However, because the PC hardware and operating

system aren't as tightly integrated as the Mac is, inventory programs cannot provide information about PCs in as much detail as that gathered from Macs.

GraceLAN doesn't have a built-in database manager, but takes a modular approach with an add-on database called GraceLAN Asset Manager. Asset Manager is geared toward every aspect of computer inventory management, so in addition to fields for holding information collected with GraceLAN Network Manager, this database contains dozens of other fields in which you can enter data by hand. These include fields for tracking costs and payments for equipment, as well as fields for holding contact information.

Network SuperVisor from CSG Technologies features a strong integrated database with good querying and navigation tools. With it, you can create lists of standard hardware and software setups for your users, and then send scans out to Macs to check for compliance. CSG also offers the 4D Developers kit with which you can tailor Network SuperVisor to your own asset management needs using Acius's 4th Dimension. Network SuperVisor, like GraceLAN Asset Manager, is based on 4th Dimension, although 4D is not required to run either program.

Network SuperVisor also includes some of the alarm features of the network monitoring software discussed later on. For instance, you can set alerts to notify you when network devices or services disappear from the network. You can customize the Alert tool to respond to specific events. A log will record these types of network events when they occur.

There are secondary features found in some of these packages that are sometimes included in some network monitoring software as well. GraceLAN, Network SuperVisor, and Radar from Sonic Systems have a feature called *topological mapping* that produces a logical map displaying nodes on the network (see Figure 12.4). Radar also has alarms that will notify you when any of the nodes in the map go down. Farallon also makes a stand-alone mapping program, NetAtlas. These maps are useful for giving you a visual picture of what types of machines are on the network and who is using them. Network SuperVisor takes this a step further by adding a basic drawing environment, which you can use to draw a rudimentary floor plan as a record of the physical location of the network's nodes. Since nodes that go off-line are represented by a dimmed icon, displaying them in the context of a floor plan can help you find them. You can also purchase the topology editor as a separate product, Network SuperVisor TE, which can link to paging services through Ex Machina's Notify! for status alerts.

Watch out for programs that can only check a Mac's start-up disk—reviewers of these packages often overlook this very important limitation. Although these programs give you information on the System Folder, you miss out on other disk drive information, as well as applications that may be stored on large external hard disks. Older versions of some of these

programs had this liability. Some asset managers, such as Radar, can see floppy disks as well.

Figure 12.4

Several programs, such as Network SuperVisor, can create a logical map of your network. Network SuperVisor adds a drawing environment so you can display the physical location of each device.

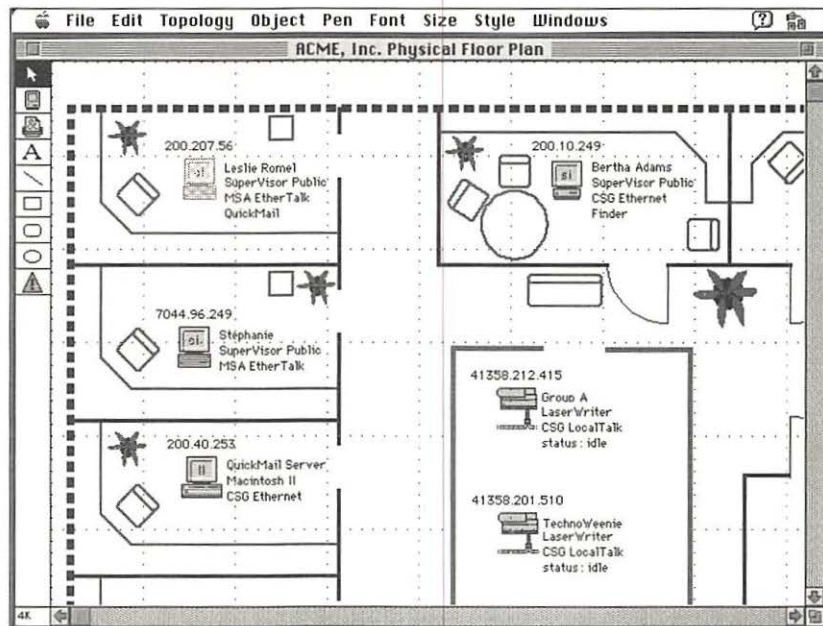

Radar from Sonic Systems has one of the best interfaces and does quick scans. Radar also has built-in monitoring and alarm functionality that will notify you when a Mac or printer goes down, or when a printer jams, runs out of paper, or is missing a paper tray. In fact, Radar has more printer control functions than any other similar program. Not only can you see the fonts in a printer's memory and hard disk, but you can move fonts between your Mac and the printer. You can also rename and restart a printer.

Installing Software over a Network

Software updating over a network is a quick and easy method of distributing new versions of basic connectivity files, such as e-mail drivers, AppleShare client software, and Communications Toolbox tools. Productivity applications, such as word processors and spreadsheets, can be more easily upgraded using a software updater application.

Most of the software updaters use the concept of an "upgrade package," a collection of software that can be sent to one or more users (see Figure 12.5). You create an upgrade package by selecting files that can be

totally unrelated, and by selecting a destination for each, such as the Control Panels folder within the System Folder. Some updating applications will also find the location of the file you are replacing and install the new version there.

Figure 12.5

Software update applications, such as NetDistributor, enable you to install groups of files on Macs over a network.

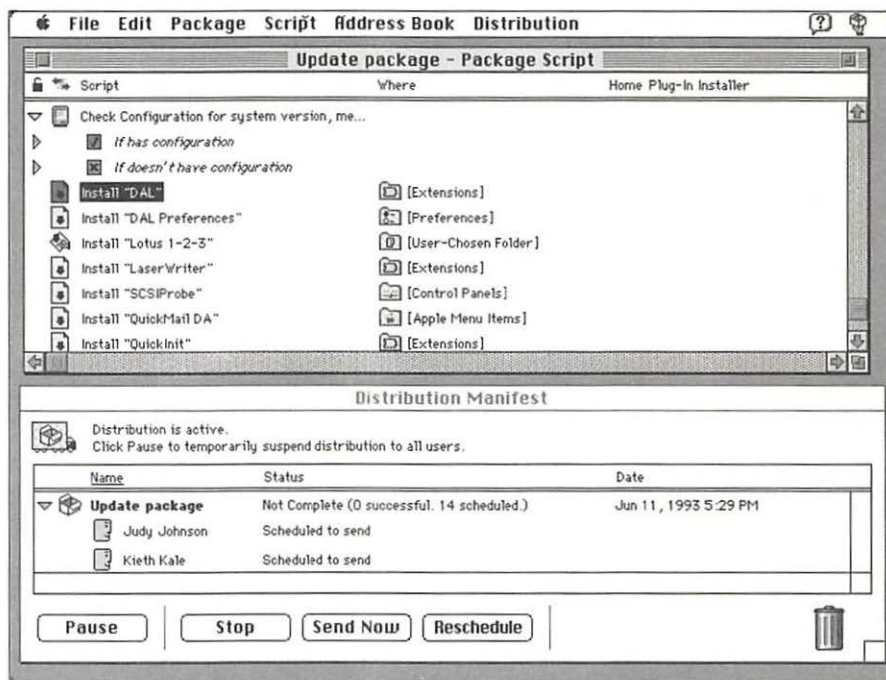

The upgrade package you create can be installed actively, when it is sent directly to users' Macs over the network, or passively, when you put the package on a file server and ask users to download it and run the package. This is not the same as merely making new software available on a file server: When a user double-clicks on the package file, all the software contained within it is installed in the correct places. Some programs have the ability to restart or shut down the Mac for extensions that need a reboot in order to work.

The Status•Mac and netOctopus inventory programs have built-in updating functions that are quite good. Like its profiles, Status•Mac's update packages use a store-and-forward design. The software updating function also appears in stand-alone packages, such as NetDistributor from Trik and GraceLAN Update Manager from Technology Works. Network SuperVisor has the ability to send a file to one or more users, but is not as powerful as the other programs. GraceLAN Update Manager gives the network administrator the option of deleting old files or moving the old files to a folder.

NetDistributer is one of the most aggressive updaters, allowing software to be deleted without user prenotification and allowing replacement of software that is currently in use. It can install fonts and desk accessories, even under System 6. NetDistributer also can import data from Status•Mac and GraceLAN Network Manager. NetDistributer has an icon-based scripting language that is used to place files on a user's disk. A script can look for a certain folder to install a file, and if that isn't found, take another action.

None of these programs as of yet can install software that requires using an installer program, such as Apple's Installer, but this capability is not far away. An installer program can decompress new software, replace old software with the newer version, and can even install resources in the System file itself. GraceLAN Update Manager has a feature called Install Watcher, which records the procedure an installer program uses, and gives you and the users text-based instructions. Radar has the ability to install various types of system software to individuals or groups.

Examining Rights: User's versus Network Manager's

Before you start deleting users' files for them, you should consider a rather controversial group of questions associated with both inventory management applications and software updaters: Should you use software that allows files to be read and deleted without the user's knowledge or permission? Should you be able to install and delete system software? Should network managers' tools have the ability to override users' security software, which keeps folders and files from all but the users' eyes?

The answers to these questions may determine what software you buy. For instance, Status•Mac cannot see document files at all, but Radar allows access to document files. The decision to include the ability to see documents is not a technological one, but a philosophical one. First, there is the question of violating some as yet undefined user right to privacy versus a company's rights to control its own property (the Macs, that is, not the users). Although it may be easy for the network manager to have complete control of users' computers, it's not always in the company's best interest to do this.

It's easy to see why some users would take issue with allowing someone to poke around their hard disks with asset management software. There are few arguments against allowing a network manager to see applications on a user's Mac, but data files are a different story. Many users' hard disks contain some sort of private data files—personal phone contact databases, résumés, or love letters, for instance. However, some users may keep information that is proprietary to the company, which a network manager has no right to see. Managers, who may keep files on employee performance and salaries, may not be happy about giving someone the ability to view these files.

Still, valid reasons exist for allowing the recognition and replacement of document files. For instance, during upgrades there is a need to recognize and replace preferences files, which are usually text files required by many applications. This issue needs to be seriously considered before purchasing and installing intrusive software.

A related issue is the degree of control the user has over inventory profiles and software updates. Regardless of the appropriateness of the network-manager-knows-best theory, the user may be in the middle of an important transaction, and can't afford to be slowed down by a scan of all of his or her hard disks. A user could also be working with highly unstable preproduction software that may not get along with certain profiler or software updater products. Installing system software without the user knowing it could be dangerous as well. If something goes wrong, the network manager may not realize it. And if the user doesn't know what happened, he or she could waste a lot of time trying to figure out what is going on with the system; not all users go running to their network managers when something fails.

When you look for inventory or updater software, it's not a bad idea to choose a package that gives the user some degree of control as well as notice of what actions are being taken. Remember, users could exercise the ultimate control choice, and delete the program's responder extension from their hard disks, denying you all access.

Status•Mac handles the issue of user control better than any other package. When a profile or update is about to be done, it asks permission of the user (see Figure 12.6). The user can click okay, to have the scan or update done immediately, or can choose to defer the action until a later time. This also gives the user time to prepare the Mac for a scan by mounting all volumes. If the user is not at his or her Mac, the profile is performed after an adjustable time period. Network SuperVIsor, Radar, and GraceLAN Network Manager and GraceLAN Update Manager let the user set levels of intrusiveness. With GraceLAN's control panel, a user can enable a network manager to see the name and machine type only, to see System info in addition, to see all info, or to make changes. GraceLAN Update Manager handles software updates in a manner similar to Status•Mac. When an upgrade package arrives, the user sees a message window that offers the choice to install or not to install. If the user chooses Don't Install, another window comes up offering times to reschedule the package.

■ Monitoring Networks

Among tools that help you manage the network itself, monitoring tools are a first line of defense against unexpected problems due to device failure or inefficient network design. There are two basic functions: monitoring the

amount of network traffic and monitoring the status of network devices in order to alert you to a device failure. These basic monitoring functions are usually represented by separate products, but features of each can be found in a variety of products.

Figure 12.6

Status•Mac enables users to delay a profile to a time when they are less busy or to a time when the Mac is better prepared.

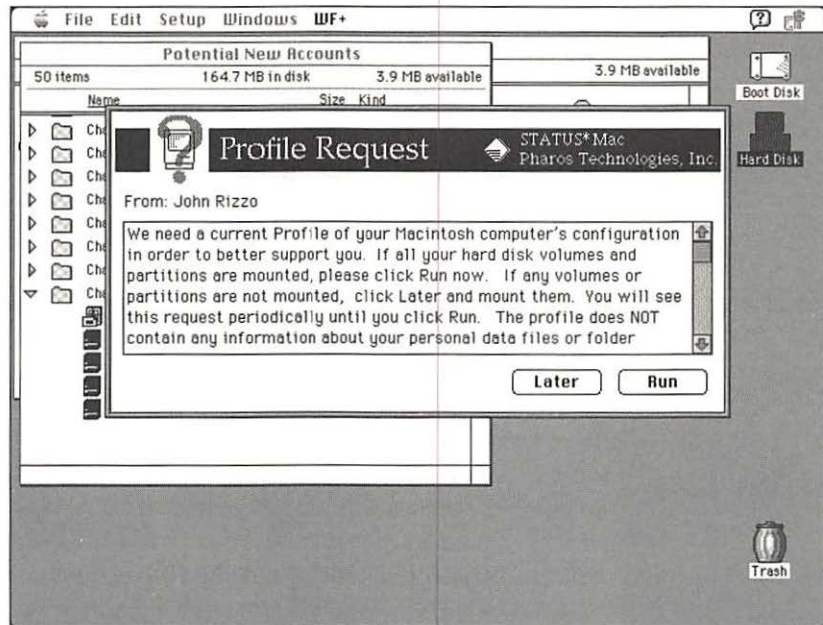

Recently, a new type of network management tool, the SNMP console, arrived on the AppleTalk monitoring scene. SNMP, short for the Simple Network Management Protocol, provides users with a common language to receive data and sometimes control network hardware from different manufacturers.

Monitoring Traffic

Traffic monitors measure and numerically or graphically display the number of packets going across a network. Traffic monitors can't see inside network packets, but can only count them. They can give you the number to and from each node or a total count.

Although network traffic will vary during the day, network traffic should stay relatively constant over the long term. Changes in levels of traffic on a network can mean that there is a signal problem. Levels of traffic that suddenly drop can indicate a problem such as a broken connection.

Rising network traffic can be an indication of data storms, the generation of unnecessary traffic for no reason, which can slow down network performance. Storms can be caused by packets with defective addresses that keep getting recirculated by devices, or by misinformed routers confused by another problem on the network. A malfunctioning network interface card could be *jabbering*, stuck in a state of transmitting continuous nonsense. Too much traffic on a single device may mean that the printers have not been spaced evenly throughout your offices, or that the location of file servers on the network needs to be adjusted. If you spot a lot of traffic going through a router, then the router, the users, or the services may not be in the most efficient location.

The majority of traffic monitoring programs not only displays a list of nodes on the network, but will also list *sockets*, processes running on the Mac that are visible to other network devices. (It's actually more correct to say that network processes run *in* sockets on the Mac—a socket is a type of network address within a node that enables data to be sent or received by a process—but I'll refer to sockets as the processes themselves for simplicity's sake.) Sockets include server or client software for mail or file services.

The simplest traffic monitoring product is Apple's Inter•Poll, one of the least expensive monitoring tools you can buy. Inter•Poll provides of list of nodes and sockets on one network segment (that is, between routers) and the number of packets being generated by each. It also gives you the total number of packets in real time. You can use Inter•Poll to send simple echo packets to a selected node to test the connection between you and that node.

Farallon's TrafficWatchII gives you a graph of the traffic to and from each node in real time (see Figure 12.7), and will report error rates. TrafficWatchII will also recognize and count non-AppleTalk packets such as DECnet, TCP/IP, and SPX/IPX (Novell NetWare), though not in as much detail as AppleTalk. TrafficWatchII can tell you the bandwidth utilization each protocol is taking up and plot the data in a pie chart. Both TrafficWatchII and Inter•Poll can only monitor one network segment at a time.

Dayna's NetScope Console is an application that retrieves and displays traffic information gathered by Dayna's NetScope Probe, a small hardware device that gathers information on network traffic. By locating a NetScope Probe on each network segment on an internet, NetScope Console can give you a view of traffic conditions around the entire internet. You can also get information on individual AppleTalk protocols (discussed later in this chapter), which can help you pinpoint problems. The NetScope Probe works on LocalTalk and Ethernet networks.

Figure 12.7

Traffic monitoring software such as TrafficWatchII can display a real-time graph of network traffic for each network device.

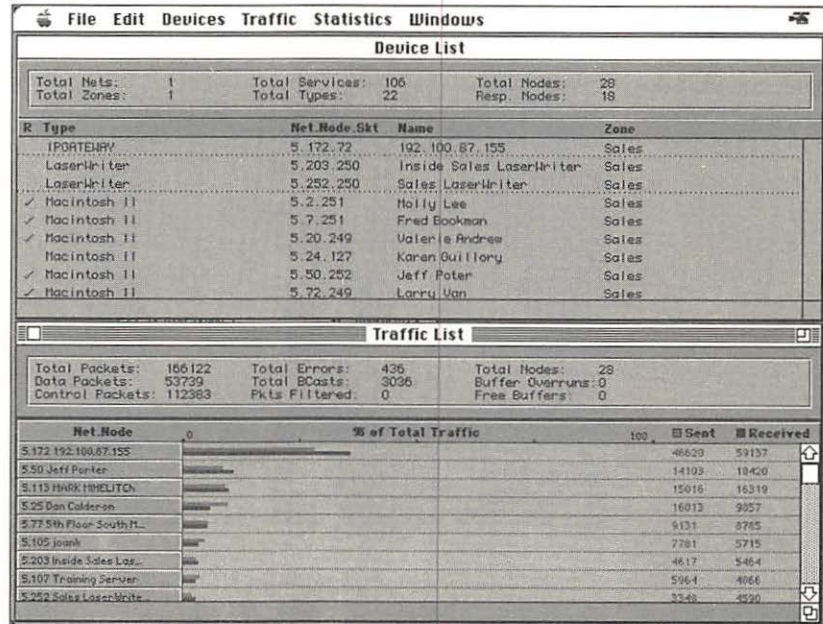

Monitoring Device Status

Status monitors keep an eye on every device in an internet and let you know if one has gone down. These programs can usually notify you of a dead router, crashed file server, or jammed printer by a screen message, an electronic mail message, or a sound recording; several monitoring programs can even call your pager and deliver a short text message such as “The marketing file server is down.” You can set the conditions about which you want the software to notify you. Status monitors can also play a sound or send an electronic mail message directly to Microsoft Mail or QuickMail client software.

Caravelle’s Mac-to-Mac NetWORKS was the first monitor program to send messages over a paging service. Mac-to-Mac NetWORKS has its own built-in dialing capability. In addition to pager and electronic mail notifications, Mac-to-Mac NetWORKS gives you an on-screen window to tell you whether devices are on-line (“up”) or off-line (“down”). This window displays a list of printers, Macs, and sockets, shown in the Device Type column in Figure 12.8. You can display all the sockets running in multiple zones, or just those you select to monitor, such as printers, file servers, or perhaps the users’ Macs in your production department. The on-screen indicator lights tell you whether a device is on-line or off-line.

Figure 12.8

Device monitoring software, such as Caravelle's Mac-to-Mac NetWORKS, can tell you when a file server or printer goes off-line.

The screenshot shows a window titled "Network B Status" with a toolbar containing icons for Add, Remove, Attach, Test All, Stop Test, and Get Info. Below the toolbar is a table with columns for Zone Name, Device Type, Device Name, and a status column with sub-columns for DN, OH, UP, and RT. The table lists 25 items, each with a corresponding status icon.

Zone Name	Device Type	Device Name	DN	OH	UP	RT
Marketing zone	Timbuktu Serial	5552156	<input type="checkbox"/>	<input type="checkbox"/>	<input type="checkbox"/>	<input type="checkbox"/>
Marketing zone	DayMaker	2FD516AB65	<input type="checkbox"/>	<input type="checkbox"/>	<input type="checkbox"/>	<input type="checkbox"/>
Marketing zone	A/LK	CAD-Mac	<input type="checkbox"/>	<input type="checkbox"/>	<input type="checkbox"/>	<input type="checkbox"/>
Production zone	AFPServer	Amanda's Mac	<input type="checkbox"/>	<input type="checkbox"/>	<input type="checkbox"/>	<input type="checkbox"/>
Production zone	Macintosh IIfx	Ben Temdale	<input type="checkbox"/>	<input type="checkbox"/>	<input type="checkbox"/>	<input type="checkbox"/>
Production zone	LaserWriter	Terry Sullivan	<input type="checkbox"/>	<input type="checkbox"/>	<input type="checkbox"/>	<input type="checkbox"/>
Marketing zone	LaserWriter	George Reinornate	<input type="checkbox"/>	<input type="checkbox"/>	<input type="checkbox"/>	<input type="checkbox"/>
Marketing zone	LaserWriter	IBM LaserPrinter	<input type="checkbox"/>	<input type="checkbox"/>	<input type="checkbox"/>	<input type="checkbox"/>
Marketing zone	Timbuktu Host	Marketing Server	<input type="checkbox"/>	<input type="checkbox"/>	<input type="checkbox"/>	<input type="checkbox"/>
Marketing zone	Macintosh IIfx	Marketing Server	<input type="checkbox"/>	<input type="checkbox"/>	<input type="checkbox"/>	<input type="checkbox"/>
Production zone	LaserWriter	Lucy Laser	<input type="checkbox"/>	<input type="checkbox"/>	<input type="checkbox"/>	<input type="checkbox"/>
Marketing zone	ComTalk™	Marketing ComTalk	<input type="checkbox"/>	<input type="checkbox"/>	<input type="checkbox"/>	<input type="checkbox"/>
Marketing zone	QuickMail	Marketing Mail Server	<input type="checkbox"/>	<input type="checkbox"/>	<input type="checkbox"/>	<input type="checkbox"/>
Marketing zone	Retrospect Remo...	Nancy	<input type="checkbox"/>	<input type="checkbox"/>	<input type="checkbox"/>	<input type="checkbox"/>
Marketing zone	Macintosh IIfx	The Boss's Mac	<input type="checkbox"/>	<input type="checkbox"/>	<input type="checkbox"/>	<input type="checkbox"/>
Marketing zone	PowerBook 170	The Boss's PowerBook	<input type="checkbox"/>	<input type="checkbox"/>	<input type="checkbox"/>	<input type="checkbox"/>
Marketing zone	AFPServer	Art Server	<input type="checkbox"/>	<input type="checkbox"/>	<input type="checkbox"/>	<input type="checkbox"/>
Production zone	Macintosh Quad...	Production Mac	<input type="checkbox"/>	<input type="checkbox"/>	<input type="checkbox"/>	<input type="checkbox"/>
Production zone	QuickMail	Production Mail Server	<input type="checkbox"/>	<input type="checkbox"/>	<input type="checkbox"/>	<input type="checkbox"/>
Production zone	Macintosh IIfx	Susan's Mac	<input type="checkbox"/>	<input type="checkbox"/>	<input type="checkbox"/>	<input type="checkbox"/>
Production zone	Macintosh II	Teresa's Mac	<input type="checkbox"/>	<input type="checkbox"/>	<input type="checkbox"/>	<input type="checkbox"/>
Marketing zone	Macintosh SE/30	Reception Mac	<input type="checkbox"/>	<input type="checkbox"/>	<input type="checkbox"/>	<input type="checkbox"/>

AG Group's Net Watchman is a similar product that can tell you when new nodes appear on the network and when zones disappear, a sure sign that something is amiss. Like Mac-to-Mac NetWORKS, AG Group's Net Watchman finds and records zones, nodes, and network services, using English names instead of node numbers. Net Watchman doesn't have its own built-in paging system, but uses System 7's Apple events to link to Ex Machina's Notify! paging software. Net Watchman can also warn you with an audible beep, a flashing icon on your screen, or a screen message.

Dayna's Network Vital Signs is another beeper-enabled device monitor (also linked to Ex Machina's Notify!), but it goes a step beyond Net Watchman to provide additional functionality (see Figure 12.9). In addition to notifying you when a network device goes off-line, Vital Signs will trigger alerts when a variety of other parameters go outside of limits you set. It does this by using modules that monitor classes of devices. For instance, a module is included that monitors Shiva's FastPath routers; it can trigger an alert if performance deteriorates or traffic increases. An Apple LaserWriter module can tell you when the printer is out of paper, and an AppleShare module can tell you when you're running low on disk space. A module can also monitor the NetScope Probe, and will notify you when network traffic levels that you have set are exceeded.

Figure 12.9

Dayna's Vital Signs provides device-specific monitoring that will notify you about a variety of factors, not just whether a device is on-line or not.

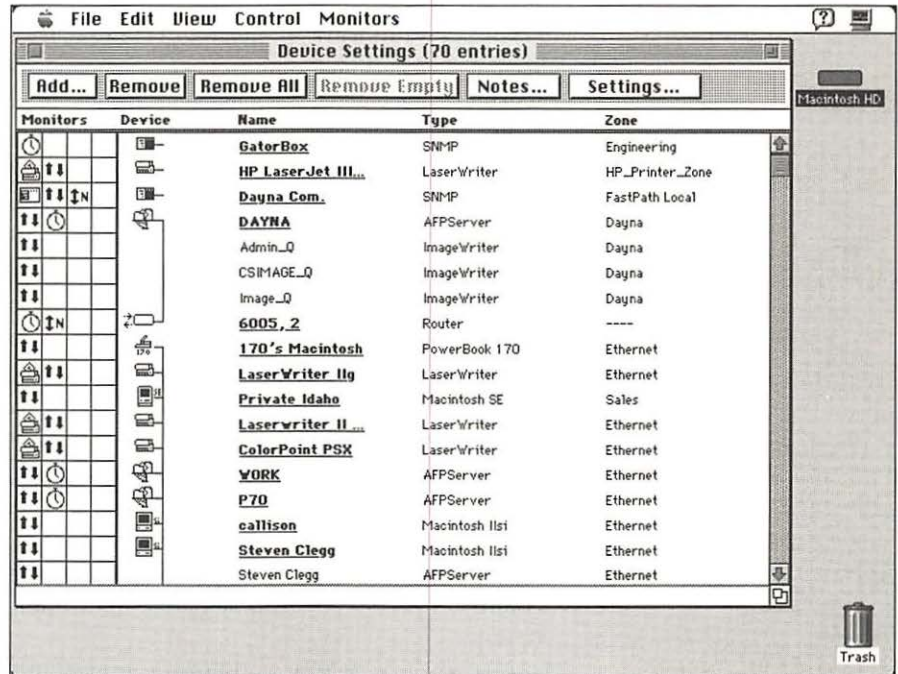

Monitoring with SNMP

A significant enhancement to network monitoring on AppleTalk was introduced in mid-1992, when Apple enabled the use of the Simple Network Management Protocol (SNMP) for monitoring AppleTalk devices. SNMP is meant to act as a common language that can be used by network management software to communicate with routers, printers, and file servers of all brands. Before SNMP, each AppleTalk router manufacturer had its own proprietary communications language to manage its line of routers. If there was a problem with an AppleTalk network that involved resetting routers, every router had to be reset individually. Using SNMP-compatible software, SNMP-compatible routers can be reset all at once from a Mac. SNMP can also be used to monitor and control printers and to read and set users and groups in a standard manner over the network. It is even possible to control NuBus cards over a network with SNMP-compatible software.

SNMP is a de facto industry standard that comes from TCP/IP. Apple abandoned an effort to invent its own feature-filled network management protocol, the AppleTalk Management Protocol, in favor of the less powerful but widely used SNMP. Apple's decision to adopt an industry standard

management protocol was a sound one, since the complexity of networks is growing, with protocols of all types of networks running over the same wire. SNMP is designed to work on networks running mixed protocols.

SNMP network management software, called SNMP consoles, gathers information from network devices by reading a *management information base (MIB)*, a network-wide distributed base of data stored on individual nodes. AppleTalk became SNMP-aware when Apple defined an MIB for AppleTalk, which was published through the Internet Engineering Task Force, an industry standards group. It is now up to the hardware manufacturers to implement the AppleTalk MIB in their network devices.

SNMP Hardware

The first group of AppleTalk hardware devices to support SNMP were routers and hubs. Manufacturers sometimes call these SNMP-enabled devices *smart hubs and routers*, because they can collect statistics on performance, errors, and traffic. The reason SNMP routers were developed first is because Apple's first-round MIB supported the lower-level AppleTalk protocols used by routers. (AppleTalk protocols are described later in the chapter.) Printers and AppleShare file servers use higher-level protocols, which were more recently added to the AppleTalk MIB, again through the Internet Engineering Task Force.

The first AppleTalk MIB definition was also limited by the lack of ability to make changes to network devices. Hardware manufacturers can get around this by writing extensions to the AppleTalk MIB that can add these capabilities. The first SNMP-compatible routers carried MIB extensions to enable them to be reset. Device vendors can also create their own private MIBs to implement special control features in their own SNMP console software. Although SNMP software can support various private MIBs, many network products running on Macs still require a separate responder file for each vendor brand, as with the asset management software described earlier. When MIBs finally become standardized, there will most likely be a universal responder file for Macs, or it will be built into the system software.

SNMP Software

One of the first SNMP consoles was RouterCheck 2.0 from Neon Software. RouterCheck is a device monitoring and fault-notification program similar to those mentioned above, but it can collect additional statistical information using SNMP.

RouterCheck is designed for monitoring routers, repeaters, bridges, and gateways, but does not see printers or network services (see Figure 12.10). This is not really a deficiency—a plumbing-specific monitoring package like RouterCheck makes sense for organizations in which the support group that

manages routers and the internet is not the same group that manages Mac workstations, printers, and file servers. RouterCheck is designed to recognize specific brands of routers, including Cayman, Shiva, Novell, Apple, Cisco, and Ungermann-Bass.

Figure 12.10

RouterCheck can use SNMP to monitor, control, and collect statistics from routers of different brands.

The screenshot shows the RouterCheck application window. The main window has a menu bar (File, Edit, Check, Report, Windows) and a title bar (Router List). Below the menu bar, there are two dropdown menus: "6 router ports sorted by: Net" and "View: current routers". A table lists the routers:

Net	Node	Zone	Type	Name
11	5	Sales & Marketing		Fred the Router
20	149	Engineering		Leon FP2 (2B2B)
30	22	Art Department		
45	42	Twilight Zone		
100	13	Daybreak Zone		

Below the table are buttons for "Query", "Stats", and "SNMP". A "Router Polling" section shows "Number of router ports polled" and "Polling status: Paused...". At the bottom, there are "Start" and "Options" buttons, and a status bar showing "Last poll: 00:05:00" and "Poll rate: 00:05:00".

An "SNMP Data" window is open over the table, showing "DDP Counters" for the selected router "Leon FP4". The data is as follows:

Packet Transmission Requests:	1220838
Short DDP Packets Transmitted:	170025
Long DDP Packets Transmitted:	1049066
Packets Received:	4469603
Packets Asked To Be Routed:	868329
Packets Addressed To Router:	3601276
Packets With No Handler:	0
Packets That Couldn't Be Routed:	1749
Packets With Length Too Short:	0
Packets With Length Too Long:	0
Broadcast Packets Dropped:	0
Short DDP Packets Not Routed:	0
Packets With Excessive Hop Count:	0
Packets With Bad Checksums:	0

Like some of the other device monitoring packages mentioned above, RouterCheck works with the Ex Machina's Notify! pager notification system to alert you to a problem with a router. Not only does RouterCheck notify you if a router goes down, it can tell you when a router deviates from normal performance by a percentage that you can set. You can also use RouterCheck to see how each router port is configured. RouterCheck will display routing and zone table information, which is helpful for troubleshooting problems. For instance, if you suspect that a router needed to be reset, you could figure out which router by comparing the routing table information of nearby routers.

■ Poking at Packets: Protocol Analyzers

The protocol analyzer is the tool in the network manager's toolbox that is used for the lowest-level digging into the guts of network traffic. Protocol analyzers for AppleTalk networks are often software applications that can count, read, and interpret data packets as they pass by on the network. The data can be viewed in real time or saved for later analysis. Either way, the microscopic view of the network that protocol analyzers provide can often be the key to solving your most baffling network mysteries.

Protocol analyzers are available as hardware or software products. The software protocol analyzers run on a Mac give you about 95 percent of the functionality for about 20 percent of the cost of the hardware analyzers, and are much easier to use. You don't give up much by using software analyzers—they're even effective for troubleshooting non-AppleTalk networks. Some organizations use both types of protocol analyzers, the software for most of the time and the hardware for those occasional bafflers that require that extra 5 percent.

Using a protocol analyzer effectively requires a more detailed knowledge of AppleTalk protocols than do the tools mentioned so far. So before beginning the discussion of protocol analyzer tools themselves, here's a look at the protocols that make up the AppleTalk network.

Perusing Protocols

Although AppleTalk is often spoken of as a network protocol, it is actually made up of a set of protocols that perform a variety of functions for network communications. I've already discussed one, the AppleTalk Filing Protocol (AFP), in previous chapters. I'll introduce some of the other protocols that Macs and other network devices use on AppleTalk networks. The following is meant only as an overview of the protocols that make up AppleTalk, to give you an idea of what to look for when troubleshooting AppleTalk networks. For a detailed description of the AppleTalk protocols, I recommend Apple's official book on the subject, the well-written *Inside AppleTalk*, published by Addison-Wesley.

It is often useful to speak of network systems such as AppleTalk, TCP/IP, DECnet, and NetWare SPX/IPX, as being designed in a hierarchical structure, much as computer operating systems are. Network protocols said to be residing on the lower levels are required for the higher levels to function. The lower-level protocols tend to be general purpose protocols; the higher-level protocols are specialized for specific tasks. Many network systems are described in terms of the Open Systems Interconnection (OSI) model, a seven-layer network protocol architecture developed by the International Standards Organization (ISO) in the 1970s. AppleTalk was

designed in approximate accordance with the OSI model, as shown in Figure 12.11. This seven-layer structure is often referred to as a *protocol stack*.

The bottom layer of the OSI model is called the *physical layer*. In AppleTalk, the physical layer describes the LocalTalk, Ethernet, or token ring hardware, connectors, and cabling. The second layer is called the *data link layer*, which describes the EtherTalk and TokenTalk drivers. The link access protocols in this layer enable packets to be used on various physical hardware. Data link protocols are mutually exclusive; that is, only one is allowed on a single network segment.

Other protocol stacks, such as TCP/IP and DECnet, can be carried on Mac networks on top of these first two layers. This enables a Mac to participate simultaneously as a node on several network systems. Higher-level foreign protocols such as NFS can also be used with AppleTalk. Figure 12.12 shows how foreign network protocols relate to AppleTalk and the OSI model. TCP/IP, which predates the OSI model, doesn't fully fit into the seven-layer model; its protocols perform some of the functions of multiple layers. However, a broad mapping of TCP/IP onto OSI as in Figure 12.12 is useful for purposes of comparison.

The Datagram Delivery Protocol (DDP) on the network layer of the ISO model delivers a packet between sockets across internets. DDP enables processes on different network devices to exchange packets with one another. DDP also carries the network number of the destination packets and the *hop count* (the number of routers a packet has crossed since leaving its origin), both of which are used by routers to guide the packet to its destination network. DDP can be seen as the core of the protocol stack—it is what makes AppleTalk AppleTalk.

DDP is data link independent, which is why a Mac can so easily switch between LocalTalk, Ethernet, token ring, ARCnet, FDDI, X.25, or any other data link mechanism. To accomplish this, DDP uses the AppleTalk Address Resolution Protocol (AARP) to map AppleTalk's dynamically assigned node addresses with the fixed addresses set in hardware for non-LocalTalk networks.

The Routing Table Maintenance Protocol (RTMP) and Zone Information Protocol (ZIP) are used by AppleTalk routers to inform themselves of each other's presence and to the existence of AppleTalk networks and zones. RTMP sits on the transport layer, and ZIP, which requires RTMP, sits on the session layer. You would train your protocol analyzer on RTMP and ZIP packets if you suspected that a router wasn't working. Routers are also among the devices that make use of the Name Binding Protocol (NBP), which facilitates the conversion of names into numeric addresses. NBP is one of the protocols that makes AppleTalk easy to use. It is NBP that provides users with the ability to connect to printers and servers from the Chooser.

Figure 12.11

AppleTalk and its constituent protocols are designed along the lines of the seven-layer OSI model. Protocols at lower levels are required for higher-level protocols to run.

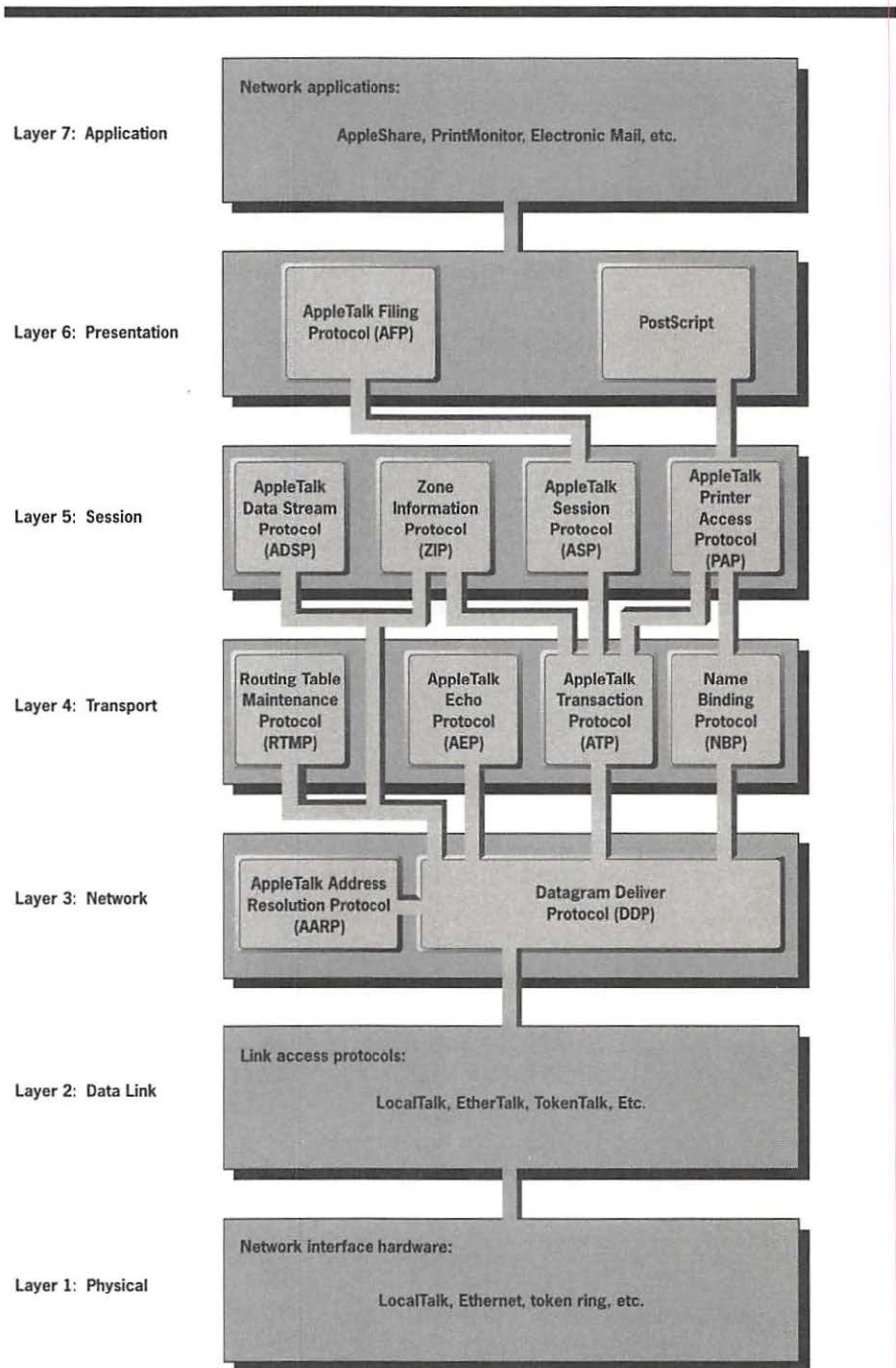

Other transport layer protocols include the AppleTalk Transaction Protocol (ATP) and the AppleTalk Echo Protocol (AEP). ATP is used by a variety of network peripherals, such as file servers and printers, to provide delivery of packets between sockets without loss of data. ATP uses the concept of a *transaction*, in which a client socket makes a request to a server socket. If a socket does not receive a reply to its request, ATP will send another request.

Figure 12.12

Foreign network protocols can also be workgroups in terms of the OSI model. Specific layers of foreign networks can be run on AppleTalk networks.

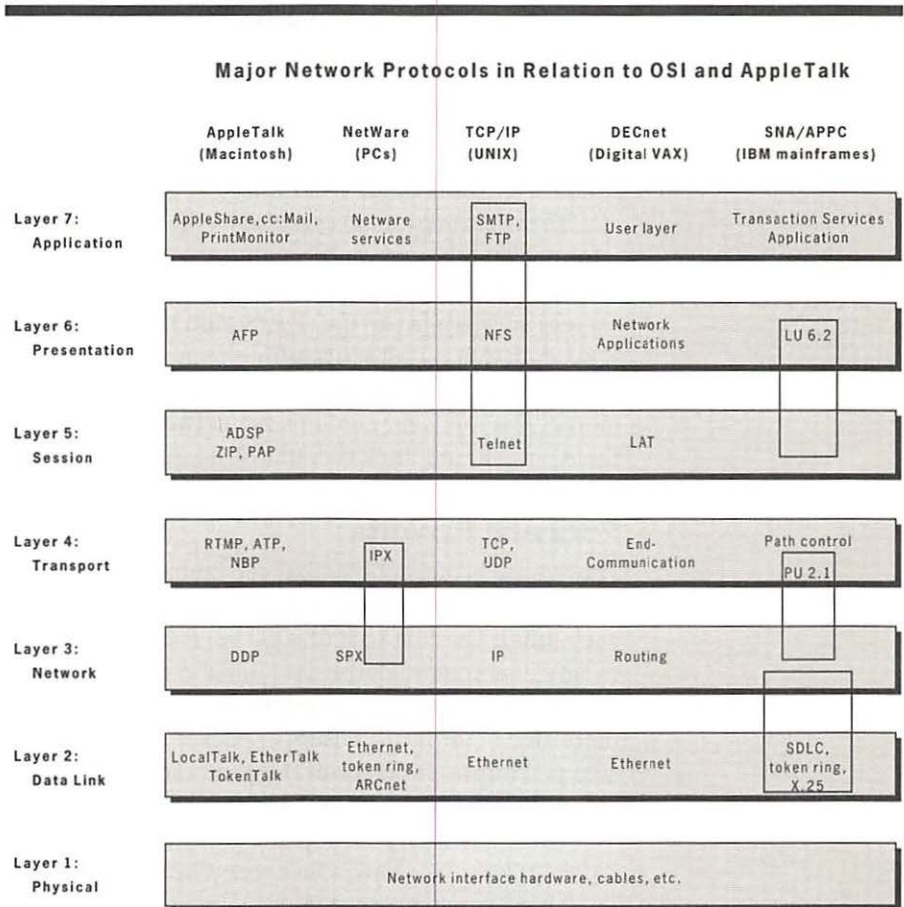

AEP is designed for testing a path between two points on a network. When an echo packet is received by a node, it sends a copy back to its origin. If you're not receiving the same number of echo packets you sent out, something may be wrong with the network connection. The ability to send echo packets is included in a wide variety of network tools, from asset managers to packet analyzers.

The AppleTalk Data Stream Protocol (ADSP) is used by a variety of applications to open up efficient point-to-point communications between sockets. Terminal emulators use ADSP to open a terminal session over an AppleTalk network, similar to the way Telnet is used on TCP/IP and LAT on DECnet. ADSP is also used by some of the inventory management programs, such as Status•Mac, and Retrospect Remote uses it to back up hard disks over a network. Orange Micro's Grappler Share uses ADSP in place of PAP to share normally non-network serial printers across a network.

Other session layer protocols include the AppleTalk Session Protocol, which is used by the Apple Filing Protocol to keep a continuous connection between a shared volume and the client Mac that has it mounted on the desktop. The Printer Access Protocol (PAP) is used by networked PostScript printers to receive data from Macs.

The presentation layer presents the network data to a Mac application in a format that the software can understand. For instance, the Apple Filing Protocol converts data packets into a format that AppleShare-compatible file servers and clients can use. PostScript, the page-description protocol, presents data that a PostScript printer can understand. On TCP/IP networks, Sun's network filing system (NFS) fits in the presentation layer of the OSI model. The top layer contains the network applications themselves, such as the AppleShare File Server and Print Server.

Perusing Packets

Packets are groups of bits that can contain data and commands. Protocols are the rules, not the substance, that network devices use to communicate with each other. The first part of a packet is called the *header*, which is followed by any data that might be contained in the packet. The header contains socket, node, and network addresses of the destinations and source and is, therefore, of interest to users of packet analyzers. Packet headers can also give you information about the protocols being used. The end of a packet is identified by a frame trailer, which is specified by the link access protocols.

There are also types of packets associated with different protocols. Most AppleTalk packets have a link access header (LocalTalk, EtherTalk, etc.) and a DDP header, which are at the beginning of the packet (see Figure 12.13). Other protocols above DDP send out their own specialized types of packets that include link access and DDP headers. For instance, routers send out ZIP query and reply packets to exchange routing table information. A file being transferred from an AppleShare server is carried in a sequence of AFP packets.

Many of the protocols (including the data link protocols) specify the use of two types of packets, control packets and data packets. Control packets are responsible for much of the protocol overhead associated with AppleTalk networks. AARP packets are always control packets. Data packets are

not necessarily initiated by users. RTMP, for instance, sends routing table information in data packets. Control packets can be recognized as such by protocol analyzers because they are smaller than data packets.

Figure 12.13

This generic packet shows the overall design of most AppleTalk packets. The link access and DDP headers contain the source and destination information.

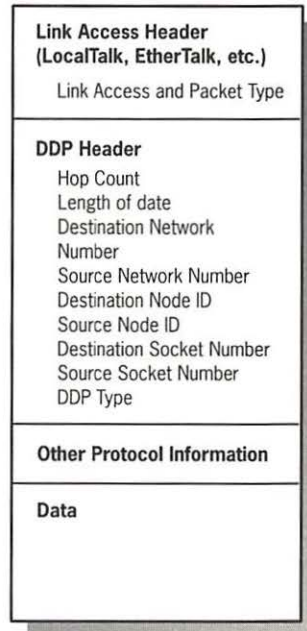

Poking Packets with Software

Macs on a network normally read only packets that are addressed to them and ignore the rest. Protocol analyzers running on a Mac take over the Mac's network interface hardware and instruct it to read all the packets that are passing over the network cables. The software can then record, sort through, and dissect the packets for your use.

Using Mac software analyzers is a good way to troubleshoot problems as well as to take a close look at network performance and error rates. You can easily tell if a device is malfunctioning and spitting out garbage packets, or you can create packets of a certain type and measure how the network reacts. Software analyzers are cost effective, easy to use, and portable. Just carry around the floppy disks and stick them in any Mac to analyze at a moment's notice. Or, install the packet analyzer on a PowerBook. With an Ethernet adapter, you're ready for any network, Ethernet or LocalTalk, AppleTalk or completely non-Mac, and you are still carrying and spending less than you would with a hardware analyzer.

The software packet analyzer leaders are the AG Group, with its LocalPeek and EtherPeek, and Neon Software, with NetMinder LocalTalk and NetMinder Ethernet products. Both sets of products are powerful, with good user interfaces and similar feature sets. Early on, NetMinder Ethernet was known for its more thorough packet decoding than EtherPeek, and the AG Group had more troubleshooting features. However, because both companies do frequent upgrades, the differences in capabilities between the two approaches has been shrinking, making any kind of comparison of features and interfaces short-lived. I can say that both have better interfaces than the hardware protocol analyzers and are good at providing English names of source and destination nodes and in helping you identify entities in network traffic.

For all their ease of use, these packet analyzers are no protocol wimps. They can decode a variety of network protocols, including Novell NetWare (SPX-IPX), Banyan VINES, DECnet, TCP/IP, SNMP, XNS, and of course, AppleTalk, from the link access protocols all the way up through AFP. However, most of your troubleshooting time will be spent working with the lower-layer protocols.

A common way to use a protocol analyzer is to collect and record all packets being transmitted over the network, and narrow down the packets to the ones that interest you (see Figure 12.14). The elimination of unwanted packets is done with filters. Using filters lets you keep or discard all packets with a certain source or destination address, protocol, or even a bit string (an exact sequence of characters) inside the packet. You can also configure multiple filters at once to quickly narrow down the search.

Another way to narrow down the data you need to sift through is to throw away the data portion of the packet and just keep the header; this is called *packet slicing*, a software setting that keeps only the first few dozen bytes of each packet. However, in case you are interested in all of the data, you can unwrap a packet's contents at the byte level.

You can automate the collection of packets by using triggers. You can set the analyzer to start or stop capturing packets based on the time of day or by a network event, such as the receipt of a certain packet or protocol. You can also collect statistics on packet size, bandwidth, protocols, usage, and errors (see Figure 12.15).

There are fewer tools for token ring. MacToken from EDI Communications was the first Mac-based analysis tool for token ring networks. MacToken runs on a Mac with a token ring network interface card from Asanté or Avatar. However, the Mac and PC nodes on the token ring network can use any hardware.

MacToken has some of the same functionality of the Mac-based Ethernet products, only tuned to token ring technology. Device addresses, network

numbers, error counts, and ring status can be displayed, as can information for one station or for the whole network. Network traffic and other statistical information can be presented in graphs.

Figure 12.14

A packet analyzer, such as Neon's NetMinder Ethernet, can display a list of all packets captured from a network.

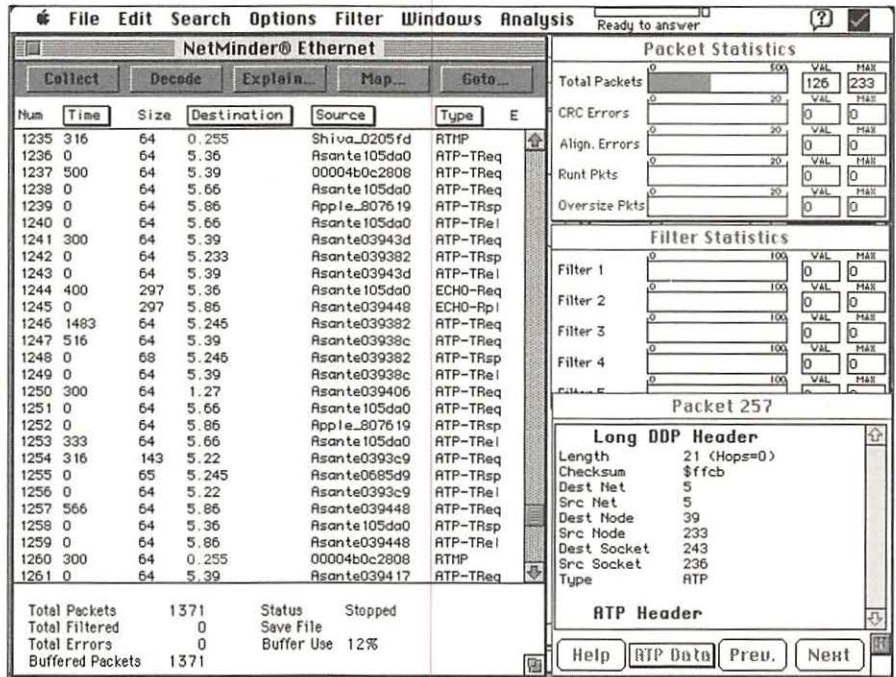

MacToken can recognize and interpret many important AppleTalk protocols, including RTMP, ZIP, ATP, ADSP, AEP, and NBP. It can also be used to troubleshoot Novell NetWare and IBM SNA token ring networks, and can detect the logical link control (LLC) protocol, a low-level token ring protocol. A table can display the ring's next active upstream neighbor for each node.

Poking Packets with Hardware

Hardware packet analyzers consist of PC-based hardware and software. The operating system is usually DOS or a slightly altered DOS system running on a portable (though definitely not laptop) Intel 80386-based PC. The adapter for Ethernet or token ring (LocalTalk is not always available) is usually tuned for high performance. These units cost 5 to 6 times more than do Mac software packet analyzers, ranging between \$10,000 and \$30,000. In addition,

hardware analyzers are not as easy to use as the Mac-based protocol analyzers, and require more training.

Figure 12.15

The statistics window of AG's EtherPeek protocol analyzer can be used for spotting trends.

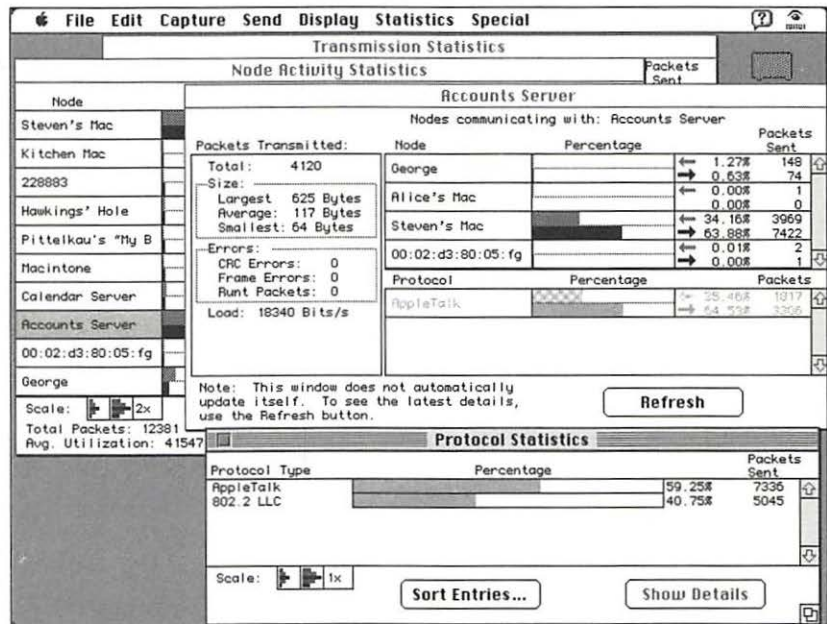

Hardware protocol analyzers such as Network General's Sniffer, the leading hardware protocol analyzer, are designed for people who do packet analysis on a daily basis, particularly on large networks. The units are optimized for capturing as many packets as possible, and may be faster than your Mac and its Ethernet card. Network General's Sniffer uses its own version of DOS geared toward that purpose. Hardware analyzers can also decode SNA, X.25, or X Window packets.

However, not all hardware protocol analyzers support AppleTalk. This means that you'll be able to detect Ethernet packets and read the Ethernet header information, but you won't be able to decipher the DDP header or count RTMP packets. (The lack of AppleTalk support is somewhat surprising, considering the widespread use of the protocol. At a Network General product introduction, an analyst invited to speak for the company reported that over 45 percent of Network General's target customers used AppleTalk, with a good proportion using LocalTalk, yet at the time, the Expert Sniffer supported neither.)

Hardware analyzer vendors are also offering artificial intelligence in the form of expert systems that aid in recognizing and diagnosing problems. Network General's Expert Sniffer will offer opinions on the condition of a network, as well as possible causes for a problem. This insulates the Sniffer users from the dirty details of packet analysis and speeds up fault diagnosis. For instance, Expert Sniffer can analyze 5,000 packets in 10 seconds to arrive at a diagnosis.

Hewlett-Packard's Fault Finder software, running on its HP 4980 Network Advisor series, is a bit more friendly than the Sniffer, mostly because it runs under Microsoft Windows, on top of unaltered DOS version 3. Fault Finder uses deductive reasoning to eliminate possible causes of a problem, and can offer hypotheses and test them (with user approval) on the network. It can also take measurements over time and learn what a baseline normal condition is for your particular network. Fault Finder then uses this baseline to assess deviations from the baseline.

■ Looking Ahead

This chapter has described all of the major categories of tools used by AppleTalk network managers and administrators, ranging from simple utilities at just over \$100 to complex lab equipment costing tens of thousands of dollars. Some of the tools support large internets—even wide-area networks held together by telephone lines and satellite links. At the same time SNMP was adopted for AppleTalk troubleshooting, Apple introduced a leaner protocol that does the work of RTMP and ZIP over wide-area networks. The AppleTalk Update Routing Protocol is now an important part of the Macintosh wide-area network. I'll describe the wide-area networking options for your Macs in the next chapter.

- *Built In: The Apple Update-Based Routing Protocol*
 - *Adventures in WAN Routing*
 - *The Carrier Media*
 - *Dueling Protocols: OSI versus TCP/IP*
-

C H A P T E R

13

Networks across the Globe

THE AGE OF GLOBAL COMMUNICATIONS BRINGS US THE OLYMPIC Games, enables us to use our credit cards when traveling far from home, and instantly informs us of events in far-off lands. Much of the same technological infrastructure that makes these actions possible also brings us the ability to link computer networks that are widely separated, so that each can share the resources that are available on the other. This is accomplished through the use of a *wide-area network* (WAN), a connection of networks and internets that links sites in different states, countries, and on different continents.

Just as an internet is described as a network of networks, a wide-area network is often an internet of internets including at least one link by radio, telephone, or satellite. An internet that is spread over a few blocks or miles can be referred to as a *local internet*. Wide-area networks are often used to connect the local internets at different sites for database access, messaging, and file transfer. WANs are also used to connect companies with their clients and suppliers. By installing the appropriate hardware, a small branch office can use a WAN to keep in data contact with the main office or a service agency.

Routers, gateways, and converters are used to connect a local area network or internet to the wide-area network. The routers used are special routers that communicate with normal LAN or local internet protocols in one port and WAN protocols in another. I've previously mentioned the encapsulation of AppleTalk inside of foreign protocols as an alternative to running the actual protocol on all your Macs. You don't always have to build your own WAN; instead, you can make use of existing ones for long-distance communications.

As with local area networks, WANs employ their own plumbing technology to carry signals over the distance. The main plumbing choices are public or private lines offered by the telephone companies. Here you'll find a wide variety of choices, costs, speeds, and bandwidth. For the past few years, telephone companies have been expanding their capability to offer a promising new type of line service, *integrated services digital network* (ISDN), which provides a high bandwidth and the ability to combine digital voice and data over the same line. Public or private satellite communication is another option for connections between very distant sites.

When you are connecting networks, you have to consider network protocols. CCITT X.25 is an industry standard data link protocol established for wide-area networks. You can even send AppleTalk over the connection for very large networks of thousands of nodes, thanks to a relatively new AppleTalk routing protocol. In large mixed networks, it is often more convenient to make use of a more efficient protocol. In the United States, TCP/IP has become the de facto standard network protocol used for wide-area networks within the United States. However, if you need to communicate with networks in Europe, the Open Systems Interconnection (OSI) is more widely used there.

Built In: The Apple Update-Based Routing Protocol

Until recently, running AppleTalk on a wide-area network has been problematic. Although AppleTalk Phase 1 was designed for small networks, AppleTalk Phase 2 was designed only for local internets. There was no provision for wide-area networks, and router vendors used different, and sometimes conflicting, proprietary routing protocols. To correct this deficiency, Apple worked with an industry standards group called the Internet Engineering

Task Force (IETF) to publish the Apple Update-Based Routing Protocol (AURP). AURP was added to AppleTalk Phase 2 in mid-1992 for the purpose of improving routing of AppleTalk over wide-area networks.

One way to route AppleTalk packets between widely separated destinations is to encapsulate them inside foreign packets and route them through a large wide-area internet (see Figure 13.1). As was described in Chapters 6 and 8, this technique is known as tunneling.

AURP is especially useful for tunneling AppleTalk through foreign WAN internets, typically TCP/IP. Tunneling is easy to use—to AppleTalk users, the AppleTalk internet at another end of a tunnel appears just as another port of a large AppleTalk internet. To the local AppleTalk internets, the foreign WAN appears as a cloud through which AppleTalk passes through unchanged (see Figure 13.2). In this way, a tunnel acts as a virtual data link.

Figure 13.1

One way to route AppleTalk packets between widely separated destinations is to encapsulate them inside foreign packets (such as TCP/IP) and route them through a large internet.

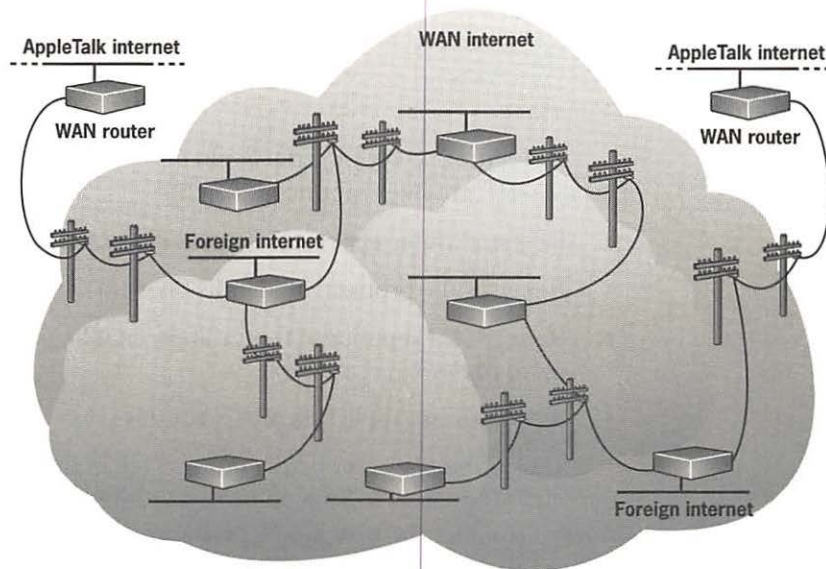

AURP allows network designers to connect large AppleTalk internets together through tunnels with the resulting AppleTalk WAN internet generating little or no traffic. AURP replaces both RTMP and ZIP (Routing Table Maintenance Protocol and the Zone Information Protocol, both mentioned in the last chapter) for the wide-area connection. AURP is used by WAN routers, but is not used on the local internets. To take advantage of AURP, you need a wide-area router that supports AURP. Many AppleTalk Phase 2

WAN router vendors offer upgrades to their routers. Nothing needs to be added to the Macintoshes on the network.

Figure 13.2

Encapsulating AppleTalk through foreign WAN links (such as TCP/IP) is often represented as a tunnel through a cloud, since the effect is of a tunnel of AppleTalk packets passing unchanged through the foreign WAN internet.

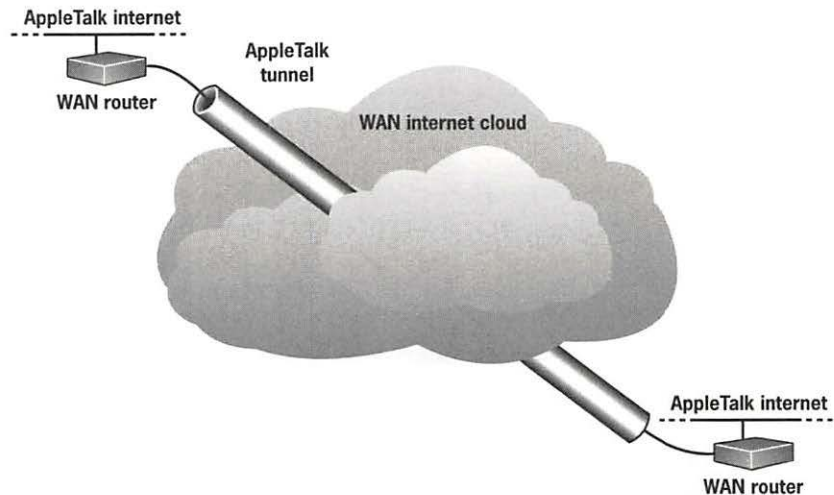

In addition to the transportation of AppleTalk protocols through tunnels, AURP provides four main benefits:

- Reduces router-generated traffic on a WAN
- Resolves the problem of identical network numbers
- Reduces the number of router hops, enabling a packet to travel through more routers
- Standardizes AppleTalk WAN routing

These benefits, described in more detail in the next section, succeed in enabling AppleTalk to be used on bigger internets than before. But AURP doesn't completely solve all the problems of wide-area networking with AppleTalk. There will be gradual improvements that should involve minor upgrades to routers. These will address some of the limitations dealing with redundant routing described in the next section.

Router vendors would like to see the protocol overhead cut further to improve router performance. AURP could even be replaced by a more advanced routing protocol at some later date. TCP/IP's OSPF protocol and OSI's ISIS are both more efficient than AURP currently is. Other features are not yet available anywhere. For instance, it would be convenient if applications could reserve a chunk of bandwidth that would guarantee real-time

transmission of video and sound. Other features, such as the ability to automatically split traffic between alternate routes, are also being considered for the future.

Still, the fact that AURP is now available should greatly increase the size and number of AppleTalk wide-area internets. Through tunneling, it is now possible to create AppleTalk internets of thousands of nodes. In addition to large companies forming their own AppleTalk-through-TCP/IP internets, Apple hopes to create the AppleTalk Internet, a large private interconnected WAN of AppleTalk networks similar to the TCP/IP Internet mentioned in Chapter 8. In fact, the AppleTalk Internet would tunnel through the TCP/IP Internet. The difference would be that Mac users wouldn't have to deal with strange TCP/IP addresses and character-based commands. TCP/IP would be completely transparent.

■ Adventures in WAN Routing

When studying wide-area networking, it's good to start with a bird's-eye view of the whole setup and gradually zero in on the details. From your vantage point, WAN routing is the first thing you'll notice.

WAN routing is fairly simple for connecting to networks over a long distance in a point-to-point manner—it's basically an extension of internet routing, except more expensive routing hardware is needed. Routing turns much more complex when tunneling AppleTalk through large non-AppleTalk WAN internets.

Basic WAN Routing

WAN routers usually have more intelligence than LAN routers, but otherwise are very similar to ordinary internet routers. Some manufacturers offer versions of their internet routers that have one or more WAN ports added. Other WAN routers come with expansion slots in which you can add hardware for different types of WAN links. Reputable manufacturers of WAN routers include Cayman, Cisco, Engage, Transware, and Shiva.

The WAN router usually sits between a local internet and an interface box to the carrier line, although some WAN connections can be made directly to the router. The simplest type of WAN routing is the use of half-routers over an ordinary asynchronous dial-up connection, as previously mentioned, for point-to-point connections over a public telephone line or a leased line. Full-routers can also provide point-to-point connections with faster synchronous connections. A multiport WAN router can connect several internets to a single centralized backbone, as shown in Figure 13.3.

Figure 13.3

A multiport WAN router can connect several branch offices to a corporate backbone.

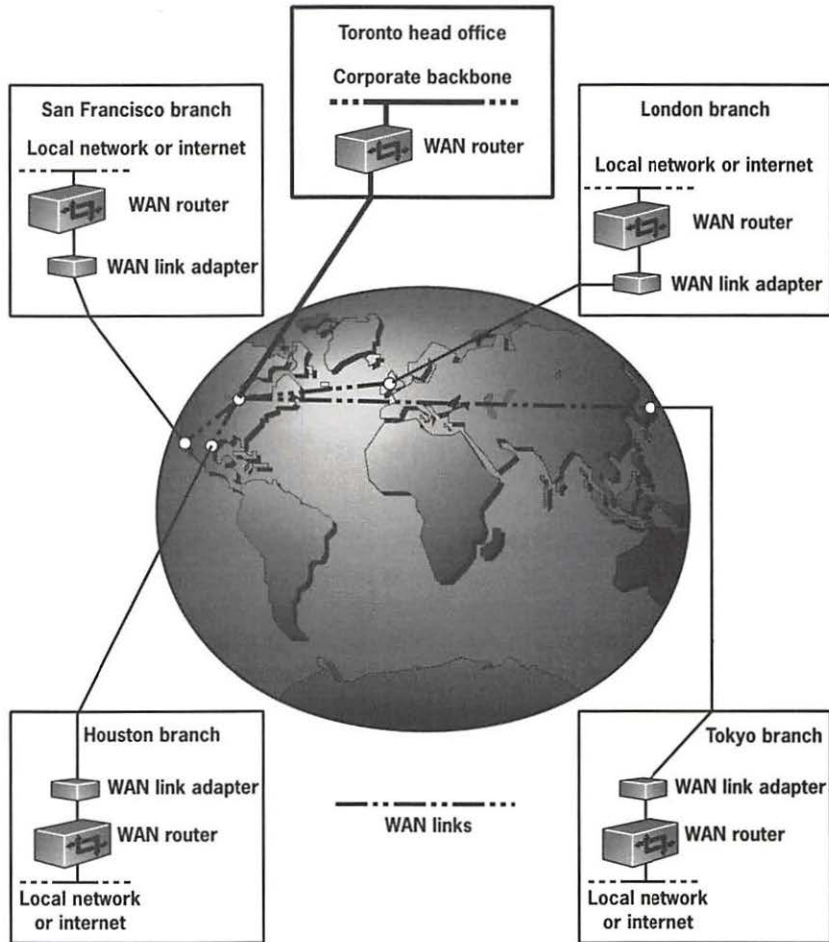

You can do away with AppleTalk altogether, and just run TCP/IP to every node (with MacTCP, for instance), a strategy that makes sense in situations where a few Macs are connected to a network of mostly UNIX workstations or PCs. Running straight TCP/IP certainly simplifies WAN routing while improving performance. However, this is not a good idea for big Macintosh networks, since you'd be losing the plug-and-play features of AppleTalk, such as its dynamic addressing. Most Mac users (and network administrators) would rather not have to manually enter node addresses to configure their Macs and to communicate with other Macs on the WAN. In addition, the Chooser loses some of its usefulness in an all TCP/IP network, since TCP/IP doesn't have an equivalent to AppleTalk's logical zone names.

For these reasons, you may want to consider routing AppleTalk over a WAN with AURP.

AURP Routing

AURP is an open standard that can be implemented by any router vendor. Each vendor can choose which features to implement in its routing software. The best routers allow the network administrator to select the AURP features best suited to a specific environment. Although AURP universally creates much less traffic than the RTMP and ZIP protocols it replaces, other generally beneficial features have drawbacks that need to be considered.

Reducing WAN Router Traffic

As discussed in Chapter 6, normal AppleTalk routers broadcast every 10 seconds or so to keep each other updated. This keeps router information current, but the network traffic generated by a lot of router broadcasts can really choke a big internet. Most of the time, there are no changes in an internet's configuration. Internets are usually fairly stable, with routers being added or removed infrequently. AURP is called an update-based routing protocol because it sends out routing table information only when a change has been made. The router updates that are being broadcast on the local internets are not transmitted over the WAN link.

With AURP, the only time a WAN router sends out information over the WAN is when it receives information that there has been a change on the internet. The change could be a new LAN router added or deleted, a new zone name, or a WAN router, itself, added or removed. When a WAN router is about to be shut off, it will send a message around informing the other WAN routers that it is no longer in service. If a WAN router unexpectedly goes down without sending a shutdown message, other AURP routers have the ability to detect its absence during normal routing functions, and routing tables will be updated.

Resolving Network Number Conflicts

A common problem on AppleTalk WAN internets is the occurrence of networks with the same network identification number. As you may recall from Chapter 6, individual AppleTalk networks on an internet can be assigned a range of network identification numbers. Two networks with the same number will confuse the routers and cause problems. Although there are 65,536 possible numbers from which to choose, network managers often think alike when assigning network number ranges. Without AURP, network managers need to call ahead before connecting to an internet to make sure their network numbers are indeed unique.

If the network managers desire, AURP can map the various AppleTalk numbers onto unique identification numbers for use by the WAN. Unique WAN numbers would be reserved for WAN use only by the network managers. Two networks with the number 42, for instance, might be identified on the WAN as networks 100 and 101.

The only problem with AURP's current mapping scheme is that it forbids the use of redundant routes (described in Chapter 6), or loops, on the WAN. The problem occurs if a WAN router sees the same network number coming from two directions of a loop; it may treat these two readings of the same network as two networks with the same number. Apple has indicated that the ability to use loops in a remapped WAN internet may be added to AURP at a later date.

Another type of remapping helps reduce traffic within local internets. AURP can *cluster* network numbers, a process that represents several networks within an internet by a range of numbers, making the group of networks on an internet appear as a single network. For instance, if the actual network numbers in one part of an internet were 42, 135, and 598, they might be mapped as 101, 102, and 103. Clustering would further represent these networks as the single network with the range 101 to 103. The benefit of clustering is that within the local internet, the size of the RTMP routing tables, and therefore network traffic, would be greatly reduced.

A drawback of clustering is that it is static. When a network or zone with a cluster goes down, the AURP WAN router that administers the clustering could only inform the local routers of this fact by reclustering. Assigning new cluster numbers would temporarily disconnect the local internet from the WAN. However, intelligent router software could get around this problem by forcing reclustering at convenient scheduled times.

Reducing Router Hops

Within AppleTalk, a packet's *hop count*, a measure of the number of routers a packet has passed before getting to its destination, can't go over 16. This is a limitation in a large WAN. AURP can reduce a packet's hop count, not by lowering the number of routers the packet goes through, but by altering the hop count number recorded in the packet's header.

Normally, a packet is not forwarded if a router determines that the packet needs more than 16 hops to reach its destination. When an AURP sees that the hop count will be over 15, it can reduce the hops written in the header before forwarding the packet into the AppleTalk internet (see Figure 13.4). AURP reduces the number of hops by the exact number it needs to reach its destination.

As with network number mapping, with hop count reduction, you can't have any redundant connections or loops in an internet backbone. Like

network number remapping, hop count reduction is an optional feature that does not have to be implemented to run AURP.

Figure 13.4

AURP enables a packet to travel further than the 16-hop limit imposed by AppleTalk by reducing the hop count number the packet carries with it.

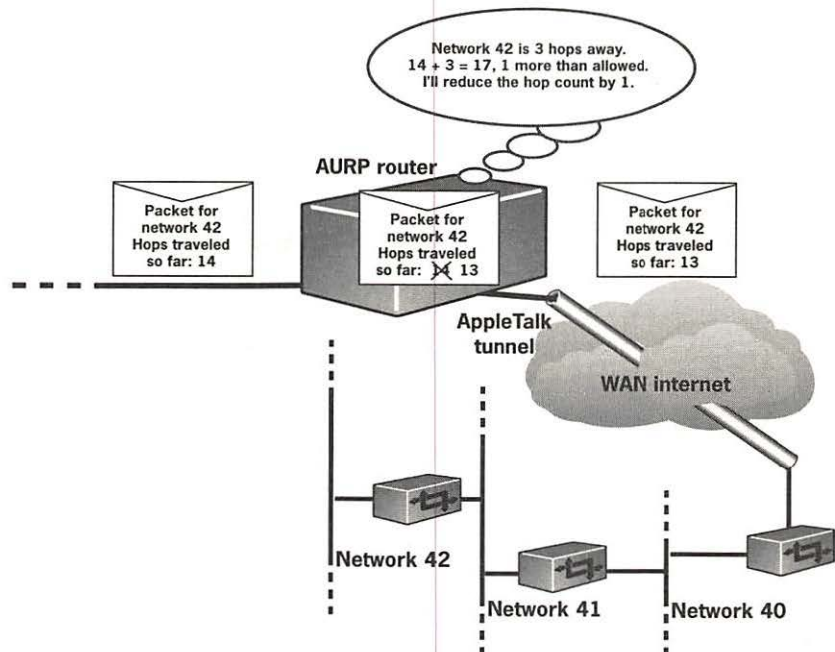

Standardizing WAN Routing

Another benefit of AURP is that it is a standard method of routing AppleTalk over WANs, enabling diverse groups to connect. AURP also standardizes techniques to hide networks and printers and other devices over WANs. Apple made sure it would be a standard that router manufacturers adopted by developing AURP through the IETF standards group. Before AURP, there was a group of ad hoc and sometimes conflicting methods of tunneling AppleTalk through TCP/IP, some of them created by UNIX programmers at universities and some by router manufacturers. These methods can still be found at sites, but will be phased out over a period of years as people replace or update their routers to support AURP.

The most common pre-AURP WAN protocol is a proprietary protocol developed by Cayman for its GatorBox routers and used by others to become a de facto standard. Another protocol still used is the Kinetics Internet Protocol (KIP), described in Chapter 8. There are several versions of this public

domain protocol floating around, but most WAN routers that support AppleTalk support KIP.

A freeware protocol popular at universities is ATalkAD (AppleTalk Administration Daemon), a process that runs on a UNIX host on a local internet connected to a WAN. ATalkAD provides a tunnel into a TCP/IP network at the request of any router. A file called ATalkAB (AppleTalk Administration Table) is used to define the tunnels by providing the IP addresses and the AppleTalk numbers and zone names for the ends of the tunnel. ATalkAD is a rather ad hoc system, with lots of versions floating around, some not completely compatible with AppleTalk Phase 2.

A Look at AURP Routers

In AppleTalk, a WAN router that has at least one port to an AppleTalk internet and another to a tunnel is called an *exterior* router: it provides a port to outside the local internet. An exterior router is both a router in the AppleTalk internet and an end node in the foreign network that supports the tunnel. It does not, however, do any routing of the foreign protocol. RTMP and ZIP are used on the AppleTalk side of the external router, and AURP is used on the tunnel side (see Figure 13.5).

An exterior router maintains a table of other exterior AppleTalk routers on the tunnel. An exterior router broadcasts information on the tunnel concerning only the routers in its local internet. This is an improvement over RTMP routing, in which every router on an internet keeps information on every other router on the entire network. Exterior routers also encapsulate outgoing AppleTalk packets inside those of the foreign network and decapsulate incoming packets.

Connecting Tunnels

AURP supports multiple-end point tunnels, which allow any number of AppleTalk internets to connect to the tunnel by using an external WAN router on the foreign internet. AURP also supports point-to-point tunneling, in which only two AppleTalk internets join the tunnel. External routers that support the appropriate network protocols can also function to connect tunnels of different WAN internets (see Figure 13.6). This would provide a link between AppleTalk networks connected to a DECnet tunnel and AppleTalk internets connected to a TCP/IP internet. Instead of the DECnet tunnel, you could have a point-to-point connection over a leased T1 line.

An exterior router can also be used to connect two tunnels on the same WAN internet (see Figure 13.7). If the setup is configured as a partially connected tunnel, exterior routers 1 and 3 can't see each other, but external router 2 can see both of them. This type of setup can result from a

misconfigured system, or can be created purposefully to prevent users on the two end internets from accessing each other's internets. The exterior routers can also be configured so that the tunnels are fully connected, in which case, routers 1 and 3 would be about to access each other.

Figure 13.5

An external router connects an AppleTalk internet to a tunnel. It contains the RTMP router function and an AURP converter, but does not route TCP/IP packets.

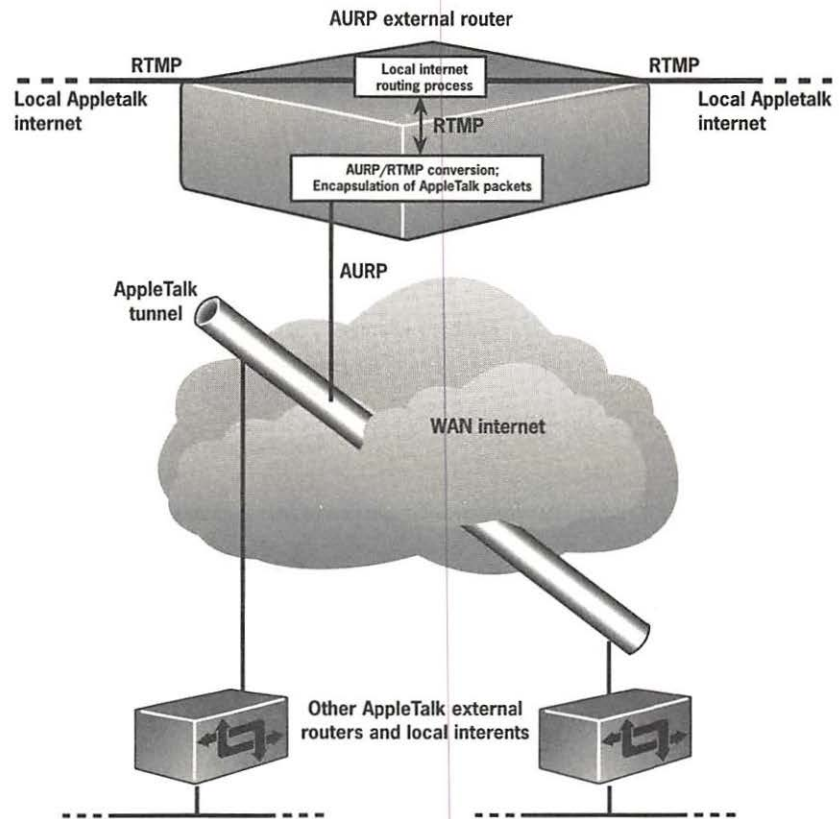

■ The Carrier Media

Carrier media are the long-distance lines and switches that carry your WAN data over hills and valleys and beyond the oceans to its destination. Many of the carrier lines are provided by the major phone companies, although there are some less familiar suppliers of carrier services as well. There is nothing Macintosh or AppleTalk specific about WAN carriers—to a phone line, data is data.

Figure 13.6

Connecting multiple multipoint tunnels on different WAN network systems

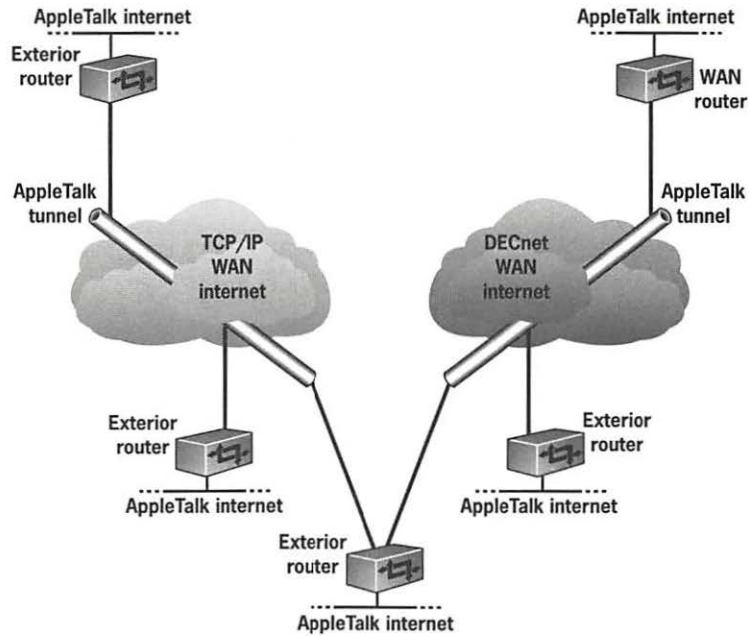
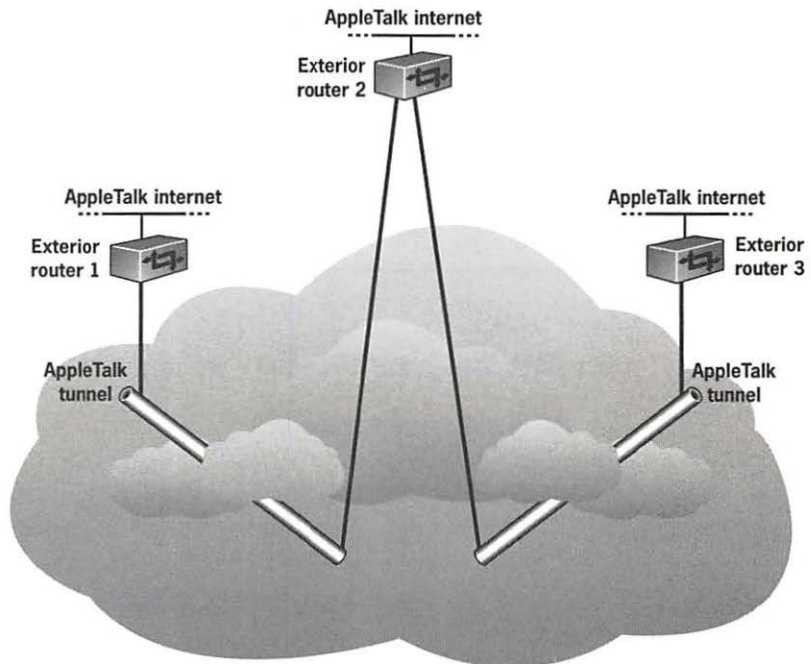

Figure 13.7

An exterior router can connect two tunnels on the same WAN network system.



There are two types of carrier service suppliers. The first is the so-called interexchange carriers, which provide long-distance connections between major phone exchanges located in big cities. These include such companies as the big three long-distance companies, AT&T, MCI, and U.S. Sprint. The second type of suppliers is the local carriers, which sell service between major exchanges and a home or building. This division of local and long-distance service is a result of the breakup of Ma Bell and doesn't exist in countries outside of North America. However, depending on your location, you can sometimes arrange for a WAN link through a single company within the United States.

The analog public telephone lines, which you can use with a network modem and a half-router on each end of the connection, are at the bottom of the carrier media list. Public phone lines are the slowest, noisiest, and least secure carrier for establishing WAN links. As mentioned in Chapter 3, public phone lines can't carry more than 38.4 Kbits (kilobits) per second, and most lines can support much less. They also come with the smallest monthly fees, but can end up being very costly due to the low bandwidth they will support.

For permanent WAN connections, most organizations lease public or private digital lines with synchronous connections. Digital lines vary greatly in price; but in general, the higher the bandwidth, the more the monthly fee. Satellite links are another option for connecting the pieces of a WAN.

Which type of carrier you choose depends on the needed bandwidth and cost. The length and bandwidth are the main determining factors in the cost of services. Individual links in a WAN can use different carrier media; some multiport routers can support mixed carriers. This is helpful, since the price of a carrier line is often determined by your location relative to the main switching center.

Switched 56

Switched 56 (or SW56) gets part of its name from its bandwidth: 56 Kbits per second. As with a local area network, the actual data throughput will be less, depending on the overhead of the protocols used. The term *switched* comes from the method of establishing the link, called circuit switching. Every time you initiate a long-distance connection, a different path is established through a vast network of switches. The bandwidth is guaranteed as long as the link is maintained. This is how ordinary telephone calls are handled, except that a modem or telephone call uses analog signals, and a switched 56 link is a digital link. Switched 56 also provides multiport capabilities, which means you can establish a link to any number of local area networks that are connected to the SW56 cloud. A *data service unit* (DSU) is used to connect a network router to an incoming switched 56 line.

Switched 56 service often runs the X.25 protocol (described later in the chapter). Higher-speed switched service, such as switched multimegabit data service (SMDS), is also available from carrier service providers. A third packet-switched protocol, Frame Relay, is also becoming popular because of its highspeed capabilities.

T1 Lines

A leased T1 channel provides a point-to-point line connection with a bandwidth of 1.544 Mbits (megabits) per second. For the sake of comparison, this is about six times higher than a LocalTalk LAN and less than one-sixth the bandwidth of Ethernet.

T1 services are not cheap, with a monthly fee in five figures for distances of 1,000 miles or more. Fractional T1 is a less expensive option that gives you a piece of the 1.544 Mbits per second bandwidth. These are typically in increments of 64 Kbits per second. On the high end, a T3 line can provide a bandwidth of 45 Mbits per second, at a cost of 9 or 10 times that of T1. You can also lease multiple T1 lines to increase bandwidth or to secure backup lines to guarantee a continuous connection. There are T1 routers available that will automatically check lines and route data through an open line.

To connect a network to a T1 line, you'll need to connect the T1 line to a channel service unit (CSU). This plugs into another box called a data service unit (DSU). You can also mix voice and data on your T1 line with a multiplexer, a device that creates multiple channels on a link by intermixing different lines in an efficient manner and separating incoming multiplexed channels. Equipment is also available that combines CSU, DSU, and multiplexer functions in different combinations.

Satellite Communications

Satellites are a good means of establishing a WAN link over very long distances. Most communications satellites circle the Earth in a *geosynchronous* orbit, that is, once every 24 hours, so that their position in relation to the ground is always the same. Usually the position is near the equator. From its vantage point out in space, a satellite can relay a signal between most points on a continent. Intercontinental links are formed with ground relay stations that lie within the sight of two or more satellites (see Figure 13.8). Networks of a dozen or more satellites can service the whole world. These include extra satellites to keep the network up in case one or more fail.

Satellite links offer a certain amount of reliability not found with ground lines, since they aren't affected by bad weather or man-made calamities.

For very long distances such as those that involve crossing oceans, satellite service is more economical than land lines. Unlike land lines, satellite

services don't charge more for longer distances. However, there are some speed penalties involved with satellite communications. The most important effect is satellite delay. Because a geosynchronous communications satellite typically hovers some 23,000 miles above the equator, it takes a signal traveling at the speed of light a little more than a quarter second to make a round trip from Earth to satellite. If it is a very wide link, such as one between British Columbia and Australia, it requires a signal to be bounced off of several satellites, and the delay is longer.

Figure 13.8

Satellites can form a global network link through relay stations that can see at least two satellites.

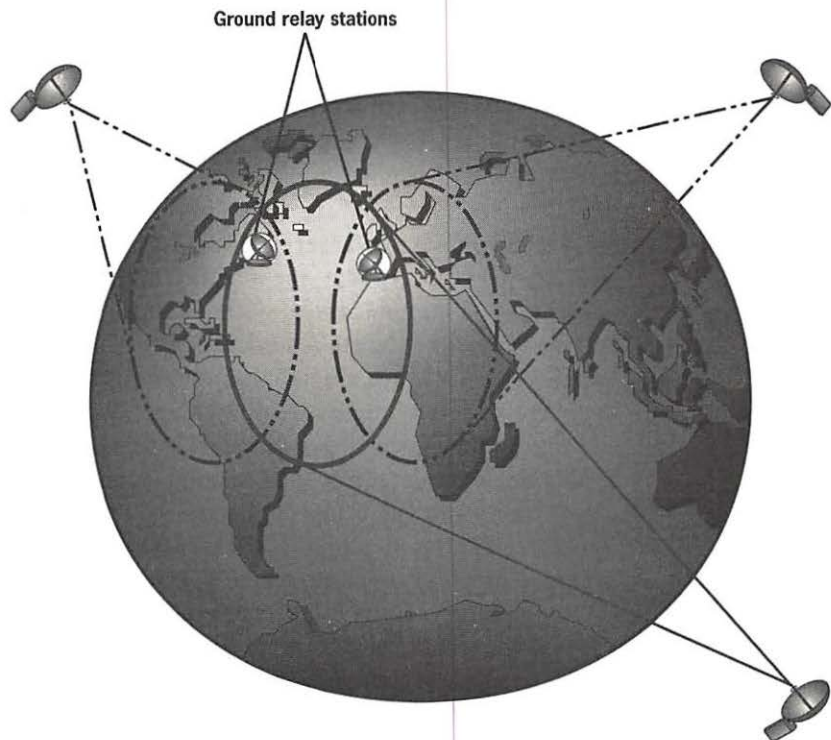

WAN applications can compensate by sending data in big batches rather than in multiple small batches. This reduces the number of acknowledgment packets that must be sent. One way to do this is to have the application send a lot of packets at once. Another technique is to automate the collection of transactions, files, and electronic mail, and the transmitting of data, so that they occur together in batches. Real-time user interaction, such as live database browsing, is not practical over satellite links.

Satellite networks can be public or private. Most companies don't buy their own satellites (or send their own space shuttles up to fix them), but instead lease satellite services and equipment from satellite technology companies. Satellite access can be through cable to a big leased or public satellite terminal somewhere, or through a private transceiver dish. Small satellite dishes and the associated hardware that you see sometimes next to chain stores or in people's backyards are called *very small aperture satellite terminals* (VSAT). Although the bigger satellite terminals can move data at T1 bandwidths, VSAT satellites typically supply only 19.2 Kbits per second. Routers are available that can interface with various types of commercially available satellite services. SyncSatellite from Engage Communications is an AppleTalk router that can operate at bandwidths from 9.6 to 500 Kbits per second.

ISDN: Networking in the Nineties

What would you say if someone offered you the bandwidth of T1 at a cost just slightly more than that of normal telephone service, and with connections to individual computers? Not only that, but you could disconnect your current telephone service, because this connection includes voice as well. This is the promise of the integrated services digital network—ISDN—a worldwide communications system that is slowly coming on-line in more and more places in North America, Europe, and Japan.

ISDN is a multichannel digital communications link that integrates a long-distance computer network with telephone and fax on a single line. In addition to the digital network, ISDN is designed to support new computer applications that integrate the telephone and the computer. This includes the use of sound and video, and connectivity to new consumer-level devices, such as Apple's hand-held personal digital assistants (PDA). AppleTalk can be routed over ISDN to create AppleTalk WAN internets.

One of the reasons ISDN can replace the public telephone service is that ISDN is the public telephone system—or at least, it will be—when the telephone companies complete the upgrade of the public telephone network to a completely digital network. Most of the long-distance links between phone companies are already digital. The links between the central switching office and the office or home are still mostly analog at this time. However, the local baby Bell operating companies have committed to ISDN, and have been gearing up for ISDN for the past few years, replacing analog switches with digital systems that have the ability to deliver digital service to your doorstep. In addition, the new switching offices being set up are equipped with digital switches.

Whether you can get ISDN service depends on your location and whether the telephone company switch near you supports ISDN. Your chances are much better if you are in a major city, but this is slowly changing.

In some locations, it's easier to get a connection across the continent than across town, and a leased ISDN going 40 miles from city to suburb can occasionally cost more than the long-distance link. In other parts of the country, local links are available, but long distance is not.

Shopping for ISDN

The CCITT organization is in charge of defining ISDN standards, which include more than just digital communications. ISDN1 is an evolving American standard developed by Bellcore that describes the digital switches. ISDN also determines the signaling methods in the lower three layers of the ISO model (as defined in the last chapter), the physical, data link, and network layers. ISDN services can be built on these communications layers as well. The *IS*—for integrated services—in *ISDN* refers to a group of network services and applications developed by vendors. Apple envisions ISDN services and applications to be integrated screen-based telephone and data programs that use voice, data, graphics, and video. Apple, Hayes, and Farallon, among others, have demonstrated some of these applications in public, but few off-the-shelf products exist at this time.

Several types of ISDN service are offered, including the basic rate interface service and the primary rate interface service. Basic rate service has a total bandwidth of 144 Kbits per second; the primary rate has a total bandwidth of 1.54 Mbits per second in North America and Japan and 2.048 Mbits per second in Europe. Each type of service is made up of multiple separate channels that, when used, still allow the transmission of information on another channel. Although Figure 13.9 represents the channels as separate wires, the channels are really separate paths on the same wire. Having separate channels also enables you to dedicate, and therefore guarantee, bandwidth for a particular purpose.

There are two types of channels used in ISDN, the B (Bearer) channel, which provides transfer rates of 64,000 bits per second (bps), and the D (Delta) channel, which provides signal rates at either 16,000 (basic) or 64,000 (primary) bps. The B channels are where the user communications are transmitted. Multiple B channels can be used for simultaneous digital voice calls, or simultaneous data calls, or used for both voice and data calls. B channels can be used for circuit-switched or packet-switched connections, such as SW56 and X.25.

The D channel is used for the signaling information required by the B channels. A significant feature of ISDN is that this signaling information—the call setup, dialing, ringing, busy signal, etc.—is sent on a separate channel from the user data. This is called out-of-band signaling. When you open a modem connection or place a phone call over today's analog telephone system, the signaling is sent in-band, which locks up the entire line during the

signaling process. Since signaling does not occur all the time, the D channel can also be used for X.25 packet switching or other low-speed transport.

Figure 13.9

Basic rate ISDN offers 3 channels; primary rate offers 23 channels in North America and 31 in Europe.

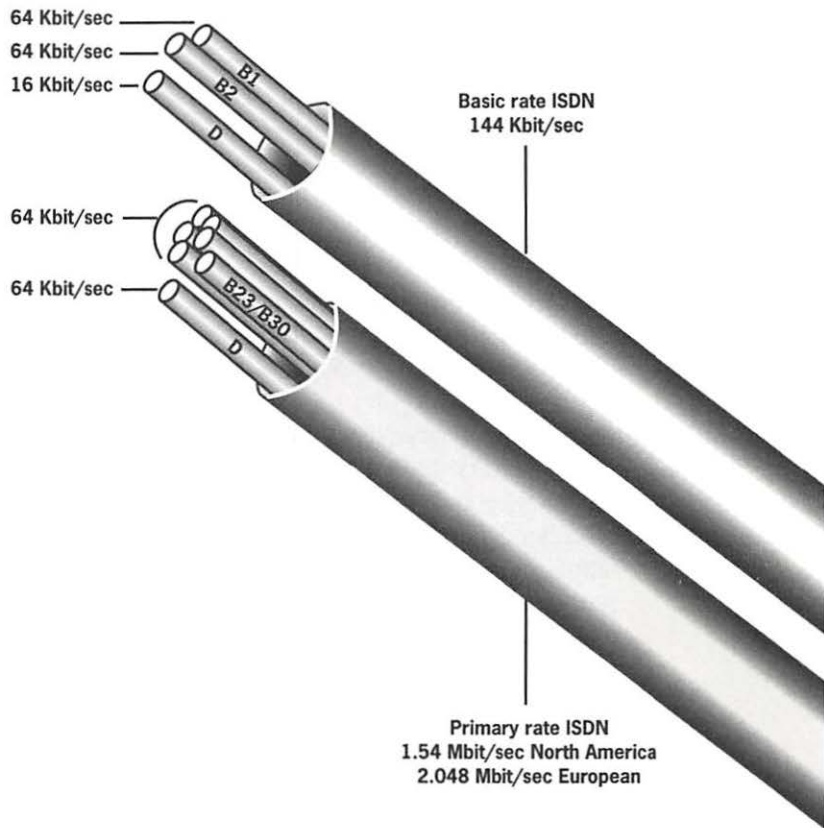

Basic rate ISDN consists of two 64,000 bps B channels and one 16,000 bps D channel for a total bandwidth of 144 Kbits per second. Primary rate ISDN consists of one 64,000 bps D channel and 23 B channels in North America and Japan, and 30 B channels in Europe.

ISDN costs are a fraction of the costs of T1 lines. Monthly ISDN rates in Northern California and New England in 1992 ranged from \$15 to \$30 per month, plus a usage charge, the same as with current telephone service. There is also a one-time connection charge of several hundred dollars. Private ISDN lines are also available at higher costs. ISDN's low price has to do with the basic economic fact that cost goes down when volume goes up. And

there's a great deal of volume involved with the public telephone system, the biggest communications network in the world.

Remember, the cost of ISDN includes integrated voice service. Because voice traffic is digital, an ISDN voice connection produces better sound quality than an analog telephone connection. A digital voice connection carries far less noise than an analog connection; the noise you currently hear on telephone connections is mostly generated by the local analog portion of the telephone company's lines. ISDN is so quiet that early providers of the service introduced noise intentionally because users thought the connection was dead when they didn't hear noise.

Connecting Macs to ISDN

ISDN can run on existing twisted-pair network cabling. Individual Macs can connect to an ISDN line using an interface card. A digital telephone can connect to the same line by plugging into the interface card as well. The Apple ISDN NB Card comes with the software needed to make a connection and with an external power supply. Individual ISDN cards will most likely remain at a cost of over \$1,000 for several years, until ISDN becomes a mass-market item like Ethernet cards.

A more cost-effective method is to connect a network full of Macs to ISDN. Many WAN routers now support ISDN. An AppleTalk WAN router, such as Transware's TransTalk, may be used with an external ISDN adapter, such as the Hayes ISDN System Adapter. However, this type of solution is slower than using individual ISDN cards.

On the software side, a Mac application can access ISDN through the Communications Toolbox, which uses an extension file called the Telephone Manager. The Telephone Manager is an application program interface that provides a set of telephone functions that could allow applications to share telephone-related data via Apple events and integrate voice into applications. For instance, a database application could dial a phone number, play a recording of a voice, and record a response. Other types of applications include Mac-based personal voice mail, travel services, and video conferencing.

Waiting for ISDN

ISDN has been demonstrated so many times at trade shows and industry events that people are questioning the reality of the service. People are saying, "So, where is it?" The answer: in the hands of the telephone companies that will deliver the service. The technology on the Mac end is there. Apple, Hayes, Farallon, and other vendors have announced or are shipping ISDN products, and other companies have ISDN services waiting in the wings. Part of the problem has to do with expectations; the telephone industry moves

gradually to change technology, and the computer industry adopts the latest technological advances even before they're useful.

Compared to the switch from rotary phones to pulse tone, which took almost 20 years to complete, the rebuilding of the public telephone network to support ISDN has been, and continues to be, a big undertaking for the phone system. Compatibility with the existing system is an absolute requirement. With the ISDN1 specification not solidified, the digital switches used in the telephone exchanges are not yet completely compatible among different brands. Compatibility with other countries is another thorny issue.

The first lines to go digital were the long-distance connections, so there are more of them available than there are local ISDN connections. Local ISDN connections outside of major cities have been difficult and expensive, sometimes more expensive than the long-distance lines. As of 1991, 100,000 long-distance lines were installed in the United States. At the same time, only 37 of Pacific Bell's 700 Northern California wire centers were equipped to handle ISDN.

How the telephone industry approaches the ISDN market also affects when developers in the computer industry jump on the ISDN bandwagon. The phone companies are first making ISDN available to the same customers they sell T1 lines to: big corporations with six-figure monthly telephone bills. The PC industry, which was first driven by small business, wants ISDN widely available to small businesses and homes. If you call your local baby Bell to inquire about ISDN service to your house, chances are that the people you speak to will not know what you are talking about.

The home market is important not as a consumer market, but as a targeted market of influential telecommuters. The telephone industry is slowly coming around to this viewpoint as well, but it will be a few years until home ISDN service will become widely available. However, I do believe that ISDN will become the long-distance voice and data standard before the end of the decade. Not only has the investment by the phone companies been in the billions of dollars, but the cost of the service to users is just too low and the benefits too high for ISDN not to succeed.

■ **Dueling Protocols: OSI versus TCP/IP**

In the United States, TCP/IP has become the de facto network protocol standard for networking large numbers of computers of different types over long distances. Other parts of the world look to a newer protocol set for wide-area networking, the Open Systems Interconnection (OSI) published by the International Standards Organization (ISO) as a standard wide-area network (that's right, the ISO OSI). This is not to say that TCP/IP isn't used in Europe and Asia, but for mainstream business, OSI is the favorite.

The contest between TCP/IP and OSI is reminiscent of the one between the English and metric systems of measurements. TCP/IP, like English, is an older system that evolved out of necessity. Like the metric system, OSI was designed from the start by a standards committee, and has been adopted in Europe.

As with the English/metric battle, there was a time not too long ago when it looked like OSI in the United States was inevitable. In the late 1980s, corporate America began tying their diverse PC and Mac networks together with mainframes on their internet backbones. At that time, it was common for network managers to speak of holding off implementing TCP/IP across their internets, or installing TCP/IP as a temporary measure, with the expectation that they would switch to OSI in the near future. Corporate MIS departments were reluctant to adopt TCP/IP for several reasons, one of which was its relation to the TCP/IP Internet, which had a reputation for being populated by mischievous hackers. OSI, on the other hand, was well respected; other network protocols, such as AppleTalk and DECnet, were actually designed along the lines of the OSI model, as discussed in Chapter 12.

The problem was that OSI products never materialized in quantity in the United States. TCP/IP, though not as elegant, worked and was widely supported and gained in popularity. However, some people in the industry still think that the United States will eventually come around to OSI.

The biggest advantage of OSI is that its services are better than the rudimentary services of TCP/IP, which were developed almost two decades ago for use by programmers, not office workers. For instance, although TCP/IP's simple mail transfer protocol (SMTP) facilitates simple text messaging, OSI's X.400 supports a full suite of modern electronic mail features. In addition, although the TCP/IP services are based around UNIX, many of the OSI services were designed with multiple operating systems in mind. Fortunately, many pieces of the OSI protocol stack are being used on other network systems.

For the Mac, Apple offers implementations of various OSI-related protocols and services, such as X.25 and X.400. Apple also offers the OSI transport itself, useful for maintaining WAN connectivity with overseas computer installations. Mac ODA (described later on) supplies data translation for the open document architecture formats.

X.25 Packet Switching

CCITT X.25 actually predates OSI, but is heavily used in OSI environments, as well as in some non-OSI environments. X.25 is a wide-area network data link protocol that can be used over a variety of transport media, such as land lines, satellite, ISDN, and modem links. X.25 is used by a fair number of American mainframe companies, including IBM, which offer it under SNA.

Several on-line services such as CompuServe use X.25. Companies such as Telenet, GEIS, and Tymnet offer modem access to public packet-switched networks for use in creating wide-area networks.

X.25 uses a technique called packet-switching, which is similar to multiplexing: Signals from several sources are intermixed to make full use of the transmission medium's bandwidth. Packet-switching intermingles packets, whereas multiplexers use various frequency or amplitude modulation techniques. In X.25, a piece of software called a packet assembler/disassembler (PAD) creates packets on the computer and sends them out on the network.

Apple's MacX25 software is an X.25 server that runs on a Mac with a serial NB card. The server can operate at 19.2 Kbits per second with an RS-232 interface, or at 64 Kbits per second with a V.35 interface. Client Macs connected to the X.25 on an AppleTalk network create X.25 packets with MacPAD, an implementation of an X.25 PAD as a Communications Toolbox connection tool. This allows terminal emulators supporting the Toolbox to make host connections using X.25.

MacX25 comes with an administration application to set up users and passwords. It also enables setup of host connections (see Figure 13.10). MacPAD users get a list of host and service names, and don't need to know address numbers or PAD commands.

Figure 13.10

The MacX25 administration program lets you set up host addresses so that users get a list of host names from which to choose.

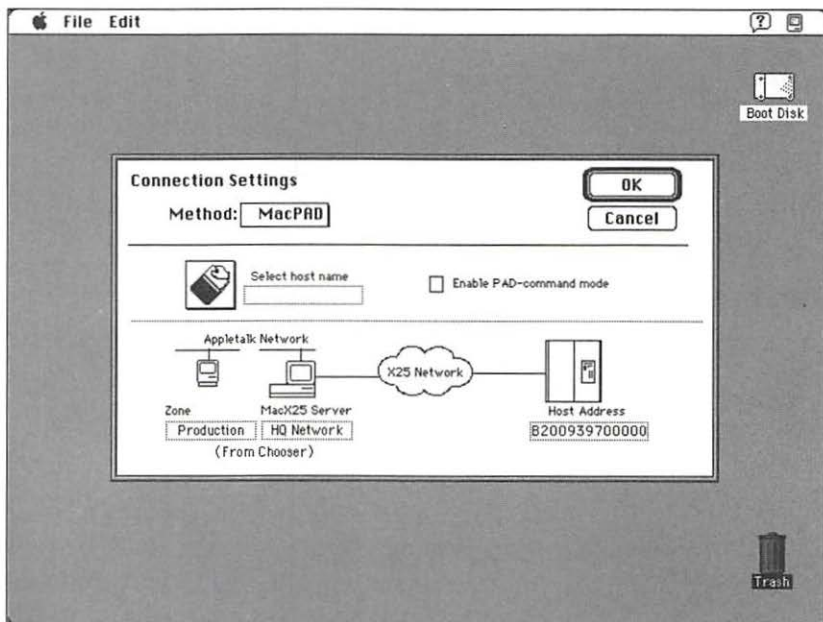

MacOSI Transport

Apple's MacOSI Transport provides Macs with the ability to run the core of the OSI protocol, allowing multiplatform computer-to-computer connections. MacOSI Transport provides an individual Mac with layers 1 through 4 of the OSI network protocol model. MacOSI Transport can be run over Ethernet on a local area network, or can be used with MacX25 for wide-area networking. MacOSI Transport is compatible with several types of OSI routers.

Applications can use MacOSI Transport through a Communications Toolbox connection tool or through the industry standard X/OPEN Transport Interface (XTI). This means that Mac applications can communicate with XTI applications over the network.

MacOSI Transport is a well-written driver, and network throughput is good enough for sending video between two machines. Apple claims they have reached a 6.4 Mbit-per-second sustained throughput over Ethernet.

To install MacOSI Transport, a user adds a control panel file and the connection tool file to the System Folder, and enters a local OSI address in a control panel. Other parameters are preconfigured, but can be altered. The transport is similar to AppleTalk's ASDP, which is also available to applications through the Communications ToolBox. MacOSI Transport requires System 7.0 or later.

X.400 Mail

CCITT X.400 is the OSI electronic mail/messaging standard designed to be a global messaging system, working on a variety of computers over wide-area networks. X.400 messages are passed from server to server through the use of a piece of software called message transfer agent (MTA). The biggest U.S. supporter of X.400 is Digital Equipment Corporation, which has used X.400 as the basis for its VAX VMS based All-in-1 mail system. Other host manufacturers use X.400 messaging as well. As I discussed in Chapter 9, both Digital and Alisa offer VAX-based X.400 solutions for Macintosh clients.

Apple's MacX.400 is an MTA for the Mac that turns a Mac into an X.400 electronic mail server for a whole AppleTalk network of Macs. It will also route X.400 messages to non-Mac mail recipients. The server itself runs on an OSI network, so that it can communicate with other X.400 servers running on VAXes and other computers. MacX.400 runs on Ethernet on a LAN and works with MacX25 for wide-area networking. The server software can share a Mac with other networking applications. Configuring the server using the administration application is a fairly straightforward procedure (see Figure 13.11).

Figure 13.11

Apple's MacX.400 server provides Macs on AppleTalk networks with an inexpensive connection to mail servers on OSI wide-area networks. Shown here is the user-friendly administration program.

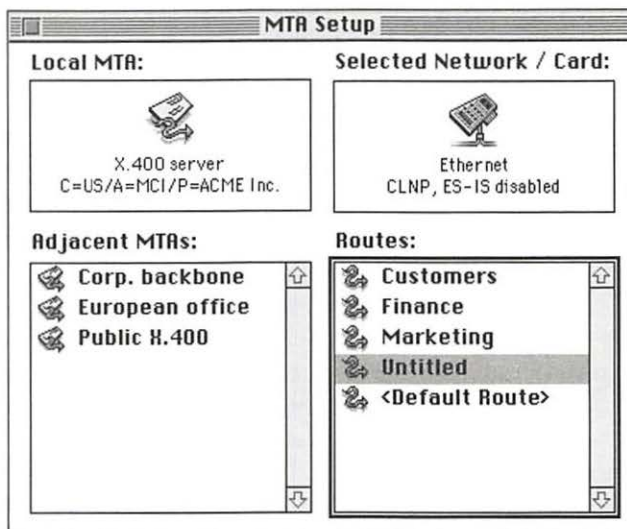

Client Macs have two options for accessing the server: running native X.400 client software on the Mac, or accessing a network gateway to a Mac mail program such as Microsoft Mail or QuickMail. In fact, the combination of X.400 and gateways can be seen as a solution to connecting Mac, PC, and host mail systems. X.400 gateways to Mac mail packages are available from Intercon and Star 9.

Open Document Architecture

In addition to passing around mail messages to different types of computers, OSI also has a standard document-content format that facilitates passing around files that can be read on various machines by different applications. The Open Document Architecture (ODA) is a document interchange format that is designed to transfer complex text-formatting information, such as columns, boldface and italic type, multiple fonts and sizes, headers, footers, and footnotes. ODA documents can also contain bit-mapped and vector graphics. Because it is a universal format, ODA is often used to archive files.

Macs can save documents in ODA format with Apple's MacODA. MacODA is a translator that works with XTND-aware Mac applications, such as Claris's MacWrite II and ClarisWorks, Nisus Compact, WordPerfect, and Symantec's GreatWorks, among others. Users just drop the MacODA translator in an XTND folder, and the ODA format appears in the Save As

dialog box. (See Chapter 2 for a more detailed explanation of the XTND technology.) MacODA works over any type of transfer medium, as well as OSI and TCP/IP networks. MacX.400 supports ODA enclosures.

ODA is much more popular in Europe than in the United States, but some U.S. vendors support it. With MacODA, XTND-compatible Mac applications can join a multiplatform document-reading environment. For instance, Xerox GlobalView is an ODA converter that runs on the SUN SPARC UNIX workstation. Digital has an ODA gateway to its Compound Document Architecture (CDA) format that converts DECwrite files to ODA. There are also converters for Microsoft's RTF format on Windows, and several multiuser databases support ODA as well.

■ Looking Ahead

During the course of this book so far, I've moved from discussions of some of the easiest, oldest connectivity technology to multiplatform wide-area networking and enterprise computing, the last two of which are perhaps the last frontiers of connectivity. AppleTalk routing over WANs has only recently become practical on a large scale, and the promise of wireless networking, ISDN, and other new technologies now dangles before our eyes. Yet, the solutions are bringing on yet more problems to solve. For instance, how do we navigate through networks of thousands of computers without getting lost? What do we do with all the data we can now connect to? In the next chapter, I'll explore how Apple will be addressing some of these issues with new Mac operating system capabilities designed to move us beyond thinking about how to connect to thinking about how to collaborate.

- *Getting to the Core of OCE*
 - *Using OCE Directories*
 - *Using Mail and Messaging*
 - *Employing Security*
 - *Looking Ahead to OCE Applications*
-

C H A P T E R

14

Collaboration, the Next Step



COMPUTER TECHNOLOGY EVOLVES RAPIDLY, BUILDING ON what has come before and quickly moving beyond. Rarely does any state-of-the-art hardware or software remain in the top position for more than 18 months without a major upgrade. Throughout this book I've tried to give you a taste of some of the advancements in connectivity that you can expect to see in the near future—wireless networks, FDDI, ISDN, and distributed processing, for instance. Now I'd like to turn back to the Mac, and look ahead to some promising new capabilities Apple is building into the Mac operating system.

Apple is looking beyond connectivity to *collaborative computing*, the interaction between people, applications, and network services which results in the automatic flow of work throughout the organization. In some organizations, much of the interactions between coworkers is already occurring through computers. However, there are aspects of the way the dozens of connectivity options discussed in this book are all hooked together that hinder collaboration. For one, adding a new connectivity feature to a network system is often a complex and expensive proposition. Further, users are being required to absorb more and more technological knowledge. Gateways to multiple networks and multiple network services have given users several types of programs to learn and multiple network user IDs to remember. With a LAN e-mail system, MCI mail, America Online, and a few different file servers, a user could easily have six or seven different addresses on a network.

Apple's *Open Collaboration Environment* (OCE) is a set of additions to System 7 that will offer users a way to consolidate all of their interpersonal application communications methods into a consistent, easy-to-manage environment. The impact of OCE on Mac connectivity and collaboration should be as great as the introduction of the LaserWriter and AppleShare. More than just an interface, OCE is an operating system framework that provides a new set of store-and-forward services available to both users and OCE-compatible applications. These services will provide directory consolidation, mail and messaging, authentication/privacy, and a new type of security technology called the digital signature.

The OCE framework that provides these services is extensible and modular. The word *Open* in OCE means that any developer is being given tools that will give them access to the features of OCE to make their applications OCE-aware. In fact, third-party products will be the source of many of the exciting uses of OCE. For the user, extensibility and modularity mean the ability to add a new capability by dropping a file in the System Folder.

Unlike proprietary connectivity solutions, the OCE services will be accessible from within applications and within the Finder, reducing to one the number of interface techniques a user is required to learn. The user will experience OCE as an extension to the Finder, with its metaphor of folders and files. OCE retains the basic techniques of the desktop—clicking and dragging and double-clicking of icons.

In the past, Apple added new capabilities to the Mac by saving up a group of new features and including them in a new version of the System and Finder. The problem with this approach was that the delay in the development of one or more new features caused a delay of the entire System release—System 7 shipped about 18 months later than Apple originally had hoped. Apple's current strategy for new System features such as the Open Collaboration Environment is to release each new feature separately as an

extension file as soon as it is ready. Eventually, OCE client software will be incorporated into a version of System 7.

■ Getting to the Core of OCE

At the heart of OCE are the five core services: directory, mail/messaging, authentication, privacy, and digital signatures. All are store-and-forward services, meaning that a recipient Mac doesn't have to be on-line when a message is sent: The message will be held by the local Mac or an OCE server until the recipient Mac is back on-line.

The core OCE services are more than network services, such as file serving and traditional electronic mail implementations. Although OCE will work over AppleTalk, OCE is not a set of network protocols, and is not dependent on any network. The OCE services will work over non-network telephone connections and serial links as well as over networks.

Since users access OCE through OCE-compatible applications (including the Finder), the applications are called the front end of OCE (see Figure 14.1). At the back end are *service access modules*, System 7 extension files that sit in the System Folder of the user or of an OCE server. Service access modules will be provided by Apple and by third-party vendors. OCE-enabled applications can communicate to any technology that has a service access module available. Using service access modules, organizations can integrate in-house communications software, directories, as well as proprietary authentication schemes for interpretability with OCE. This open and modular architecture allows for some very interesting potential uses of OCE, as will be discussed later in this chapter. But first, let's take a look at the core OCE services.

Directory Services

With the proliferation of network services, there has been a proliferation of directories. File servers and electronic mail systems each have their own lists of users. Add to that the directories of network resources that I've described in previous chapters—the Chooser with its list of AppleTalk resources, and Novell, Banyan, and Digital with theirs, each with different naming conventions. Gateways allow connectivity between these systems, but unless you know the exact address name and path of a user or service, accessing them can be a challenge. The problem is amplified when users join wide-area networks and are faced with hundreds of addresses, some of which are on foreign networks that employ obtuse numbering schemes for node and mail addresses.

Figure 14.1

The core services of OCE are directories, mail/messaging, and security, all available to OCE-compatible applications, which can link to network software using files called service access modules.

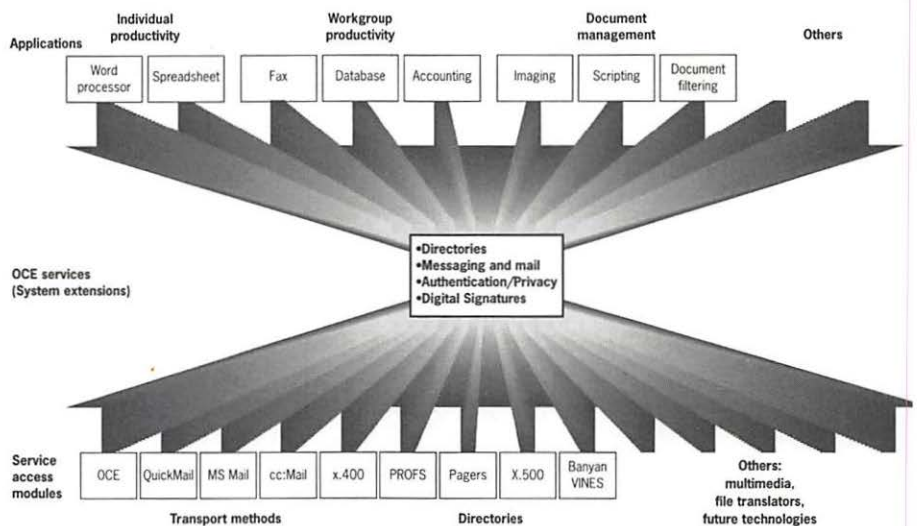

The X.500 directory standard attempts to address the problem of multiple directories by proposing a single, synchronized directory service for all network services. X.500 would resolve differences in naming and eliminate duplications. Although X.500 is a good idea that has support in the industry, it would take years before a majority of network applications would support it. Even so, it is likely that many connectivity systems won't adopt it.

As an alternative to waiting for a single synchronized directory to come along, the Open Collaboration Environment will offer a practical solution. The OCE directory service enables multiple directories, all based on different technologies, to appear in a single place with a single user interface.

OCE directories are hierarchical containers of information about entities, and have the capability to include documents or even pieces of software code, in addition to names of users and groups. A directory can also contain data that will be used by shared applications. You can also add your own information to a record in a directory, as you would in a database.

OCE's Directory Browser is a mechanism within OCE that adds a new volume on the desktop to allow users to view either personal directories, native shared directories, or external directories from various sources, such as an in-house mainframe or public service directory located on a network. A personal directory, called a Personal Address Book in OCE lingo, is one that you create and store on your Mac to keep your most frequently used addresses for users on LANs, WANs, and on-line services, as well as fax and

phone numbers, and other communications link information. Native shared directories include a list of AppleTalk zones, printers, and other services that are now accessible through the Chooser, as well as a server-based OCE directory server, which will be sold by Apple and third-party vendors. You can also access directories that are foreign and external, such as X.500 directories or user lists for PC-based network operating systems such as Banyan's StreetTalk. OCE's Directory Browser enables you to double-click on the directories and directory entries contained within the new directory volume just as you now double-click on folders and files to see their contents.

Mail/Messaging Services

Messaging is usually used to describe communications between applications; *mail* indicates user-initiated actions, and is a subset of messaging. Like directory services, the OCE mail and messaging services also get a new desktop Finder volume, called *the Mailbox*, where you'll be able to receive any and all electronic mail, as well as other types of messages, including messages generated from QuickMail, X.400-based mail messages from PCs or VAXes, messages from on-line services such as AppleLink and CompuServe, faxes, QuickTime movies—even telephone voice mail. You'll need a service access module for each type of message you want to receive.

You'll also be able to send messages from within any OCE-compliant application, including word processors, graphics programs, and spreadsheets. Developers can add a feature called the *OCE Mailer*, an electronic mail form that can appear in a separate window or right at the top of the application window itself.

It is important to note that OCE will not replace electronic mail systems, but creates a new framework that will enable electronic mail (as well as other technologies) to connect to everything else you are doing on a Mac. You will still be able to use an OCE-compatible electronic mail package such as QuickMail as a front end or a back end. As a front end, a mail package would act as a full-featured communications application from which you could send mail messages; you would use OCE to move the files around. As a back end, you could use a third-party mail server to move messages around, possibly improving performance, while using one or more OCE-compatible applications as the front end. Since all the major electronic mail vendors will have OCE-compatible versions of their products, you could choose to use the front end of an OCE-compatible QuickMail with the engine of an OCE-compatible Microsoft Mail, or the engine of OCE with the front end of an OCE-compatible cc:Mail.

Authentication and Privacy Services

OCE authentication services allow users to send secure documents and information electronically. Before a message is sent over a network, authentication ensures each party's identity through the use of an authentication server. This prevents the possibility of masquerading users on the network. Once the authentication server has given the okay, privacy is then created during the transmission with encryption to prevent against wiretap loss. Since the recipient has been verified, a message can be automatically decrypted upon arrival. OCE encryption automatically codes and decodes information being sent over a network.

Digital Signature Services

A digital signature is like a wax seal that you apply to a document. It ensures trust in electronically transmitted documents by detecting if a message has been altered, either intentionally, through an error in transmission, or by a virus. If, upon receiving a file or message, the digital signature services software on your Mac detects that the message has been altered, you will receive a message informing you that your message has been tampered with. The digital signature feature can add confidence to collaborative uses of networks such as electronic routing of documents.

■ Using OCE Directories

Directories can contain other directories or data, often referred to as directory entries or records. The interface features provided by the Directory Browser to access this data will seem familiar to any Macintosh user. Basically, directories and directory data are manipulated the way you now handle files and folders. Because the OCE directory service is implemented at the operating system level, you can use the mouse to drag and drop directories and directory entries between the Finder and applications. There are also several ways to get inside directories to view the directory data.

Directories in the Finder

To create a new personal directory, you choose New Distribution List from a menu in the Finder or an application. A new Personal Address Book will appear in the Directory icon on the desktop. You can create a new directory record for a personal directory by choosing New User from the same menu. You can also copy records from other directories by clicking and dragging, just as you now copy files between mounted volumes.

As with volume icons in the Finder, the Directory icon (as well as the Mailbox) is hierarchical. When you double-click on the Directory icon, you'll

see several directory file icons, including one representing the personal directory you have created, an AppleTalk directory, and any other directories on the network for which you have a service access module installed. You can also view the directories as a hierarchical tree, as with ordinary files in the Name view of System 7. You can view any directory by double-clicking on one of these directory files.

When you double-click on a directory entry in the directory volume, a window comes up displaying a *template*, which gives you a view of one record. You can add new templates written by developers by dropping a file in the System Folder. A template does not have to display all the information contained in a record, but can show you a portion of the information contained in the record. For instance, an organization could distribute a template for a directory that displays a user's telephone number, department, and job title. The same directory may also contain additional information, such as an internet address, CompuServe address, and Ethernet node number, which could be viewed using another template. Initially, users won't be able to make their own templates, but you can expect to see a lot of them from third-party developers.

You'll be able to copy directory items from directory templates into connectivity applications such as mail programs so that a message could be addressed with a drag and drop. You'll also be able to drag a telephone number onto the icon of an OCE-compatible communications program to dial that number. A directory item can also be dragged from one directory to another. You can also put directories in the Apple menu for easy access by dropping an alias of a directory into the Apple Menu Items folder in the System Folder.

An alternative way to view lists of directories and directory entries is to drag them to the desktop and drop them. When you drag and drop a directory to the desktop, a file is created called a Distribution List. You double-click on this stand-alone file and view the entries just as you can in the Directory icon.

When you drag and drop an individual directory entry onto the desktop, it becomes a file called an Electronic Business Card (see Figure 14.2). Like templates, Electronic Business Cards are viewers into an individual record.

However, these stand-alone versions of the Directory Browser are not mere databases, but have some very useful interface characteristics. Both Distribution Lists and Electronic Business Cards can be dragged into OCE-compatible applications for addressing messages, or can be mailed as an enclosure. If you drag and drop a file on top of a Distribution List or an Electronic Business Card, a copy of the file will automatically be sent over the network to the addresses or address in the List or Card.

Figure 14.2

When a directory is dragged to the desktop, it becomes a Distribution List. When a record is dragged from a directory to the desktop, it becomes an Electronic Business Card.

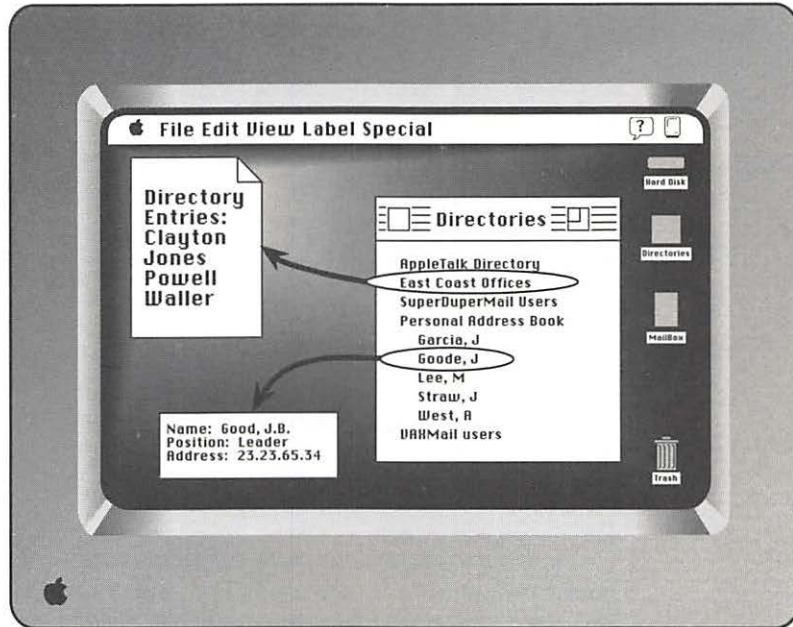

In addition to enabling you to access directories from the Finder, OCE has an API (application program interface) that enables application developers to include a pop-up menu that lists the records in a directory. When you click on the appropriate field of the Mailer portion of an application, a panel pops up with a list of records. You can then select one or more directory records to address a message from within the application. Click outside of the panel, and the menu disappears. This pop-up menu is non-modal, so you can leave it open while you are working in other windows. OCE-compatible applications can also view the list of directory records from a directory browser window much like the current Open dialog box. However, applications can't display the data inside of a record, as you can with templates in the Finder.

OCE and AppleTalk

With dozens of zones and devices to scroll through and no method of doing a search, the Chooser on a large network becomes inefficient as a tool for selecting network devices. On big wide-area networks, the Chooser becomes virtually useless. Fortunately, OCE's Directory icon includes an AppleTalk directory, which lists AppleTalk zones, and eventually will list network devices.

The Finder-like tree structure that directories will use to display zones and devices is a much easier method for viewing large networks than the Chooser. In later releases, the OCE-compatible Finder will include a tool to help you locate directory entries.

It is also possible that OCE will eventually replace the Communications Toolbox (discussed in Chapter 9). Application developers could supply service access modules instead of Communications Toolbox tools to make various types of connections to their applications. Other upcoming system enhancements from Apple will allow you to create icons on your desktop that represent printers. Choosing a printer and printing a file will be accomplished by dragging and dropping your file onto the printer icon.

The AppleTalk directory can reside either on a server or be distributed across the network. In the case of a distributed serverless network, each Mac requires a special serverless service access module to enable the Mac-to-Mac sharing of directory information. OCE uses an extended version of the ADSP protocol (see Chapter 12) to establish point-to-point links between Macs on AppleTalk. However, this and other OCE protocols are not AppleTalk protocols—they can function over non-network links as well as over AppleTalk and other networks.

Apple will offer an OCE server for AppleTalk that will run on a Mac. The OCE server will offer directory service and authentication, and possible other OCE services. Apple's OCE directory service provides an automatic directory replication and synchronization system to keep all OCE-based directories synchronized to avoid having outdated material on one server and fresh data on another. OCE servers are also time synchronized to ensure that all directory changes are updated with the latest entry. OCE administrators will have the ability to remotely administer OCE servers from any Macintosh on the network.

Apple is not dictating how a directory server should work, so there won't be an OCE equivalent of AFP. Apple has stated that it expects to see other competing directory servers on the market. Novell has announced an OCE-compatible directory server, called the Global Messaging Server, which runs on Netware 3.11. Intended mainly for Message Handling Service (MHS)-based mail programs, the Global Messaging Server will show up in users' directory volumes.

■ Using Mail and Messaging

The directory feature of OCE would have had a big effect on the electronic mail market were it the only service included in the new system software, but the built-in mail features of OCE will completely change electronic mail for the Mac. For one, an electronic mail server will no longer be required. Just as

System 7's File Sharing offers distributed file serving, the built-in mail engine of OCE can work as a distributed store-and-forward mail system. In addition, Apple is introducing baseline electronic mail features that third-party electronic mail packages must include in order to stay competitive. Another big change will be that addressing messages to users on different mail systems will become greatly simplified, no longer requiring special knowledge of multiple e-mail systems. As with the OCE directories interface features, the Mailbox on the desktop and the OCE Mailer in applications offer some very flexible and powerful capabilities.

The Mailbox

As a common place for messages of all kinds to arrive, Mailbox volume on the desktop is quite convenient. For instance, if you subscribe to one or more on-line services, you no longer have to remember to log on every day to check for mail; messages will arrive in the Mailbox automatically. The OCE service access modules installed in your System Folder or that of an OCE server act as gateways to various communications systems.

Using the Mailbox volume is as easy as using a normal desktop volume. Messages can be moved to folders on other volumes or read right from the Mailbox. To read, watch, or listen to a message in the Mailbox, you double-click on the message icon. Once a message is open, any enclosed files can be read without having to first download them to your hard disk. Double-clicking on an enclosed item launches the appropriate application and opens the file over the network. If you don't have an application that can read the file format of the document, OCE will be able to make use of XTND file translators (discussed in Chapter 2) to translate the document to a format you can read. To download an enclosed file, just drag and drop the file from the Attachments field to the desktop or any volume or folder. The desktop Mailbox also provides message management functions such as archiving, sorting, retrieval, and forwarding of messages.

The Mailer

The OCE Mailer is a standard electronic mail form that can appear right in the window of an open document if the developer chooses to implement it. The OCE Mailer can be turned on and off from within an application. To add a Mailer to a document, select Add Mailer from the Mail menu of an OCE-compatible application. When a Mailer is added to a document, the document becomes a new type of file called a letter. Selecting the Save command creates a new letter icon in the Finder. You can remove a Mailer from a document by going to the Mail menu and selecting Remove Mailer.

When a Mailer is added, a small icon will appear in the upper-left of the window bar to indicate that the file contains a Mailer. Clicking on the triangle opens the Mailer, which takes up the top third or so of the document window. You could use the Mailer to send someone the document you are working on from within the application (see Figure 14.3). This means that you could use a word processor or spreadsheet program as the electronic mail front end. You could take a complicated spreadsheet, add a line of text that says “Here are the Kleinman calculations” in the Mailer message field, and mail it.

Figure 14.3

The Mailer can appear as an electronic mail form right within the document window of an OCE-compatible application. Files can be enclosed by dragging them from the Finder.

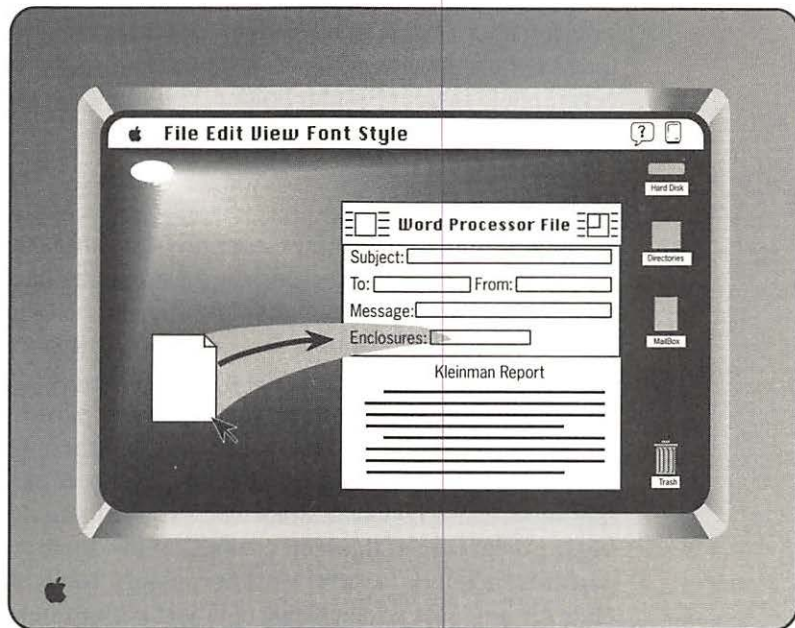

There is a second type of OCE mail interface that application developers can choose to implement. This is a small, separate window that is not associated with any particular document. When a developer has implemented this mail window in its application, a small envelope icon will appear in the lower-left corner of the file window instead of the icon mentioned above.

Both OCE Mailer interfaces contain five fields: From, Address, Regarding, Attachments, and the message field. Double-clicking in the Address field brings up an OCE personal directory, or any other OCE directory you choose. The recipient could be on any mail system for which you have service access module files. You can also drag and drop an address from a directory

template in the Finder. To enclose a file, you can simply drag a file from the Finder to the Attachments field. Addresses can be obtained from a directory through the use of a dialog box or dragged from the Finder and dropped into the Address field.

The Send command brings up a dialog box that lets you set the message priority. There is also a check box for adding a digital signature, a security feature that I'll discuss a little later. You'll also have a choice of sending any enclosed files in document or image format. Document format is the application's native file format, which is how today's e-mail software sends files. An image format is like a fax: The recipient can read it, but it is not editable text. This is a good choice for recipients who don't have the application you are using. (Recipients using OCE can use XTND translators with the Mailbox.) You can also use the image format to send actual faxes from the Mailer, as long as your Mac has access to a fax modem, and you have a fax service access module in your System Folder. You can also send graphics, sound, and QuickTime movies from within an application.

Messaging

Messaging under OCE brings store-and-forward technology to System 7's Apple events, so that commands and data can be passed between applications on different computers that aren't running at the same time. The computers don't even have to be on the same network: The store-and-forward messaging engine can activate a transaction when a telephone link is established.

Messaging can be used for unattended application collaboration that occurs in the background. This can be accomplished through the use of software entities known as *agents*. Agents are clients of the messaging service, in that they react to messages received and facilitate the sending of other messages. Agents are authorized by applications to do your bidding in other parts of a network to move workflow along. You'll be able to use agents to reduce the amounts of electronic data you get by filtering the data; you'll also be able to use agents to manipulate databases.

You'll be able to develop your own software agents using scripting languages such as UserLand's Frontier or Apple's future AppleScript, another new capability that Apple is adding as an extension to the System. On one level, AppleScript gives Mac users the ability to write batch commands for simple activities, such as copying a group of files containing certain common characters—a capability PC users have always had with DOS. However, AppleScript will also act as a user front end to Apple events and messaging. AppleScript will at first work with the Finder, and later with applications, as developers revise them to be AppleScript-enabled.

■ Employing Security

The last three OCE services all deal with some aspect of security. Although terms like security and encryption bring to mind visions of spies, troop movements, and secret rocket fuel formulas, there is a need for protection of data in an office environment. This need has to do with your company's competition, with protecting people's privacy, and with trust in the reliability of documents. The moving of electronic files over a network presents a potential security risk: The bits of data are broadcast everywhere, and you can't tell if your file has been tampered with.

OCE's security services go beyond simple password protection to include some of the newest encryption techniques to ensure piece of mind without changing the way people work. OCE security offers new confidence that the data you send won't be tampered with or read by unauthorized snoopers.

The three security services provided with OCE, authentication, privacy (encryption), and trusted documents (digital signatures), are based on technology licensed from RSA Data Security, Inc. The technology is called RSA public key encryption (named after its inventors, Ronald Rivest, Adi Shamir, and Len Adleman). RSA technology was invented in the late 1970s but has recently started to become a de facto industry standard, with licensees including Lotus, Microsoft, Digital Equipment Corporation, Novell, and Sun, as well as Apple.

Authentication and Encryption

One problem with passing information over a large network is making sure that the person receiving the data is the person you intend it to be. Password protection has several problems. If unauthorized people get a hold of a password, they can pretend to be someone they're not. With password protection, you also have to tell the recipient the password. This means you have to trust them before you send the document, which is not always possible if you don't know the recipient, or the person who claims to be the recipient.

For information being transmitted over a network or telephone line, OCE adds several additional security schemes to any password protection already used by software. OCE uses an authentication server running on a Mac to ensure the authentic identity of each party involved in a network transaction (see Figure 14.4). Authentication can occur automatically when you sign on to an OCE/authentication server. If you are going to send a file or a mail message, your Mac will ask the server for a credential that verifies the identity of you and the recipient. Using the information from the server, the two Macs then perform a credential handshake. If the handshake fails, the message won't be sent.

Figure 14.4

OCE authentication performs a credential handshake with an authentication server to ensure that two parties on a network are who they say they are.

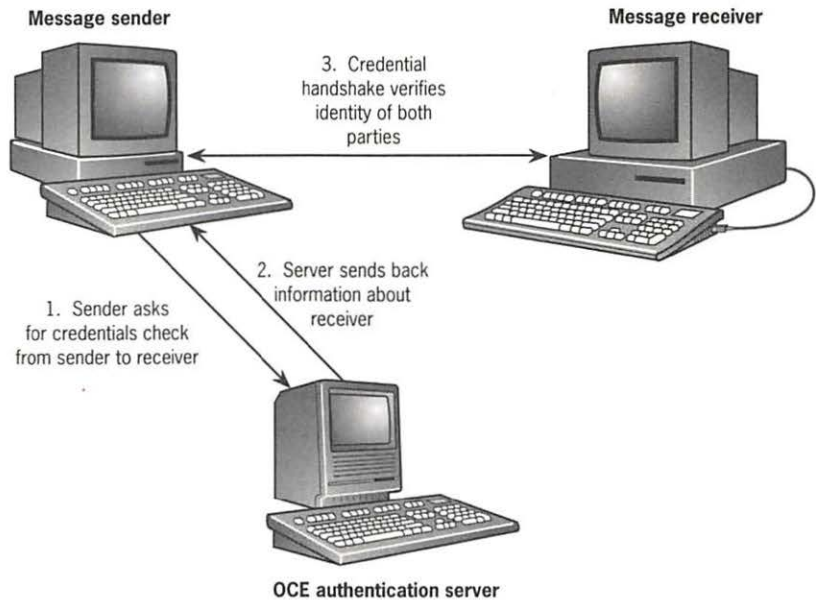

Once authentication is verified, the message can be sent. Encryption can be used to prevent wiretappers from reading what is transpiring. OCE provides automatic encryption as a message is being sent over a network, and automatic decryption when it gets to its destination—users need not see encrypted code. OCE-compatible applications will have a check box to turn encryption on and off. The actual encryption algorithm to be used by OCE is known as RC4. The RC4 encryption algorithm is very fast, along the lines of 1Mb per second, so users won't have to wait for encryption and decryption to occur.

Digital Signatures

In common law, a handwritten signature on a piece of paper, such as a check, ensures that the paper originated with the person who signed it and that the creator looked over the paper to ensure its accuracy. A bank that receives the check compares the signature against a sample signature to verify the authenticity of the document. OCE's digital signatures provide a similar set of guarantees for electronic documents, enabling them to be used as legally binding contracts and trustworthy records. OCE's digital signatures work

with messages that users send as well as messages that applications send to each other.

One type of encryption method, data encryption standard (DES), uses an electronic key to encrypt and decrypt a message. While it's more difficult to decipher than a password, DES has a problem similar to that of a password—you have to send the key along with your document, and therefore must be certain that the recipient is who he or she claims to be. OCE gets around this problem by using different keys to send and receive the document.

Documents using digital signatures become irrefutable, because the recipient Mac can tell if a document has been altered after the digital signature has been affixed. A digital signature is a specially encoded form of a document you want to send. First, an OCE “hashing” algorithm is used to create a message digest. Then, a unique private key is used to further encode the digest to form the digital signature (see Figure 14.5). Only the sender of the document has the private key. The digital signature is then attached to the original file.

When the package arrives at its destination, the recipient Mac separates the document from the digital signature. The digital signature is then turned back into a message digest using a public key that the sender has made available. To verify that the document is the same as the one that was sent, the OCE hashing algorithm attempts to recreate the message digest from the document it has received. This newly created digest is then compared to the digest that came with the message and unlocked with the public key. If the two digests are not the same, the Mac brings up a message screen informing the recipient that the received message has been altered during transit.

The likelihood that there is a mistake in the comparison of the received and recreated digests is extremely low: If a single bit in the transmitted message has been changed, the recreated digest will be altered by as much as 50 percent from the original.

■ Looking Ahead to OCE Applications

There's not much to OCE without OCE-compatible applications. The number of uses for OCE will increase as more and more applications become OCE-savvy. Additionally, as new technologies are developed and added to a network, new OCE service access modules can be developed that add new features to existing OCE-savvy applications, enabling further collaboration between users and between applications. What follows are some examples of how OCE will be used in applications.

Figure 14.5

OCE's digital signatures can tell if a document has been altered by comparing the received message digest with one reconstructed from the document itself.

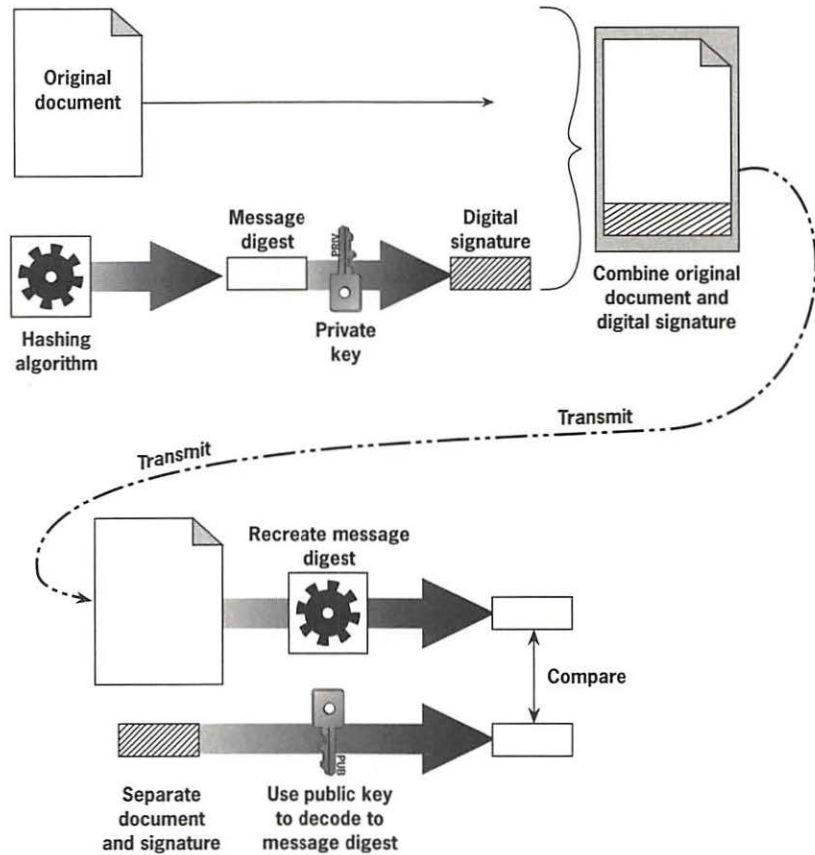

Working with an OCE-Aware Database

Although you can add data to OCE directories, OCE is not designed as a database engine. OCE will have minimal search capabilities, and won't provide the ability to do searches on fields. Searching and retrieval features are likely to be slower than most any database program you can think of. A database program that is OCE-compatible would be a very useful thing to have.

Luckily, one of the first OCE-compatible applications is a database product, Dynodex 3.0 from Portfolio Systems. Dynodex is a personal information manager (PIM) originally designed to contain telephone contacts. A PIM is an ideal type of application to use with OCE, since PIMs store the types of information that would be used in an OCE directory. Using an

OCE-compatible PIM would allow you to combine the records you keep in your PIM database with those in your OCE directories.

Dynodex 3.0 and later can be used as a front end to OCE directories as an alternative to Apple's standard template for viewing records in the directories. You could also keep a subset of OCE directory data in a program such as Dynodex for faster access than from within OCE. Dynodex 3.0 also has the ability to save a record to an OCE directory located on a network directory server or to a Personal Address Book residing on your Mac. You could add telephone and fax numbers of the people to whom you send electronic mail. With OCE, you'd have to type this information in by hand or copy and paste each entry for each record. However, this is the type of data that is commonly kept in a PIM such as Dynodex, so you could export the telephone numbers from Dynodex to the OCE directory.

Dynodex has all the useful data management features, such as complex searching and sorting, that you'd find in a personal database application. By importing the AppleTalk OCE directory, you could use Dynodex to search for certain types of users on a large network. You could also use Dynodex to print OCE directory data to envelopes and address book paper stock.

The OCE directory requires additional memory, which is usually in short supply on laptops. You could import OCE addresses from your desktop Mac into Dynodex on your laptop Mac, enabling you to carry your OCE data on your laptop without having to run OCE on the laptop.

One drawback with the initial OCE-savvy version of Dynodex is that OCE directory data created with Dynodex will not be able to be viewed with Apple's Finder template, but will have to be viewed using Dynodex. Portfolio has indicated that future versions of Dynodex will be able to write template-viewable OCE directory data.

Telephones and Electronic Mail

Earlier in the chapter I mentioned that the Mailbox icon in the Finder could receive voice mail. One of the ways it could do this is by using a product such as PhonePro from Cypress Research, an OCE-aware hardware and software package that connects a telephone to a Mac. Using PhonePro's scripting language, you can create a Mac-based, network office voice mail system for thousands of dollars less than a dedicated system would cost.

Such a system could make good use of all four of the OCE core services, as well as the connections to other technologies that OCE offers through its service access modules. Based on the type of message or form, an event-driven scripted software agent could process the input, forward it on for further processing, or file the message in an appropriate location.

For example, as sales input is electronically received from the field, a scripted software agent could be running unattended on a user's computer at

headquarters and take action based on the incoming message. This action could be unattended telephone calls for telemarketing purposes or beeper notification. And because digital signatures verify that a message has been unaltered, a reliable electronic “paper trail” of telephone and electronic mail transactions can be kept for purposes of accountability.

OCE in Workgroups and Workflow

Stand-alone accounting applications, which typically have a single user interface for input and printing for output, could use OCE to offer a whole new range of services. For instance, a just-in-time inventory control system could be set up using an accounting package, a telecommunications product such as PhonePro, and OCE. When inventory is running low, the accounting software could automatically send a telephone or fax message to a supplier to order new stock. When a report needs to be distributed to selected managers, the accounting package could distribute reports automatically through the organization, regardless of the electronic mail system the managers are using.

A popular off-the-shelf database package used to track customer profile and sales information could become a centralized customer management system. OCE could provide automatic distribution of customer profile and sales information to sales managers to help organizations better manage their customers. Customers could provide input directly to the database package on the phone for new sales orders or customer service. OCE allows the database package to communicate with people or other applications that depend upon critical customer information.

Another possible use of OCE is in workflow systems, large corporate transaction applications that move information around a company between different systems and locations. Workflow systems are usually specially developed in-house or by consultants at a significant investment in cost and time. Because it provides the transport mechanics and security required for workflow systems, OCE can save months of development time.

As we’ve seen from these few examples, OCE will allow software packages to offer new capabilities not previously envisioned. With potential links to virtually any transport and directory standard, as well as the use of on-line multimedia, the most interesting uses of OCE are yet to come.

■ Appendix

■ Connectivity MiniFinder

This appendix contains the addresses and phone numbers of most of the companies mentioned in the book, plus many major suppliers that aren't mentioned. The majority of the companies listed have been in business for several years and have proven to be reputable providers of quality products. Capsule reviews of many of the products listed here are published in *MacUser* magazine's "MiniFinders" section, which is published several times a year. More lengthy product reviews can be found periodically in *MacUser*, *MacWorld*, and *MacWeek* magazines.

This appendix is divided into product categories similar to the chapters of the book. Several companies appear in more than one category. Where not obvious, I've mentioned the types of products that are pertinent for the product category the company is listed under. Exceptions include the "Modems" category (these companies all sell modems) and the "Networks: Ethernet" category (these companies have large hardware product lines consisting of Ethernet interface cards, hubs, routers, or all three). Many of the companies in the latter category sell LocalTalk-to-Ethernet routers as well.

Since Apple has products in just about every category, I'll give its address and phone number here:

Apple Computer
20525 Mariani Avenue
Cupertino, CA 95014
(408) 996-1010

Mac-to-PC

Apple Computer

(see above)

- Various utilities, including DOS mounting and translation.

Argosy Software, Inc.

113 Spring Street, Fifth Floor
New York, NY 10012
(212) 274-1199

- RunPC remote control of PC from Mac and Software Bridge file translation.

DataViz Inc.

55 Corporate Drive
Trumbull, CT 06611
(203) 268-0030

- MacLinkPlus file translation.

Dayna Communications, Inc.

50 S. Main Street, Fifth Floor
Salt Lake City, UT 84144-0402
(801) 531-0600

- Various hardware and software, including those that enable using DOS disks and accessing Novell Netware.

Daystar Digital

5556 Atlanta Highway
Flowery Branch, GA 30542
(404) 967-2077

- AppleTalk card and software for PCs.

Extended Systems

6123 N. Meeker Avenue
Boise, ID 83704
(208) 322-7575

- Various solutions for connecting to PC printers, including Bridgeport printer-sharing device.

Farallon Computing, Inc.

2000 Powell Street, Suite 600
Emeryville, CA 94608
(510) 596-9100

- Various hardware and software, including the PhoneNET Talk AppleTalk card and software for PCs and remote control of Macs and PCs.

GDT Softworks, Inc.

PO Box 1865
Pt. Roberts, WA 98281
(604) 291-9121
(800) 663-6222

- Software for connecting to PC printers.

Insignia Solutions

526 Clyde Avenue
Mountain View, CA 94043
(415) 694-7600
(800) 848-7677

- Various software, including SoftPC DOS emulation, mounting DOS disks, and access to Novell Netware.

Insight Development Corp.

2200 Powell Street
Emeryville, CA 94608
(510) 652-4115
(800) 825-4115

- Software for connecting to PC printers.

Miramar Software

201 N. Salsipuedes, Suite 204
Santa Barbara, CA 93103
(805) 966-2432

- MacLAN Connect gateways for connecting Mac and PC networks.

Orange Micro

1400 N. Lakeview Avenue
Anaheim, CA 92807
(714) 779-2772

- Various hardware and software, including Orange386 PC board for Mac and Grappler for printing to DOS printers.

Traveling Software

18702 N. Creek Parkway
Bothell, WA 98011
(206) 483-8088

- LapLinkMac file translation.

Telecommunications

Compression Utilities

Aladdin Systems

165 Westridge Drive
Watsonville, CA 95076
(408) 761-6200

Alsys Software Corp.

1231 31st Avenue
San Francisco, CA 94122
(415) 566-2263

Salient Software

124 University Avenue, Suite 300
Palo Alto, CA 94301
(415) 321-5375

Communications Software

FreeSoft Company

105 McKinley Road
Beaver Falls, PA 15010
(412) 846-2700

Hayes Microcomputer Products, Inc.

PO Box 105203
Atlanta, GA 30348
(404) 840-9200

Magnum Software

21115 Devonshire Street, Suite 337
Chatsworth, CA 91311
(818) 700-0510

Software Ventures, Inc.

2907 Claremont Avenue
Berkeley, CA 94705
(510) 644-3232

Spider Island Software

4790 Irvine Blvd., Suite 105-347
Irvine, CA 92720
(714) 669-9260

Synergy Software

2457 Perkiomen Avenue
Mt. Penn, PA 19606
(215) 779-0522

Modems and Fax Modems**Abaton, a division of Everex Systems**

48431 Milmont Drive
Fremont, CA 94538
(510) 498-1111
(800) 628-3837

Computer Friends

14250 NW Science Park Drive
Portland, OR 97229
(503) 626-2291

Dove Computer Corp.

1200 N. 23rd Street
Wilmington, NC 28405
(919) 763-7918

Global Village

685 E. Middlefield Road
Mountain View, CA 94043
(415) 329-0700

Hayes Microcomputer Products, Inc.

PO Box 105203
Atlanta, GA 30348
(404) 840-9200

Microcom

500 River Ridge Drive
Norwood, MA 02062-5028
(617) 551-1000

Prometheus Products, Inc.

9524 SW Tualatin Sherwood Road
Tualatin, OR 97062
(503) 692-9600
(800) 328-2337

On-line Services

America Online Inc.

8619 Westwood Center Drive, Suite 200
Vienna, VA 22182
(703) 448-8700
(703) 893-6288 (outside of U.S.)
(800) 227-6364

Apple Computer, Inc.

(see beginning of this appendix)

- AppleLink

CompuServe Information Service

5000 Arlington Centre Blvd.
PO Box 20212
Columbus, OH 43220
(614) 457-8600

Delphi

1030 Massachusetts Avenue
Cambridge, MA 02138
(617) 491-3393

General Electric Informations Services (GENie)

401 N. Washington Street
Rockville, MD 20850
(301) 340-4000
(800) 638-9636

MCI Mail

PO Box 1001
1111 19th Street NW, Suite 500
Washington, DC 20036
(202) 833-8484

Prodigy Services Company

445 Hamilton Avenue
White Plains, NY 10601
(800) 776-3449

Portable Computing**Apple Computer, Inc.**

(see beginning of this appendix)

- AppleTalk Remote Access, StyleWriter portable inkjet printer.

Concentrix Technology, Inc.

1875 S. Grant Street, Suite 760
San Mateo, CA 94402
(415) 358-8600

- Connections Wizard Link cable and software for connecting Mac to Sharp Wizard, as well as personal productivity software for traveling.

Farallon Computing, Inc.

2000 Powell Street, Suite 600
Emeryville, CA 94608
(510) 596-9100

- Timbuktu Power Pack, remote-control software for Mac, and assorted connectivity tools for travel.

Global Village

685 E. Middlefield Road
Mountain View, CA 94043
(415) 329-0700

- Fax modems for the PowerBook.

Hewlett-Packard

5301 Stevens Creek Blvd.
Santa Clara, CA 95052
(800) 752-0900

- Portable productivity hardware, including 95LX Palmtop PC and DeskWriter inkjet printer.

Outbound Systems, Inc.

4840 Pearl East Circle
Boulder, CO 80301
(303) 786-9200

- The NoteBook series of Mac-compatible laptops.

Microcom

500 River Ridge Drive
Norwood, MA 02062-5028
(617) 551-1000

- CarbonCopy Mac, remote control of Mac.

Shiva Corporation

One Cambridge Center
Cambridge, MA 02142
(617) 252-6300

- LANRover server for AppleTalk Remote Access.

Networks

ARCnet Interface Boards

Actinet Systems, Inc.

360 Cowper, No. 11
Palo Alto, CA 94301
(415) 326-1321

- ARCnet network interface cards.

Standard Microsystems

80 Arkay Drive
Hauppauge, NY 11788
(516) 273-3100

Thomas-Conrad, Corp.

1908-R Kramer Lane
Austin, TX 78758
(512) 836-1935

Ethernet Boards, Hubs, and Routers**Apple Computer, Inc.**

(see beginning of this appendix)

APT Communications, Inc.

9607 Dr. Perry Road
Ijamsville, MD 21754

Asanté Technologies, Inc.

404 Tasman Drive
Sunnyvale, CA 94089
(408) 752-8388
(800) 662-9686

Cabletron Systems

35 Industrial Way
PO Box 5005
Rochester, NH 03867
(603) 332-9400

Compatible Systems Corporation

PO Box 17220
Boulder, CO 80308
(303) 444-9532
(800) 356-0283

Cayman Systems, Inc.

University Park at MIT
26 Landsdowne Street, Third Floor
Cambridge, MA 02139
(617) 494-1999

Dayna

50 S. Main Street, Fifth Floor
Salt Lake City, UT 84144-0402
(801) 531-0600

Dove Computer Corp.

1200 N. 23rd Street
Wilmington, NC 28405
(919) 763-7918

Engage Communication, Inc.

9053 Soquel Drive, Suite 201
Aptos, CA 95003
(408) 688-1021

EMAC, a division of Everex Systems Inc.

48431 Milmont Drive
Fremont, CA 94538
(800) 628-3837

Farallon Computing, Inc.

2000 Powell Street, Suite 600
Emeryville, CA 94608
(510) 596-9100

National Semiconductor

2900 Semiconductor Drive, M/S 16-195
PO Box 58090
Santa Clara, CA 95052
(408) 721-5020
(800) 538-8510

Network Resources Corp.

736 S. Hillview Drive
Milpitas, CA 95035
(408) 263-8100

Racal Datacom

155 Swanson Road
Boxborough, MA 01719
(508) 263-9929
(800) 526-8255

Shiva Corporation

One Cambridge Center
Cambridge, MA 02142
(617) 252-6300

Sonic Systems

333 W. El Camino, Suite 280
Sunnyvale, CA 94087
(408) 725-1400

TechWorks

4030 Braker Lane West, Suite 350
Austin, TX 78759
(512) 794-8533
(800) 688-7466

Tribe Computer Works

1195 Park Avenue, Suite 211
Emeryville, CA 94608
(510) 547-3874

Webster Computer Corp.

2109 O'Toole Avenue, Suite J
San Jose, CA 95131-1338
(408) 954-8054

The Wollongong Group, Inc.

1129 San Antonio Road
PO Box 51860
Palo Alto, CA 94303-4374
(415) 962-7100

Token Ring**Apple Computer, Inc.**

(see beginning of this appendix)

Asanté Technologies, Inc.

404 Tasman Drive
Sunnyvale, CA 94089
(408) 752-8388
(800) 662-9686

Avatar

65 South Street
Hopkinton, MA 01748
(508) 435-3000

Digital Communications Associates, Inc.

1000 Alderman Drive
Alpharetta, GA 30202
(404) 442-4000

Network Services

Apple Computer, Inc.

(see beginning of this appendix)

- AppleShare File Server.

Banyan Systems, Inc.

120 Flanders Road
Westboro, MA 01581
(508) 898-1000

- VINES network operating system.

CE Software, Inc.

1801 Industrial Circle
PO Box 65580
West Des Moines, IA 50265
(515) 224-1995

- QuickMail electronic mail.

cc:Mail, Inc., a division of Lotus

2141 Landings Drive
Mountain View, CA 94043
(415) 961-8800
(800) 448-2500

- cc:mail electronic mail.

Mainstay

5311-B Darry Avenue
Agoura Hills, CA 91301
(818) 991-6540

- Meeting Maker network calendar and scheduling software.

Microsoft

One Microsoft Way
Redmond, WA 98052-6399
(206) 882-8080

- Microsoft Mail, Schedule+ network calendar, LAN Manager network operating system.

Novell Inc.

122 E. 1700 South
Provo, UT 84606
(801) 379-5900

- Netware network operating system and DataClub distributed file serving.

Now Software

319 SW Washington, 11th floor
Portland, OR 97204
(503) 274-2800
(800) 237-3611

- Now Up-to-Date network calendar software.

Sitka Corporation

950 Marina Village Parkway
Alameda, CA 94501
(510) 769-9669

- TOPS distributed file serving.

StarNine Technologies, Inc.

2550 Ninth Street, Suite 112
Berkeley, CA 94710
(510) 548-0391

- Gateways for electronic mail systems.

WordPerfect Corp.

1555 N. Technology Way
Orem, UT 84057
(801) 222-5000
(800) 451-5151

- WordPerfect Office electronic mail.

Cutting Edge Networks**Corning Incorporated**

Opto-Electronics Group
MP-RO-03
Corning, NY 14831
(800) 525-2524

- Optical cabling.

BICC Communications

103 Millbury Street
Auburn, MA 01501
(508) 832-8650

- Infrared token ring.

Du Pont Electro-Optic Products Group

PO Box 13625
Research Triangle Park, NC 27709
(919) 481-5100
(800) 888-5261

- Various Ethernet and token ring hardware involving fiber-optic cable, including LAN1 line of optical hardware for Ethernet and token ring.

Motorola, Inc.

3215 Wilke Road
Arlington Heights, IL 60004
(708) 632-4723
(800) 233-8077

- Altair radio Ethernet.

Photonics Corp.

2940 N. First Street
San Jose, CA 95131
(408) 955-7930

- Infrared networking.

Codenall Technology Corporation

1086 North Broadway
Yonkers, NY 10701
(914) 965-6300

- CodeNet FDDI network-interface cards for Macintosh, as well as related hardware.

Wide-Area Networks

Apple Computer, Inc.

(see beginning of this appendix)

- Various hardware and software solutions for connecting Macs to networks running OSI protocols, such as X.400 and X.25.

Cayman Systems, Inc.

University Park at MIT
26 Landsdowne Street, Third Floor
Cambridge, MA 02139
(617) 494-1999

- Wide-area network routers for AppleTalk.

Cisco Systems Inc.

1525 O'Brien Drive
Menlo Park, CA 94025
(415) 326-1941

- Wide-area network routers and other related hardware for multiple network types.

Engage Communication, Inc.

9053 Soquel Drive, Suite 201
Aptos, CA 95003
(408) 688-1021

- Wide-area network routers including SyncSatellite for satellite communications.

Hayes Microcomputer Products, Inc.

PO Box 105203
Atlanta, GA 30348
(404) 840-9200

- ISDN interfaces for Macintosh.

Shiva Corporation

One Cambridge Center
Cambridge, MA 02142
(617) 252-6300

- Wide-area network routers for AppleTalk.

Ungermann-Bass, Inc.

3900 Freedom Circle
PO Box 58030
Santa Clara, CA 95052-8030
(408) 496-0111

- Wide-area network routers and related hardware.

Mac-to-UNIX

Apple Computer, Inc.

(see beginning of this appendix)

- Various Mac-to-UNIX connectivity solutions, including AU/X UNIX for Mac and MacX, X Window server software for Mac.

Cayman Systems, Inc.

University Park at MIT
26 Landsdowne Street, Third Floor
Cambridge, MA 02139
(617) 494-1999

- Various hardware and software solutions for Mac-to-UNIX connectivity, including the Gator line of gateways and XGator, X Window client for Mac.

InterCon Systems Corp.

950 Herndon Parkway, Suite 420
Herndon, VA 22070
(703) 709-9890

- Various software providing UNIX and TCP/IP services for Mac, including Planet X, X Window client for Mac, and TCP/Connect II, TCP/IP services for Macs.

Information Presentation Technologies

PO Box 12607
San Luis Obispo, CA 93405
(805) 541-3000

- UNIX-based network services for Mac users, including uShare AFP file server.

Quorum

4700 Bohannon Drive, Suite 125
Menlo Park, CA 94025
(415) 323-3111

- Mac operating system emulators for UNIX workstations.

Synergy Software

2457 Perkiomen Avenue
Mt. Penn, PA 19606
(215) 779-0522

- VersaTerm telecommunications and FTP file transfer.

Tenon Intersystem

1123 Chapala Street, Suite 202
Santa Barbara, CA 93101
(805) 963-6983

- MachTen UNIX for Mac.

The Wollongong Group, Inc.

1129 San Antonio Road
PO Box 51860
Palo Alto, CA 94303-4374
(415) 962-7100

- Various connectivity solutions, including Pathway Client NFS, which enables Macs to access NFS servers on UNIX machines.

White Pine Software

40 Simon Street, Suite 201
Nashua, NH 03060-3043
(603) 886-9050

- Various Mac-to-host solutions, including eXodus, X Window server software for Mac.

Xinet

2560 Ninth Street, Suite 312
Berkeley, CA 94710
(510) 845-0555

- UNIX-based services for Mac users, including K-AShare AFP file server.

Mac-to-VAX/VMS**Apple Computer, Inc.**

(see beginning of this appendix)

- AppleTalk for VMS.

Alisa Systems

221 East Walnut Street, Suite 175
Pasadena, CA 91101
(818) 792-9474

- VAX-based AFP file serving and mail services.

Andyne Computing Limited

552 Princess Street, Second Floor
Kingston, Ontario K7L 1C7
Canada
(613) 548-4355
(800) 267-0665

- GQL geographic front end for databases.

Digital Equipment Corporation

146 Main Street
Maynard, MA 01754-2571
(508) 493-5111

- PathWorks, complete network services running on VAX, as well as other Mac-to-VAX connectivity products.

Pacer Software, Inc.

7911 Herschel Avenue, Suite 402
La Jolla, CA 92037
(619) 454-0565

- VAX-based AFP file servering and terminal emulation.

Synergy Software

2457 Perkiomen Avenue
Mt. Penn, PA 19606
(215) 779-0522

- VersaTerm-PRO VT terminal emulation.

Webster Computer Corporation

2109 O'Toole Avenue, Suite J
San Jose, CA 95131-1303
(408) 954-8054

- NAS Administrator, Pathworks administration on a Mac.

White Pine Software

40 Simon Street, Suite 201
Nashua, NH 03060-3043
(603) 886-9050

- Various VT text and graphics terminal emulation.

Mac-to-Mainframe

Apple Computer, Inc.

(see beginning of this appendix)

- Various hardware and software for connections and terminal emulation, including SNA•ps terminal emulation.

Apple Programmers and Developers Association (APDA)

Apple Computer, Inc.
20525 Mariani Avenue, MS 33G
Cupertino, CA 95014
(408) 562-3910
(800) 282-2732
(800) 637-0029 in Canada

- MacAPPC development environment for LU 6.2 Mac applications as well as Mac3270 API.

Andrew KMW Systems, Corp.

4301 Westbank Drive, Suite A-100
Austin, TX 78746
(512) 314-3000

- Connections to IBM AS/400 midrange systems and 5250 terminal emulation.

Avatar Corp.

65 South Street
Hopkinton, MA 01748
(508) 435-3000

- Hardware for all types of mainframe connections, SNA gateways, terminal emulation, and front-ending software, including the MacMainframe line of software and the NetWay gateway.

CEL Software

PO Box 8339, Station F
Edmonton, Alberta T6H 4W6
Canada
(403) 463-9090

- BlackSmith front-end building software.

Connectivité Corporation

220 White Plains Road
Tarrytown, NY 10591
(914) 631-5365

- Both front-end building software.

Digital Communications Associates, Inc.

1000 Alderman Drive
Alpharetta, GA 30202
(404) 442-4000

- Hardware for coax and token ring mainframe connections, SNA gateways, 3270 terminal emulation, and front-ending API.

IBM Corporation

1133 Westchester Avenue
White Plains, NY 10604
(800) 426-3333

- Various mainframe-based services for Mac, such as LANRES/VM file services and Workstation Data Save Facility/VL backup.

IDEAssociates

29 Dunham Road
Billerica, MA 01821
(508) 663-6878

- Front-ending software, Mac-to-AS/400 twinax connectivity hardware, and 5250 terminal emulation software.

Mariette Systems International

29 El Cerrito Avenue
San Mateo, CA 94402
(415) 344-1519

- MacPROFF, a Mac front-end software for IBM's PROFS/OfficeVision.

Mitem Corp.

2105 Hamilton Avenue, Suite 350
San Jose, CA 95125
(408) 559-8801

- MitemView front-end building tool.

Novell Inc.

122 E. 1700 South
 Provo, UT 84606
 (801) 379-5900

- SNA gateway software for Netware.

Simware

20 Colonnade Road
 Ottawa, Ontario K2E 7M6
 Canada
 (613) 727-1779

- SimMac terminal emulation and front-ending software, as well as SIM 3278 protocol converter mainframe software for asynchronous communications.

Database Connectivity**ACIUS**

10351 Bubb Road
 Cupertino, CA 95014
 (408) 252-4444

- 4th Dimension line of database client and server software, including DAL and Sybase SQL connectivity.

Apple Programmers and Developers Association (APDA)

Apple Computer, Inc.
 20525 Mariani Avenue, MS 33G
 Cupertino, CA 95014
 (408) 562-3910
 (800) 282-2732
 (800) 637-0029 in Canada

- Data Access Language (DAL) servers for various host platforms as well as DAL developer's kits.

Blyth Software

1065 E. Hillsdale Blvd., Suite 300
 Foster City, CA 94404
 (415) 571-0222

- Omnis7 database software.

Brio Technology, Inc.

444 Castro Street, Suite 810
Mountain View, CA 94041
(415) 961-4110

- DAL-compatible data query and analysis software.

Claris

5201 Patrick Henry Drive
Santa Clara, CA 95052
(408) 727-8227

- Various DAL-compatible office-productivity applications.

ClearAccess Corporation

200 West Lowe Street
Fairfield, IA 52556
(515) 472-7077
(800) 522-4252

- Front-ending software that enables Mac applications to query SQL databases.

Everywhere Development Corporation

2176 Torquay Mews
Mississauga, Ontario, Canada L5N 2M6
(416) 819-1173

- Butler DAL-compatible database server for Mac host.

GeoQuery Corporation

475 Alexis R. Shuman Blvd., Suite 85E
Naperville, IL 60563-8453
(708) 357-0537

- GeoQuery geographical analysis application.

MapInfo Corporation

200 Broadway Avenue
Troy, NY 12180
(518) 274-8673
(800) 327-8627

- MapInfo geographical analysis application.

Microsoft Corporation

One Microsoft Way
Redmond, WA 98092
(206) 882-8080

- FoxBase database software.

Oracle Corp.

500 Oracle Parkway
Redwood Shores, CA 94065
(415) 506-7000

- Client and database server software for Macs and minicomputers.

Pacer Software, Inc.

7911 Herschel Avenue, Suite 402
La Jolla, CA 92037
(619) 454-0565

- DAL server for UNIX workstations.

Strategic Mapping, Inc.

4030 Moorpark Avenue, Suite 250
San Jose, CA 95117
(408) 985-7400

- Atlas Pro geographical analysis application.

Tactics International

16 Havenhill Street
Andover, MA 01811
(508) 475-4475
(800) 927-7666

- Tactician geographical analysis application.

TechGnosis, Inc.

301 Yamato Road, Suite 2200
Boca Raton, FL 33431
(407) 997-6687

- SequeLink SQL API for Mac access to SQL databases.

Network Management Tools

The AG Group

22540 Camino Diablo, Suite 202
Walnut Creek, CA 94596
(510) 937-7900

- Net Watchman network-monitoring software, and LocalPeek and EtherPeek protocol-analyser software.

Apple Computer, Inc.

(see beginning of this appendix)

- Inter•Poll network traffic-monitoring software.

Cabletron Systems, Inc.

35 Industrial Way
PO Box 6257
Rochester, NH 03867
(603) 332-9400

- LANVIEW hardware-protocol analyzer.

Caravelle Networks Corporation

301 Moodie Drive, Suite 306
Nepean, Ontario K2H 9C4
Canada
(613) 596-2802

- Mac-to-Mac NetWORKS network-monitoring software.

CSG Technologies

530 William Penn Place, Suite 329
Box 131
Pittsburgh, PA 15219-1820
(412) 471-7170
(800) 366-4622

- Network SuperVisor network-inventory software.

Dantz Development

1400 Shattuck Avenue, Suite 1
Berkeley, CA 94709
(510) 849-0293

- Retrospect Remote network-backup software.

Dayna Communications, Inc.

50 S. Main Street, Fifth Floor
Salt Lake City, UT 84144-0402
(801) 531-0600

- Various network-management applications, including Vital Signs network-monitoring software, and NetScope traffic-monitoring software.

EDI Communications Corporation

20440 Town Center Lane, Suite 4E
Cupertino, CA 95014
(408) 996-1343

- MacToken protocol analyser for token ring.

Ex Machina, Inc.

45 E. 89th Street, Suite 39-A
New York, NY 10128-1251
(212) 831-3142

- Notify! pager-notification software.

Farallon Computing, Inc.

2000 Powell Street, Suite 600
Emeryville, CA 94608
(510) 596-9100

- Various network-management tools, including TrafficWatchII network traffic-monitoring software and NetAtlas topological network-mapping software.

Golden Triangle

4849 Ronson Court, Suite 206
San Diego, CA 92111-1805
(619) 279-2100

- SnapBack network-backup software.

Hewlett-Packard

5301 Stevens Creek Blvd.
Santa Clara, CA 95052
(800) 752-0900

- Hardware-protocol analyzers, including the HP 4980 Network Advisor line.

MacVonk

313 Iona Avenue
Narbeth, PA 19072
(215) 660-0606

- NetOctopus network inventory, software updating.

Neon Software, Inc.

1009 Oak Hill Road, Suite 203
Lafayette, CA 94549
(510) 283-9771

- Netminder line of protocol-analyzer software and RouterCheck SNMP-capable network-monitoring software.

Network General Corp.

4200 Bohannon Drive
Menlo Park, CA 94025
(415) 688-2700

- Sniffer line of hardware-protocol analyzers.

On Technology

155 Second Street
Cambridge, MA 02141
(617) 876-0900

- Status•Mac network inventory, updating software.

Sonic Systems

333 W. El Camino, Suite 280
Sunnyvale, CA 94087
(408) 725-1400

- Radar network-inventory software with updating and monitoring functions.

TechWorks

4030 Braker Lane West, Suite 350
Austin, TX 78759
(512) 794-8533
(800) 688-7466

- GraceLAN line of network inventory, software-updating applications.

Trik, Inc.

400 W. Cummings Park, Suite 2350

Woburn, MA 01801

(617) 933-8810

(800) 766-0356

- NetDistributer updating software.

■ Index

A

- AARP (AppleTalk Address Resolution Protocol), 275
- Abaton, a division of Everex Systems, address of, 333
- AccessPC, as DOS drive-mounting utility, 12, 13, 14, 19
- access privileges, 132, 138
- Access Server
 - as DOS application server, 158
 - as DOS multiuser server, 22
- ACIUS
 - 4th Dimension, 150, 224, 238–239, 240, 242
 - address of, 349
- Actinet Systems, Inc., address of, 336
- active stars, 98–99
- Address Book Plus, 69
- Adobe Illustrator, 15–16
- Adobe PhotoShop, 16
- Adobe Type Manager (ATM), 41
- ADSP (AppleTalk Data Stream Protocol), 278
- ADSP tool, 189, 199
- Advanced Program-to-Program Communications (APPC), 226
- AEP (AppleTalk Echo Protocol), 277
- AFP. *See* Apple File Protocol
- AFP file servers, as UNIX hosts, 160, 181–182
- AFP volumes, mounted on networks, 132
- agents, defined, 322
- The AG Group
 - address of, 352
 - LocalPeek & EtherPeek, 280
 - Net Watchman, 270
- Aladdin Systems
 - address of, 332
 - SpaceMaker, 47
 - StuffIt Deluxe, 47
- alias, using with shared volumes, 137, 181
- AlisaMail, as mail integration package, 205–207
- AlisaShare, 160
- Alisa Systems, 204
 - address of, 345–346
 - AlisaMail, 205–207
 - AlisaShare, 160
 - AlisaTalk, 200, 203
 - MailMate, 205
 - MaxNotes, 205
- AlisaTalk, 200, 203
- All-in-1 Mail, 204
- All Points Addressable (APA) display language, 220
- ALSoft
 - DiskExpress II, 155
- Alsys Software Corp., address of, 332
- Altair, as wireless network, 95
- alternative Macs, 170–171
- American Airlines travel service, 53
- America Online, Inc., 50–51, 147
 - address of, 334
- Andrew KMW Systems, Corp.
 - address of, 347
 - TwinAcess board, 228
- Andyne Computing Limited
 - address of, 346
 - GQL tools, 242–243
- APA (All Points Addressable) display language, 220
- API (application program interface), 6, 190, 222, 223–224, 318
- APPC (Advanced Program-to-Program Communications), 226
- Apple Computer, Inc.
 - address of, 329
 - ADSP (AppleTalk Data Stream Protocol), 278
 - AEP (AppleTalk Echo Protocol), 277

- Apple File Protocol (AFP), 2, 24–25, 130, 160
- AppleScript, 322
- AppleTalk, 2, 21, 23, 78–79, 175, 190
- AppleTalk Address Resolution Protocol (AARP), 275
- AppleTalk Internet Router, 120, 126
- AppleTalk Phase 2, 106–108
- AppleTalk Remote Access, 58–61, 135–136, 137
- ASP (AppleTalk Session Protocol), 278
- ATP (AppleTalk Transaction Protocol), 277
- A/UX, 165–168
- coax cards for Macs, 212, 228
- DAL (Data Access Language), 151, 227, 232, 236–237
- Ethernet Cable System, 81–82
- HyperCard, 69, 198, 222, 223, 224, 242
- Inter•Poll, 268
- ISDN NB Card, 303
- LaserWriter, 2
- LocalTalk, 23, 62, 80–81
- MacAPPC (Macintosh Advanced Program-to-Program Communications), 226–227
- Mac IIci, 153–154
- Mac IIx, 154
- Macintosh PC Exchange, 12
- MacODA translator, 308–309
- Mac Quadra, 79, 82, 154
- Mac SE/30, 153
- MacTCP, 176, 178
- MacX25 software, 306
- Open Collaboration Environment (OCE), 150, 249, 312–328
- PowerBook, 57–58, 70–71
- Print Sharing Bus, 2
- QuickDraw, 30–31
- SNA•ps Gateway, 218
- StyleWriter, 62
- SuperDrive, 10–11
- TokenTalk NB card, 216
- TrueType fonts, 41
- Apple File Exchange, 11
- Apple File Protocol (AFP), 2, 130
 - access privileges and folder icons of, 140
 - adding Macs to PC networks with, 24–25
 - compliance modules, 24–25
 - in network services, 160
- AppleLink, 51
- Apple Print Sharing Bus, 2
- Apple Programmers and Developers Association (APDA), address of, 347, 349
- AppleScript, 322
- AppleShare, 2
 - Admin utility, 140–142
 - Chooser extension, as system extension service, 131, 132
 - File Server, 130, 138–143
 - future versions of, 156
 - Print Server, 143
 - security features of, 138–139
 - setting up of, 139–143
- AppleTalk
 - Address Resolution Protocol (AARP), 275
 - Administration Daemon (ATalkAD), 294
 - Data Stream Protocol (ADSP), 278
 - Internet, 289
 - Internet Router, 120, 126
 - as Macintosh networking environment, 2, 21, 23, 78–79, 175, 190
 - Phase 2, 106–108, 126
 - Remote Access, 58–61, 135–136, 137
 - Session Protocol (ASP), 278
 - Transaction Protocol (ATP), 277
 - Update Routing Protocol (AURP), 176, 287–289
 - for VAX, 190, 193
- AppleTalk-to-DECnet Transport Gateway, 193
- Apple update-based routing protocol, 286–289
- application program interface (API), 6, 190, 222, 223–234, 318

- APT Communications, Inc., address of, 337
- architecture
- NAS (Network Application Support), 200–201, 245
 - open document (ODA), 308–309
 - store-and-forward, 135, 147, 204, 205, 261, 312
- archives, self-extracting, 47
- ARCnet, as data link mechanism, 85
- ARCTalk, 85
- Argosy Software, Inc.
- address of, 329
 - RunPC, 21–22
 - RunPC/Remote, 14
 - Software Bridge, 17, 66
- Asanté Technologies, Inc.
- address of, 337, 339
 - coax cards for Macs, 212
 - Ethernet cards, 81, 83, 154
- AS/400 minicomputers, 224, 228
- ASP (AppleTalk Session Protocol), 278
- asset management, 258
- software, 259–260
- assigning network numbers, 125–126
- asynchronous communication, defined, 189
- asynchronous connections, 214–215
- ATalkAD (AppleTalk Administration Daemon), 294
- Atlas Pro, 244
- ATP (AppleTalk Transaction Protocol), 277
- AUI (attachment unit interface) port, 82
- AURP (AppleTalk Update Routing Protocol), 176, 287–289
- AURP routers, 294
- AURP routing, 291
- authentication and encryption, 323–324
- authentication and privacy services, of OCE, 316
- AutoDoubler, 47
- A/UX, as Apple's UNIX operating system, 165–168
- Avatar Corp.
- address of, 347
- coax cards for Macs, 212–214
- FrontCard, 224
 - LanWay card, 216
 - MacMainFrame, 211–212, 214, 219
 - MacMainFrame Graphics, 220
 - MacMainFrame Programmers Toolkit, 224
 - MAXDATA technology, 219
 - Netway 2000 gateway, 216
- B**
- backbone topology, 101–102, 115–116
- backing up over a network, 255–257
- Backup Server, IBMs as client-server solution, 227–228
- Balloon Help, in use on laptops, 70
- Banyan Systems, Inc.
- address of, 340
 - StreetTalk, 315
 - VINES, 25, 159
- Barron's*, 51
- Basic Mail for Macintosh, 204
- baud, defined, 35
- BeagleWorks, 68
- BICC Communications
- address of, 342
 - InfraLAN, 92–93
- Binary format, for transferring files, 45
- bits per second (bps), compared to baud, 35
- Blacksmith, 224, 225
- Blue Parrot, as print queue utility, 147
- Blyth Software
- address of, 349–350
 - Omnis, 150, 224, 242
- BNC connector, 89
- Both, as front-end application, 224
- bottlenecks, prevention of, 112
- bps. *See* bits per second
- BridgePort, as printer-network bridge, 29, 30
- bridges, 106, 109, 110. *See also* gateways; routers
- Brio Technology, Inc.
- address of, 350
 - Data Edit, 244

Data Pivot, 244
 Data Prism, 151, 244
 broadcast mechanisms, 82
 bulletin boards, 47. *See also* e-mail;
 forums
 bus topology, 96
 Butler, as database server, 151, 239

C

cables
 coaxial, 88–89
 fiber-optic, 89–91
 for modems, 38
 twisted-pair, 86–88
 Cabletron Systems, address of, 337, 352
 CAP (Columbia AppleTalk Package),
 176
 Caravelle Networks Corporation
 address of, 352
 Mac-to-Mac NetWORKS, 269
 Carbon Copy Mac, 66, 174, 258
 carrier media, 295–304
 Casa Blanca Works, Blue Parrot, 147
 Cayman Systems, Inc.
 address of, 337, 343, 344
 GatorBox, 176, 183, 293
 GatorMail, 183
 GatorPrint, 183
 GatorStar, 183
 XGator, 175
 cc:Mail, Inc., a division of Lotus, 148,
 149
 address of, 340
 CCITT (Consultative Committee on
 International Telegraph and
 Telephone), 37
 CCITT X.25, as industry standard data
 link protocol, 286
 CCL (communications control
 language), 43
 CDA (Compound Document
 Architecture), 309
 Cellular Data link, as cellular
 phone/modem, 65
 cellular modems, 64–65
 cellular phone/modem, 65
 CEL Software
 address of, 347–348
 Blacksmith, 224, 225
 centralized services, 134–135
 CE Software, Inc.
 address of, 340
 QuickMail, 148–149, 178, 315
 channels, in ISDN, 301–302
 channel service unit (CSU), 298
 Chooser desk accessory, 5, 59, 130, 131
 CIM (Compuserve Information
 Manager), 49
 Cisco Systems Inc., address of, 343
 Claris
 address of, 350
 ClarisWorks, 68
 FileMaker, 150
 Resolve, 68
 ClarisWorks, 68
 ClearAccess Corporation
 address of, 350
 ClearAccess, 243
 client-server, in centralized services, 135
 client-server computing in mainframe
 environment, 225–228
 CLient/Server for Macintosh, 241
 Client X Window, for the Mac, 174–175
 clustering network numbers, 292
 coax cards, 212–214, 228
 coaxial cabling, 88–89
 coaxial terminal adapter cards,
 212–214, 228
 Codenall Technology Corporation,
 address of, 342
 collaboration, 311–328
 collaborative computing, defined, 312
 collisions, in packet broadcasting, 82–83
 Columbia AppleTalk Package (CAP),
 176
 Commando, as command builder in
 A/UX, 166
 command shells, in UNIX, 166
 CommGate/MS & CommGate/QM, as
 gateways to Microsoft Mail and
 QuickMail, 150
 communicating with A/UX, 168
 communications, satellite, 298–300

- communications control language (CCL), 43
 - Communications Toolbox, 189–191, 319
 - Compact Pro, 47
 - Compatible Systems Corporation, address of, 337
 - Compound Document Architecture (CDA), 309
 - compression utilities, 46–47, 59, 332–333
 - CompuServe Information Manager (CIM), 49
 - CompuServe Information Service (CIS), 48–49
 - address of, 334
 - interfaces for, 49
 - Computer Currents*, 47
 - Computer Friends, address of, 333
 - Concentrix Technology, Inc.
 - address of, 335
 - Connections, 69
 - Connections Wizard Link, 74
 - configuring PC servers to accept Macintoshes, 24–26
 - connecting tunnels, 294–295
 - Connections, as personal organizer program, 69
 - Connections Wizard Link, 74
 - Connectivité Corporation
 - address of, 348
 - Both, 224
 - connectivity. *See also* internets; networks
 - database, 231–251
 - ease of use, 4–5
 - forms of, 2, 3
 - non-network forms of, 11–14
 - software, 66
 - uses of, 3
 - control packets, 278
 - control unit terminal (CUT) mode, for 3278/9 terminals, 218
 - core of OCE, 313–316
 - Corning Incorporated, address of, 341
 - Creator codes, for extension mounting, 13
 - CSG Technologies
 - address of, 352
 - 4D Developers kit, 262
 - Network SuperVisor & Network SuperVisor TE, 262
 - CSU (channel service unit), 298
 - CUT (control unit terminal) mode, for 3278/9 terminals, 218
 - cutting edge network products, 341–342
 - Cypress Research PhonePro, 327
- D**
- daisy chain, 96
 - DAL (Data Access Language), 151, 227, 232, 236–237
 - DAL server, 236
 - Dantz Development
 - address of, 352
 - Retrospect Remote, 255, 257
 - DARPA (Defense Advanced Research Projects Agency), 175, 178
 - data access, in VITAL system, 247–248
 - Data Access Language (DAL), 151, 227, 232, 236–237
 - Data Access Language Server from Tandem, 241
 - Data Access Manager, 233
 - database connectivity, 231–251
 - products, 349–351
 - database hooks, 232–234
 - databases, 150–151
 - working with OCE-aware, 326–327
 - database servers, 151
 - assessment of, 234
 - Mac-accessible, 237–241
 - data capture, in VITAL system, 246–247
 - Data Cell, as general-purpose tellular box, 65
 - DataClub, as distributed file server, 135, 144–146
 - DataClub Elite, as 50-user version of DataClub, 146
 - data compression, in modem transmission, 36, 37–38

- Data Edit, 244
- data encryption standard (DES), 325
- data fork, 45
- Datagram Delivery Protocol (DDP), 275, 278
- data link layer, in protocol stack, 275
- data link mechanisms, 79–80
- data packets, 278–279
- Data-PCS (Data-Personal Communication Services), 95
- Data Pivot, 244
- Data Prism, 151, 244
- data service unit (DSU), 297, 298
- data synchronization, 248–249
- DataViz Inc.
 - address of, 330
 - MacLinkPlus/PC, 14, 17, 18, 62, 220
- DAT (digital audio tape), as server backup medium, 156, 255
- Da Vinci Systems, MacAccess, 149–150
- Dayna Communication, Inc.
 - address of, 330, 337, 353
 - EtherPrint, 81
 - NetMounter, 25, 158
 - NetScope Console, 268
 - NetScope Probe, 268
 - Network Vital Signs, 270, 271
- DaynaFile, 11
- Daystar Digital
 - address of, 330
 - LT200 Connection, 23
 - as major supplier of LocalTalk cards, 23
- DBC/1012 Data Base Computer, 241
- DDIF (Digital Document Interchange Format), 202
- DDP (Datagram Delivery Protocol), 275, 278
- DDS (Distributed Directory Services), 204
- DECnet
 - File Access Listener, 193, 202
 - as gateway for VAX, 110
 - for Macintosh, 193
 - Network description, 192–193
 - as network protocol suite, 188
 - as products that implement Digital Network Architecture (DNA), 190
 - routing non-AppleTalk protocols through, 123
- DECwindows, as X Window System on VAX, 199–200
- DECwindows Toolkit, 200
- Defense Advanced Research Projects Agency (DARPA), 175
- defragmentation, of hard disk, 155
- Delphi, 53
 - address of, 334
- DES (data encryption standard), 325
- design templates, in VITAL system, 250
- desktop integration, in VITAL system, 248–249
- DeskWriter, 62
- device monitoring software, 254
- device pooling, described, 146
- device status, monitoring of, 269–270
- DFT (distributed function terminal) mode, for 3278/9 terminals, 218
- diffuse transmission, 92
- digital audio tape (DAT), as server backup medium, 156, 255
- Digital Communications Associates, Inc.
 - address of, 339, 348
 - coax cards for Macs, 212–214
 - IRMALAN/EP Gateway, 216
 - IRMA WorkStation, 220–221
 - MacIRMA Developers Toolkit, 224
 - MacIRMAtrac card, 216
 - MacIrmatrac Fiber, 91
 - as major source for Mac-to-mainframe link, 211–212
- Digital Data Communication Message protocol, 192
- Digital Document Interchange Format (DDIF), 202
- Digital Equipment Corporation
 - address of, 346
 - All-in-1 Mail, 204
 - DECnet File Access Listener, 193
 - DECnet for Macintosh, 193
 - DECwindows Toolkit, 200

- Digital Data Communication
 - Message protocol, 192
 - Distributed Directory Services (DDS), 204
 - MAILbus products, 204
 - MicroVAX, 188
 - Network Application Support (NAS) network architecture, 200–201, 245
 - PathWorks, 160, 179, 200–203, 204
 - as user of X.400 e-mail system, 307
 - VAX, 187–207
 - VAXcluster, 188
 - VAX Rdb/VMS database, 240
 - digital lines, as carrier for WAN links, 297
 - Digital Network Architecture (DNA), 190
 - digital signatures, 324–325, 326
 - digital signature services, of OCE, 316, 326
 - Digital Table Interchange Format (DTIF), 202
 - directed transmission, 92
 - directories in the Finder, 316–318
 - directories (on PCs), 10
 - Directory Browser, in OCE, 314–315
 - directory services
 - integrated, 207
 - of OCE, 313–315
 - directory synchronization, defined, 205–206
 - disk duplexing, 158
 - DiskExpress II, 155
 - disk mirroring, 158
 - DiskTwin, 158
 - Dispatcher/SMTP, 178
 - displays. *See also* monitors
 - external color for laptops, 71
 - gray scale and color on DOS laptops, 73
 - display server, 171
 - Distributed Directory Services (DDS), 204
 - distributed function terminal (DFT)
 - mode, for 3278/9 terminals, 218
 - distributed processing servers, 152
 - distributed services, 134–135
 - Distribution Lists, 317
 - DNA (Digital Network Architecture), 190
 - DOS, 10
 - disk-mounting utilities, 12–13, 66
 - emulation of on Mac, 18–19
 - on laptops, 74–75
 - on Mac via network, 21–22
 - operation of on Mac, 18–22
 - DOS Mounter, 12
 - Dove Computer Corp., address of, 333, 337
 - Dow Jones News/Retrieval service, 51
 - drop box, defined, 139
 - DSU (data service unit), 297, 298
 - DTIF (Digital Table Interchange Format), 202
 - dueling protocols: OSI versus TCP/IP, 304–305
 - duplexing, disk, 158
 - Du Pont Electro-Optic Products Group
 - address of, 342
 - Ethernet, 29, 79, 81–82
 - LAN ONE fiber-optic product line, 91
 - dynamic node addressing, 112
 - Dynodex 3.0, 69, 326–327
- ## E
- EDI Communications
 - address of, 353
 - MacToken, 280–281
 - electromagnetic fields, in cabling, 90
 - electronic bulletin boards. *See* bulletin boards
 - Electronic Business Card, 317–318
 - electronic mail. *See* e-mail
 - EMAC, a division of Everex Systems Inc., address of, 338
 - e-mail, 66, 327–328. *See also* bulletin boards; forums
 - on LANs, 147
 - MCI, 51
 - software packages, 148–150
 - X.400, 307–308

- employing security, 323–325
 - emulation, terminal, 43–44, 194–199
 - encapsulated postscript (EPS), 15–16
 - encapsulation, 123–124, 287, 288
 - encryption, 323–324
 - Engage Communication, Inc., address
 - of, 338, 343
 - enterprise computing, 232, 244–246
 - enveloping, defined, 39
 - EPS (encapsulated postscript), 15–16
 - erasable optical media, as server
 - backup medium, 156
 - Ericsson GE Mobile Communications,
 - Mobidem Portable Wireless Modem, 73
 - error correction, in modem
 - transmission, 36, 37–38
 - Ethernet
 - on Macs, 79, 126, 154
 - as most popular data link mechanism, 81–82
 - as used with higher-end printers, 29
 - Ethernet boards, hubs, and routers,
 - guide to products, 337–339
 - Ethernet Cable System, 81–82
 - EtherPeek, 280
 - EtherPrint, 81
 - EtherTalk, 81, 126
 - Everywhere Development Corporation
 - address of, 350
 - Butler, 151, 239
 - Excel for Windows, 74
 - Executive Workstation, 223
 - eXene, as window manager, 173
 - Ex Machina, Inc.
 - address of, 353
 - Notify!, 73, 262, 270, 273
 - eXodus, as alternative X Window
 - System server, 173–174
 - exploring UNIX, 165–171
 - exploring the X Window System,
 - 171–175
 - Extended Systems
 - address of, 330
 - BridgePort, 29, 30
 - extension mapping, 12–13
 - exterior routers, 294
 - external floppy drives, 61–62
- F**
- Farallon Computing, Inc.
 - address of, 330, 335, 338, 353
 - Liaison, 120
 - as major supplier of LocalTalk cards, 23
 - NetAtlas, 262
 - PhoneNET Talk, 23–24
 - Timbuktu, 22, 66, 70, 174, 258
 - TrafficWatchII, 268, 269
 - FastPath, 176, 192
 - Fault Finder software, 283
 - fax modems, 39–41, 64
 - OCR (Optical Character Recognition) in use with, 39
 - FDDI (Fiber Distributed Data Interface), 86
 - FDHD. *See* SuperDrive
 - fiber-optic cabling, 89–91
 - fiber-optic products, 91
 - Fifth Generation Systems
 - SuperLaserSpool, 27, 146–147
 - 5250 terminal emulation, for IBMs
 - AS/400, 224, 228
 - file format, for file transfers, 45
 - FileMaker, 150
 - File and Print Services, 130–133
 - files, sharing of with PCs, 10
 - File Sharing, as system extension
 - service, 131, 132–133
 - file-sharing setup, 135–137
 - file transfer, 45, 195
 - File Transfer Protocol (FTP), 178
 - file transfer protocols, 45, 195
 - file transfer software, 14, 195
 - file translation, between Mac and PC,
 - 15–18
 - filters. *See* translation software
 - Finder, 11
 - directories in, 316–318
 - flat silver cable, 87, 88
 - floppy drives, external, 61–62
 - flow control pin, as connector pin in
 - Mac, 38
 - folders (on the Macintosh), 10
 - fonts, difficulties in translation from
 - Mac to PC, 15

form, as window for e-mail messages, 147
 FORMAC, 221
 forums. *See also* bulletin boards; e-mail custom, 53
 on on-line services, 54
 4D Developers kit, 262
 Fourth Dimension, 150, 224, 238–239, 240, 242
 fragmentation, of hard disk, 155
 frame capture tools. *See* packet analyzers
 Frame Relay, 298
 Freedom of Press, as PostScript emulator, 30
 FreeSoft Company
 address of, 332
 White Knight, 42
 friendly-net, 80–81
 FrontCard, as HyperCard toolkit, 224
 front-end development, 223–225
 front-ending host software, 221–225
 front-end solutions, off-the-shelf, 222–223
 FTP (File Transfer Protocol), 178

G

gateways, 106. *See also* bridges; routers and conferencing, 205
 DECnet, 110, 123, 188, 190, 192–193
 described, 110–111
 Mac-to-UNIX, 176–177, 182–183
 multi-access network, 216–218
 translation of packets in, 111
 GatorBox, 176, 183, 293
 GatorMail, 183
 GatorPrint, 183
 GatorStar, 183
 GDT Softworks, Inc.
 address of, 330
 JetLink Express, 27, 31
 General Electric Informations Services (GENie), 53
 address of, 334
 geographic maps, 244
 GeoQuery, 244

GeoQuery Corporation
 address of, 350
 GeoQuery, 244
 geosynchronous orbit, in satellite communication, 298
 global communication, 285–309
 Global Messaging Server, 319
 Global Village Communication
 address of, 333, 335
 PowerPort/v.32, 64
 Golden Triangle
 address of, 353
 DiskTwin, 158
 SnapBack, 255, 256–257
 Government Systems, Inc., phone number of, 178
 GQL tools, 242–243
 GraceLAN Asset Manager, 262
 GraceLAN Network Manager, 260, 261–262, 266
 GraceLAN Update Manager, 264–265, 266
 graphics files, difficulties in translation, 15–16
 graphic user interface (GUI), 164
 Grappler, as Mac-to-PC-printer connector, 27
 Grappler Share, 278
 GreatWorks, 68
Grolier's Electronic Encyclopedia, 53
 group, defined, 141
 GUI (graphic user interface), 164

H

half-routers, 122
 handshaking, 38–39
 hard drives, high capacity, 155
 HayesConnect, as serial server, 146
 Hayes, Dennis, 36
 Hayes Microcomputer Products, Inc.
 address of, 332, 333, 343
 HayesConnect, 146
 Smartcom II, 43, 44
 header, description of in packets, 278
 Heinen, Roger, 156
 helping users over a network, 255–258

- Hewlett-Packard
 - address of, 335, 353
 - DeskWriter, 62
 - Fault Finder software, 283
 - LaserJet laser printer, 26, 29
 - LaserJet PCL (printer command language), 31
 - 95LX, 73
 - HFS (hierarchical file system), as Macintosh file storage method, 24, 257
 - HLLAPI (High Level Language Application Program Interface), 223
 - hop count, 275, 292
 - hops
 - defined, 114
 - limits on, 115
 - hosts. *See also* servers
 - Tandem, 240–241
 - hubs
 - intelligent, 101
 - smart, 272
 - star, 88, 98, 100, 101
 - HyperCard, 69, 198, 222, 223, 224, 242
 - HyperTalk
 - as front-end development language, 222, 223, 224
 - as high-level programming language, 198
- I**
- IBM Corporation
 - address of, 348
 - APA (All Points Addressable) display language, 220
 - AS/400 minicomputers, 224, 228
 - Backup Server, 227–228
 - HLLAPI (High Level Language Application Program Interface), 223
 - Interactive Chart Utility, 221
 - LAN Resource Extension and Services/VM (LANRES/VM), 227
 - LAN Server, 26
 - mainframes, 209–228
 - MAU (multistation access unit), 85
 - PROFS/Office Vision, 222–223
 - S/36 & S/38 minicomputers, 228
 - SAA (System Application Architecture), 211, 245
 - SNA (Systems Network Architecture), 210–211
 - token rings, 83–85, 211, 215–216
 - VM operating systems, 227
 - Workstation Data Save Facility/VL, 227
 - IBM Mainframe, as database server, 240
 - ICONtact special interest group, 53
 - IDEAssociates
 - address of, 348
 - IDEAcomm Mac, 228
 - ID numbers, for nodes, 107
 - IEEE (Institute of Electrical and Electronic Engineers) standard, 81
 - IND\$FILE, as file transfer utility, 218, 219
 - Indigo, 152–153
 - Industrial, Scientific and Medical (ISM) frequency range, 94
 - Information Presentation Technologies
 - address of, 344
 - NETFinder, 182
 - Sun Partner, 182
 - UShare, 182
 - Information Switch, in AlisaMail, 205
 - InfraLAN, 92–93
 - infrared networks, 92–93
 - infrastructure, of VITAL system, 250
 - inkjet printers, 62
 - Inside AppleTalk*, 274
 - Insight Development Corp., MacPrint, 27, 30–31
 - Insignia Solutions
 - AccessPC, 12, 13, 14, 19
 - address of, 331
 - SoftNode, 25
 - SoftPC, 18–19
 - installation of software, 258
 - over a network, 263–265
 - installer programs, 265
 - Institute of Electrical and Electronic Engineers (IEEE) standard, 81

Integrated Computer Solutions Motif
 for A/UX, 167
 integrated directory services, 207
 integrated PC-based network operating
 systems, 157–159
 integrated services digital network
 (ISDN), 286
 integration services, defined, 248
 Intel 80386 processor, in laptops, 73
 intelligent hubs, 101
 Inter•Poll, 268
 Interactive Chart Utility, 221
 Intercon Systems Corp.
 address of, 344
 Dispatcher/SMTP, 178
 NFS/Share, 180–181
 Planet X, 175
 TCP/Connect II, 177, 178
 Internet Engineering Task Force, 272,
 286–287
 internets, 105–126. *See also* networks
 AppleTalk Internet, 289
 defined, 78
 local, 286
 planning of, 106, 111–118
 TCP/IP, 110, 123, 164, 168, 175, 178,
 190, 304–305
 topology of, 114–117
 using building blocks of, 108–111
 inventory, over a network, 259–260
 IP clouds, described, 123
 IPTalk, 176
 IRMA, terminal emulation, 220–221
 IRMALAN/EP Gateway, 216
 ISDN costs, 302–303
 ISDN (integrated services digital
 network), 286, 300–304
 connecting Macs to, 303
 ISDN NB Card, 303
 ISDN1 standard, 301, 304
 IS (information system) software
 systems, 245
 ISM (Industrial, Scientific and
 Medical) frequency range, 94

J

jabbering, defined, 268

JetLink Express, as Mac-to-PC-printer
 connector, 27, 31

K

K-AShare, 182
 Kermit file transfer protocol, 45
 keyboard mapping, 195, 218
 Kinetics Internet Protocol (KIP), 176,
 293–294
 K-Spool, 182

L

LAN-based e-mail systems, 147
 LAN (Local Area Network), defined,
 78
 LAN Manager, as PC network, 26
 LAN ONE fiber-optic product line, 91
 LANRES/VM (LAN Resource
 Extension and Services/VM), as
 client-server solution, 227
 Lan-Rover, in use with AppleTalk
 Remote Access, 61
 LAN Server, as PC network, 26
 LanWay card, 216
 laptops, 57–58
 carrying cases, 70
 DOS, 72–74
 software for, 65–69
 LaserJet laser printer, as common PC
 printer, 26, 29
 LaserJet PCL (printer command
 language), 31
 LaserWriter, 2
 LaserWriter Chooser, as system
 extension service, 130
 LAT (Local Area Transport) tool, 189
 Lau, Raymond, 46
 Liaison, as software router, 120
 lines
 digital and phone for WAN links,
 297
 T1, 298
 T3, 298
 Local Area Network (LAN), defined,
 78
 Local Area Transport (LAT) tool, 189

- local internets, 286
- LocalPeek, 280
- LocalTalk
 - as Macintosh network transmitting and receiving hardware, 23, 62, 80–81
 - for PC printers, 28–29
- looking ahead to OCE applications, 325–328
- LRP Print Server, 180
- LU 6.2/PU 2.1 protocol, 226

- M**
- MacAccess, 149–150
- Mac-accessible database servers, 237–241
- MacAPPC (Macintosh Advanced Program-to-Program Communications), 226–227
- MacBinary, as file format for file transfers, 45, 218
- MachTen, 165, 168–170
- Mac IIci, 153–154
- Mac IIfx, 154
- Macintosh Advanced Program-to-Program Communications (MacAPPC), 226–227
- Macintosh PC Exchange, 12
- MacIRMA Developers Toolkit, 224
- MacIRMAtrac card, 216
- MacIRMAtrac Fiber, 91
- MacLAN Connect
 - as file server enabler, 24
 - as gateway between networks, 26
- MacLinkPlus/PC, as file translation software, 14, 17, 18, 62
- MacMainFrame 3270 terminal emulation, 211–212, 214, 219
- MacMainFrame Graphics, 220
- MacMainFrame Programmers Toolkit, 224
- Mac Modem Port, 34–35
- MacODA translator, 308–309
- MacOSI transport, 307
- MacPrint, as Mac-to-PC-Printer connector, 27, 30–31
- MacPROFF, 222–223
- Mac Quadra, 79, 82, 154
- Macs, connecting to ISDN, 303
- Mac servers, 238–239
- Macs on TCP/IP, 176–177
- MacTCP, 176, 178
- Mac320, Mac330 & Mac340 terminal emulators, 197
- MacToken, 280–281
- Mac-to-Mac NetWORKS, 269
- Mac-to-Mainframe products, 347–349
- Mac-to-PC products, 329–331
- Mac-to-UNIX gateway, 182–183
- Mac-to-UNIX products, 344–345
- Mac-to-VAX/VMS products, 345–347
- MacUser*, 48, 329
- MacVonk, address of, 354
- MacWEEK*, 48, 329
- MacWorld*, 51, 329
- MacWorld Online, 51
- MacX25 software, 306
- MacX
 - in A/UX, 167
 - as an X Window Server, 172–173
- Magnum Software, address of, 332
- Mailbox, 315, 320
- MAILbus products, 204
- Mailer, 320–322
- MailMate, 205
- mail and messaging, using, 319–322
- mail/messaging services, of OCE, 315
- mail packages, for Mac and VAX systems, 204–207
- mainframe connections, 209–229
- mainframes, client-server computing in environment, 225–228
- Mainstay, address of, 340
- Make Changes setting, in AppleShare, 139
- management information base (MIB), 272
- MapInfo Corporation
 - address of, 350
 - MapInfo, 244
- mapping, topological, 262
- maps, geographic, 244
- Mariette Systems International
 - address of, 348
 - MacPROFF, 222–223

- Mass Micro, MASS 24/96, 63
- MAUG (Micronetworked Apple Users' Group), 48
- MAU (multistation access unit), for token rings, 85, 92–93
- MAXDATA technology, 219
- MaxNotes, 205
- MCI, 51
 - CommGate/MS & CommGate/QM, 150
- MCI Mail, address of, 334
- media
 - carrier, 295–304
 - as signal carriers, 86–95
- MediaWorks
 - Executive Workstation, 223
- Meeting Maker, 151
- Message Handling Service (MHS), 149–150, 319
- message transfer agent (MTA), 307
- messaging, 322
 - defined, 315
- metadata, in VITAL system, 249
- MIB (management information base), 272
- Microcom
 - address of, 333, 336
 - Carbon Copy Mac, 66, 174, 258
 - Cellular Data Link, 65
 - MNP (Microcom Networking Protocols), 37, 3
- Micronetworked Apple Users' Group (MAUG), 48
- Microphone II, 43, 44
- Microphone SmartCom, 14
- Microsoft
 - address of, 340, 351
 - LAN Manager, 26
 - Mail, 148–149
 - Rich Text Format (RTF), 15
 - Windows, 10
 - Word, 74
 - Works, 68
- Micro Times*, 47
- MicroVAX, 188
- midrange computers, 228
- MILNET, 178
- minicomputers, described, 188
- Mirammar Software
 - address of, 331
 - MacLAN Connect, 24, 26
- mirroring, disk, 158
- Mitem Corp.
 - address of, 348–349
 - Mitem View, 224, 225
 - Mitem Vision, 223
 - WHOOOP, 225
- MIT X Consortium, 171
- MNP (Microcom Networking Protocols), 37, 38, 64
- Mobidem Portable Wireless Modem, 73
- modem port on Macintosh, 34–35
 - connectors for, 35
- modems. *See also* telecommunications
 - cables for, 38
 - cellular, 64–65
 - creating an inexpensive adaptor cable, 38
 - data compression in, 36, 37–38
 - defined, 34, 35
 - error correction in, 36, 37–38
 - fax, 39–41, 64
 - network, 41
 - protocols, 36–38
 - recommended speeds, 35–36
 - for the road, 38
 - use of in hotels, 69
- modems and fax modems, 333–334
- modulation protocols, 37
- monitoring
 - device status, 269–270
 - networks, 266–273
 - with SNMP, 271–273
 - traffic, 267–268
- monitors. *See also* displays
 - switching off to save energy, 256
- Motif, 167, 171
- Motorola, Inc.
 - address of, 342
 - Altair, 95
 - NewsStream, 73
- MTA (message transfer agent), 307
- multi-access network gateways, 216–218
- multiplatform networks, 22–23
- multistation access unit (MAU), for token rings, 85, 92–93

- multitasking
 - lack of true in Mac operating system, 156
 - preemptive, 156
- Muse, 244
- N**
- Name Binding Protocol (NBP), 275
- NAS (Network Application Support)
 - network architecture, 200–201, 245
- National Semiconductor, address of, 338
- Navigator, as front-end to
 - CompuServe, 49–50
- NBP (Name Binding Protocol), 275
- NCSATelnet, as telnet provider, 178
- Neon Software
 - address of, 354
 - NetMinder LocalTalk & NetMinder Ethernet products, 280, 281
 - RouterCheck, 2.0, 272–273
- NetAtlas, 262
- NetDistributor, 264–265
- NETFinder, 182
- NetMinder Ethernet, 280, 281
- NetMinder LocalTalk, 280
- NetModem series, for network modems, 41, 122
- NetMounter, 158
 - as way to network Macintosh with PCs, 25
- NetRenderMan, 152–153
- NetScope Console, 268
- NetScope Probe, 268
- NetSerial, as network serial device connector, 29, 146
- NetWare
 - for Macs, 157–158
 - as Novell network, 22, 25, 157–158
- NetWare/SQL, 239
- NetWare 386 Services for SAA, 216–217
- Net Watchman, 270
- Netway 2000 gateway, 216
- Network Application Support (NAS)
 - network architecture, 200–201, 245
- Network General
 - address of, 354
 - Sniffer, 282–283
- Network Identity, as section of Sharing Setup control panel, 135
- networking, VAX and Mac, 190–193
- network management software, 254
- network management tools, 352–355
- network management and troubleshooting tools, 253–283
- network modems, 41
- network number conflicts, resolution of, 291–292
- network numbers
 - assignment of, 125–126
 - clustering of, 292
- network plumbing, 77–103
- network products, 336–339
- Network Resources Corp., address of, 338
- networks. *See also* connectivity; internets
 - arranging nodes in, 113
 - backing up over, 255–257
 - digital, 286, 300–304
 - dividing, 113–114
 - DOS on Mac via, 21–22
 - global, 285–309
 - helping users over, 255–258
 - infrared, 92–93
 - monitoring, 266–273
 - radio frequency (RF), 93–95
 - taking inventory over, 259–260
 - traffic of, 112, 267–268
 - upgrading, 114, 126
 - wireless, 91–95
- network services, 22, 129–160
- products, 340–341
- Network SuperVisor & Network SuperVisor TE, 262
- Network Vital Signs, 270, 271
- network volumes, shared, 142
- new network services, 151–153
- NEWS RISC-based workstation, 182

- NewsStream, as infrared port, 73
 - NFS file servers, as AFP servers, 179–183
 - NFS (Network Filing System), and Macs, 170, 180–181
 - NFS/Share, 180–181
 - Nisus Compact, 68
 - node addressing, dynamic, 112
 - node numbers, in networks, 72
 - nodes
 - arrangement of, 113
 - available on AppleTalk, 107
 - defined, 78
 - NonStop SQL databases, 241
 - Norton Utilities for the Macintosh, 155
 - Notebook, as Mac-compatible laptop, 57, 58, 62, 66
 - Notify!, 73, 262, 270, 273
 - Novell Inc.
 - Access Server, 22
 - address of, 341, 349
 - DataClub, 135, 144–146
 - DataClub Elite, 146
 - Global Messaging Server, 319
 - Message Handling Service (MHS), 149–150, 319
 - NetWare, 22, 25, 157–158
 - NetWare/SQL, 239
 - NetWare 386 Services for SAA, 216–217
 - 3270 LAN Workstation, 221
 - Now Software
 - address of, 341
 - Now Up-To-Date, 151, 152
 - NSFNet, 178
 - NuBus, 85
- O**
- Occam Co.
 - Muse, 244
 - OCE. *See* Open Collaboration Environment (OCE)
 - OCE directories, defined, 314
 - OCE Mailer, 315
 - OCR (Optical Character Recognition), in use with fax modems, 39
 - ODA (open document architecture), 308–309
 - ODI (Open Data Interchange) driver, as standard for PC network board office productivity applications, 242
 - off-the-shelf front-end solutions, 222–223
 - Omnis, 150, 224, 242
 - on-line services, 47–54, 334–335
 - On Technology
 - address of, 354
 - Meeting Maker, 151
 - Status•Mac, 260–261, 264, 266
 - Open Collaboration Environment (OCE), 150, 249, 312–328
 - and AppleTalk, 318–319
 - applications of, 325–328
 - authentication and privacy services of, 316
 - digital signature services of, 316, 326
 - Directory Browser, 314–315
 - directory services of, 313–315
 - mail/messaging services of, 315
 - using directories of, 316–319
 - in workgroups and workflow, 328
 - open document architecture (ODA), 308–309
 - Open Look, 171, 182
 - Open Software Foundation
 - Motif, 171
 - Open Systems Interconnection (OSI), 274–275, 276, 277, 286, 304
 - operating systems, 6
 - integrated PC-based network, 157–159
 - Oracle Corp.
 - address of, 351
 - ORACLE Server, 239
 - Orange Micro
 - address of, 331
 - Grappler, 27, 278
 - Orange386 board, 19–21
 - OS/2, 10
 - OSI (Open Systems Interconnection), 274–275, 276, 277, 286, 304
 - Outbound Systems, Inc.
 - address of, 336
 - Notebook, 57, 58, 62, 66

Pocket Port, 63
 outgrowing a Mac Server, 156–160
 out-of-band signaling, 301–302
 overhead traffic, 112

P

Pacer Forum, as LAN-based bulletin board, 151
 PacerFT file transfer protocol, 197
 Pacer Software, Inc.
 address of, 346, 351
 PacerConnect, 197
 PacerFT file transfer protocol, 197
 PacerLink, 197–199
 PacerPrint, 203
 PacerShare, 160, 200, 203
 PacerTerm, 178, 197–199
 packet analyzers (packet pokers), 254, 279–283
 packet assembler/disassembler (PAD), 306
 packets
 control, 278
 data, 278–279
 defined, 82, 278
 poking with hardware, 281–283
 poking with software, 279–281
 packet slicing, described, 280
 packet switching, X.25, 305–306
 PAD (packet assembler/disassembler), 306
 Paged Memory Management Unit (PMMU) chip, 165–166, 169
 palmtops, 73
 PAP (Printer Access Protocol), 278
 Paragon, Nisus Compact, 68
 passive stars, 97
 passwords, in AppleShare, 138
 Pathway Client NFS, 180
 PathWorks, 160, 179
 as complete VAX networking environment, 200–203
 mail features of, 204
 PC-based network operating systems, integrated, 157–159
PC Magazine, 49
 PC servers, 239
PC Week, 49
 People Finder utility, in AlisaMail, 206
 personal information managers (PIMs), 326–327
 phone lines, as least secure carrier for WAN links, 297
 PhonePro, 327
 PhotoLink, 92
 Photonics Corp.
 address of, 342
 PhotoLink, 92
 physical layer, in protocol stack, 275
 PIMs (personal information managers), 326–327
 Pixar, NetRenderMan, 152–153
 Planet X, 175
 PMMU (Paged Memory Management Unit) chip, 165–166, 169
 Pocket Port, 63
 poking packets with hardware, 281–283
 poking packets with software, 279–281
 portable computing products, 335–336
 Portfolio Systems, Dynodex, 3.0, 69, 326–327
 Post Office, in cc:Mail, 149
 Postscript, 29–30
 PowerBook, 57–58, 70–71
 peripherals for, 61–62
 PowerPC, 168
 PowerPort/v.32, 64
 preemptive multitasking, 156
 Printer Access Protocol (PAP), 278
 printer languages, 29–31
 printers, inkjet, 62
 printing, utilizing PC printers for Macintosh, 26, 27
 PrintMonitor, 130, 131–132, 135
 Print Server, in AppleShare, 143
 print services, 146–147
 print sharing devices, 28
 print spooler, 143, 155, 202
 privileges, access, 132, 138
 Prodigy, 52
 Prodigy Services Company, address of, 335
 productivity applications, office, 242
 productivity software, 68–69
 profile, defined, 260

PROFS/Office Vision, 222–223
 Program Linking, 136
 Prometheus Products, Inc., address of, 334
 proprietary network protocols, 157
 protocol analyzers, 274–283
 protocol converters, 214–215, 228
 protocol overhead, defined, 83
 protocols
 AARP (AppleTalk Address Resolution Protocol), 275
 ADSP (AppleTalk Data Stream Protocol), 278
 AEP (AppleTalk Echo Protocol), 277
 ASP (AppleTalk Session Protocol), 278
 ATalkAD (AppleTalk Administration Daemon), 294
 ATP (AppleTalk Transaction Protocol), 277
 AURP (Apple Update-based Routing Protocol), 286–289
 CCITT X.25, 286
 DDP (Datagram Delivery Protocol), 275, 278
 defined, 36, 78
 file transfer, 45, 195
 Frame Relay, 298
 internet-enabling, 107
 KIP (Kinetics Internet Protocol), 176, 293–294
 LU 6.2/PU, 2.1, 226
 modem, 36–38
 modulation, 37
 NBP (Name Binding Protocol), 275
 OSI versus TCP/IP, 304–305
 PAP (Printer Access Protocol), 278
 proprietary network, 157
 routing non-AppleTalk, 123
 RTMP (Routing Table Maintenance Protocol), 275
 third, 184–185
 update-based routing, 291
 X.25, 298
 ZIP (Zone Information Protocol), 275
 protocol stack, 275

punch-down blocks, 96, 98

Q

Quadra. *See* Mac Quadra
 query, defined, 231
 query applications, specialized, 242–244
 query languages, as accessor of
 database servers, 232, 234–236
 QuickDraw, as Mac drawing language, 30–31
 QuickMail, 148–149, 178, 315
 Quorum Software, 175
 address of, 344
 Quorum Equal, 170
 Quorum Latitude, 170

R

Racal Datacom, address of, 338
 Radar, 262, 263, 265
 radio frequency (RF) communication, 93–95
 RAM, cost and power consumption on laptops, 68
 rasterization, 41
 RC4 encryption algorithm, 324
 Reading DOS Disks, 10–11
 Reduced Instruction Set Chip (RISC), 168
 on routers, 119
 reducing router hops, 292–293
 reducing WAN router traffic, 291
 redundant routing, 117
 removable storage media, 13–14
 RenderPro, 152
 repository, in VITAL system, 249–250
 ResEdit, 13
 resistors, terminating, 62
 resolving network number conflicts, 291–292
 resource filtering, 119
 responder files, 272
 responder system extension, in use
 with inventory programs, 259, 266
 Retrospect Remote, 255, 257
 RF (radio frequency) communication, 93–95

- rights, user's versus network manager's, 265–266
 - RISC (Reduced Instruction Set Chip), 168
 - on routers, 119
 - RISC servers, 152–153, 159–160
 - RJ-11 connector, 88
 - RJ-11 jack, for use with modems, 64, 69–70
 - RJ-45 connector, 88
 - rooted and rootless windows, 173
 - RouterCheck, 2.0, 272–273
 - router hops, reduction of, 292–293
 - routers, 109. *See also* bridges; gateways
 - AURP, 294
 - danger of with Macintosh, 121
 - described, 106
 - exterior, 294
 - features of, 119–120
 - half-, 122
 - installation of, 124–126
 - for the Mac, 120–121
 - for a PC, 121
 - placement of, 114–117
 - selection of, 119–123
 - smart, 272
 - software for, 120–121, 124
 - upgrading strategies for, 126
 - routing
 - AURP, 291
 - redundant, 117
 - WAN, 289–295
 - routing non-AppleTalk protocols, 123
 - Routing Table Maintenance Protocol (RTMP), 275
 - RSA Data Security, Inc., 323
 - RSA public key encryption, 323
 - RTMP (Routing Table Maintenance Protocol), 275
 - RunPC, as network provider of DOS, 21–22
 - RunPC/Remote, as file translation software, 14
- S**
- SAA (System Application Architecture), 211, 245
 - Salient Software
 - address of, 332
 - AutoDoubler, 47
 - SAS/Graph, 221
 - satellite communications, 298–300
 - satellite delay, 299
 - screen-sharing software, 66–68, 258
 - scripting, for simplifying repetitive tasks, 44
 - SCSI disk mode, for PowerBooks, 62
 - SCSI emulation, for Outbound Notebook, 62
 - SCSI port, defined, 34
 - SDLC (Synchronous Data Link Control), 214, 215
 - SE/30, Macintosh, 153
 - security
 - on AppleTalk Remote Access, 60
 - employing, 323–325
 - See* Files setting, in AppleShare, 139
 - See* Folders setting, in AppleShare, 139
 - self-extracting archives, 47
 - self-terminating cable, 96
 - serial connections, between Mac and PC, 14
 - Serial Link Internet Protocol (SLIP), in UNIX, 168, 170, 178
 - server backup medium, DAT (digital audio tape), 156, 255
 - Server platform, using the Mac as a, 153–156
 - servers
 - DAL, 236
 - database, 151, 234
 - display, 171
 - distributed processing, 152
 - Mac, 153–155, 238–239
 - PC, 239
 - RISC, 152–153, 159–160
 - VAX, 159–160
 - X, 134, 171
 - server storage, 155–156
 - service access modules, in System, 7, 313
 - services
 - network, 129–160
 - new network, 151–153
 - on-line, 47–54

- using third-party Mac, 144–153
- Shannon's Law, as limit on modem transmission speed, 36
- shared network volumes, 142
- shareware, 42–43
- sharing files with PCs, 10
- Sharing Setup control panel, 135–136
- Sharp Wizard, 73–74
- shells. *See* command shells
- Shiva Corporation
 - address of, 336, 338, 343
 - FastPath, 176, 192
 - Lan-Rover, 61
 - NetModem series, 41, 122
 - NetSerial, 29, 146
- shopping for ISDN, 301–303
- shutdown warning, 142–143
- signaling, out-of-band, 301–302
- Silicon Graphics
 - Indigo, 152–153
- SimMac, as terminal emulator, 221, 224, 225
- Simple Mail Transfer Protocol (SMTP), 170, 178, 305
- Simple Network Management Protocol (SNMP)
 - and AppleTalk, 254–255, 267
 - and intelligent hubs, 101
 - monitoring with, 271–273
 - and routers, 119
- SIM3278 protocol converter, 214
- SimVision, 222–223
- Simware
 - address of, 349
 - SimMac, 221, 224, 225
 - SimVision, 222–223
- SimXfer, 221
- Sitka Corporation
 - address of, 341
 - TOPS, 134
 - TOPS FlashTalk card, 23
- sleep mode, on laptop Macs, 71–72
- SLIP (Serial Link Internet Protocol), in UNIX, 168, 170, 178
- Smartcom II, 43, 44
- smart hubs and routers, 272
- SMDS (switched multimegabit data service), 298
- SMTP (Simple Mail Transfer Protocol), 170, 178, 305
- SNA•ps Gateway, 218
- SNA•ps (Systems Network Architecture protocols and services), 110, 192, 219
- SnapBack, 255, 256–257
- SNA (Systems Network Architecture), 210–211
- Sniffer, 282–283
- SNMP (Simple Network Management Protocol)
 - and AppleTalk, 254–255, 267
 - consoles, 272
 - hardware, 272
 - and intelligent hubs, 101
 - monitoring with, 271–273
 - network management software for, 272
 - and routers, 119
 - software, 272–273
- sockets, defined, 268
- SoftNode, as way to network Macintosh with PCs, 25
- SoftPC, as DOS emulator, 18–19
- software
 - asset management, 259–260
 - choosing client, 241–244
 - compatibility between platforms, 6
 - connectivity, 66
 - device monitoring, 254
 - file translation, 10, 14, 15–18
 - front-ending host, 221–225
 - installation of, 258
 - installation of, over a network, 263–265
 - installation of router, 124
 - installer programs, 265
 - for laptops, 65–69
 - network management, 254
 - packet analyzers, 279–281
 - productivity, 68–69
 - protocol analyzers, 274
 - screen-sharing, 66–68, 258
 - SNMP, 272–273
 - telecommunications, 41–45
 - upgrade packages for, 263–265
 - X client, 17

- Software Bridge, 17, 66
- software routers, 120–121
- software systems, IS (information system), 245
- Software Ventures, Inc.
 - address of, 332
 - Microphone II, 43, 44
- Sonic Systems
 - address of, 338, 354
 - Radar, 262, 263, 265
- Sony, NEWS RISC-based workstation, 182
- SpaceMaker, 47
- spanning, described, 156
- Spider Island Software, address of, 333
- spooler, print, 143, 155, 202
- spooling, defined, 130
- spread-spectrum modulation, in ISM transmissions, 94, 95
- SQL (structured query language), 202, 227, 232
- Stallion NuBus card, 86
- standardizing WAN routing, 293–294
- Standard Microsystems, address of, 336
- star hubs, 88, 98, 100, 101
- StarNine Technologies, Inc., address of, 341
- stars
 - active, 98–99
 - passive, 97
- star topology, 96, 99, 116
- Status•Mac, 260–261, 264, 266
- S/36 & S/38 minicomputers, 228
- store-and-forward architecture
 - in AlisaMail, 205
 - in All-in-1 Mail, 204
 - defined, 135
 - and e-mail servers, 147
 - and OCE, 312, 313, 320, 322
 - and Status•Mac, 261
- storms, defined, 120
- Strata
 - RenderPro, 152
 - StrataVISION 3d, 152
- StrataVISION 3d, 152
- Strategic Mapping, Inc.
 - address of, 351
 - Atlas Pro, 244
- StreetTalk, 315
- StreetTalk Global Directory Service, in VINES, 159
- structured query language (SQL), 202, 227, 232
- StuffIt, 46–47
- StyleWriter, 62
- Sun Microsystems
 - NFS (Network Filing System), 170, 179–183
 - Open Look, 171, 182
 - SPARC workstation, 239–240
- Sun Partner, 182
- SuperCard, as competitor of HyperCard, 224
- SuperDrive, 10–11
- SuperLaserSpool, 27, 146–147
- SWIM, 11
- Switched 56, 297–298
 - described, 297
- switched multimegabit data service (SMDS), 298
- Symantec
 - GreatWorks, 68
 - Norton Utilities for the Macintosh, 155
- Synchronous Data Link Control (SDLC), 214, 215
- Synergy Software
 - address of, 333, 344, 346
 - VersaTermPRO, 178, 196
- System Application Architecture (SAA), 211, 245
- System 6
 - communications and, 189
 - speed of on servers, 155
- System 7
 - database hooks of, 232–233
 - OCE and, 312–313
 - service access modules in, 313
 - speed of on servers, 155
 - tools and, 189
 - with UNIX, 165–166
 - upgrading to, 261
- systems infrastructure, of the VITAL system, 250

Systems Network Architecture
 protocols and services (SNA•ps),
 110, 192, 219
 Systems Network Architecture (SNA),
 210–211

T

Tactics International
 address of, 351
 Tactician, 244
 Tandem Co.
 Data Access Language Server, 241
 NonStop SQL databases, 241
 Tandem hosts, 240–241
 Transaction Monitoring Facility, 241
 TCP/Connect II, 177, 178
 TCP/IP Internet, 110, 123, 164, 168,
 175, 178
 TCP/IP networks, 175–178, 190, 290,
 304–305
 TCP/IP services, 177–178
 Team Advanced Systems Associates,
 Stallion NuBus card, 86
 TechGnosis, Inc., address of, 351
 TechWorks
 address of, 339, 354
 GraceLAN Asset Manager, 262
 GraceLAN Network Manager, 260,
 261–262, 266
 GraceLAN Update Manager,
 264–265, 266
 telecommunications, 33–55. *See also*
 modems
 inexpensiveness of, 34
 products, 332–335
 software, 41–45, 66
 Telenet, 178
 telephones and electronic mail, 327–328
 telephone wire, in networks, 86–88
 tellular box, 64–65
 telnet, as TCP/IP protocol, 178
 templates
 in the directory volume, 317
 in VITAL system, 250
 Tempo II, scripting features of, 44
 10BaseF & 10BaseT standards, 91

Tenon Intersystem
 address of, 345
 MachTen, 165, 168–170
 XTen, 169
 Teradata Co.
 CLient/Server for Macintosh, 241
 DBC/1012 Data Base Computer, 241
 terminal emulation, 43–44
 defined, 178
 IRMA, 220–221
 MacMainFrame, 3270, 211–212, 214,
 219
 Mac320, Mac330 & Mac340, 197
 products, 195–200
 3270 software, 218
 as way to access VAX applications,
 194–199
 terminating resistors, at end of SCSI
 chains, 62
 Text format, for transferring files, 45
 thicknet and thinnet, 88–89
 third-party Mac services, 144–153
 third-party mail and messaging,
 204–207
 third protocol, 184–185
 3270 LAN Workstation for Macintosh,
 221
 3278/9 terminals, 218
 Thomas-Conrad, Corp., address of, 336
 threads, in forums, 54
 throughput, in data link mechanisms,
 83–84
 Thursby Software Systems
 TSSnet, 193
 TIFF bit-mapped format, 16
 Timbaktu, 22, 66, 70, 174, 258
 tip and ring box, 64–65
 T/Maker, WriteNow, 68
 TN3270 terminal emulator, 219
 token passing, 83
 token ring
 cards for the Mac, 216
 networks, 83–85, 91, 107, 211,
 215–216
 products, 339
 tools for, 280–281
 TokenTalk driver, 85

TokenTalk NB card, 216
 T1 & T3 lines, 298
 tools
 as certain types of files, 189–190
 frame capture. *See* packet analyzers
 traffic monitoring, 254
 topological mapping, 262
 topology
 backbone, 101–102, 115–116
 bus, 96
 internets, 114–117
 star, 96, 99, 116
 TOPS, as third-party file server, 134
 TOPS FlashTalk card, as LocalTalk
 card for PCs, 23
 trackballs, 74
 traffic, 112
 monitoring, 267–268
 reduction of WAN router, 291
 traffic monitoring tools, 254
 TrafficWatchII, 268, 269
 transaction, in client sockets, 277
 Transaction Monitoring Facility, 241
 transfer software. *See* file transfer
 software
 translation software, 10, 14, 15–18
 Transport Gateway, AppleTalk-to-
 DECnet, 193
 Traveling Software
 address of, 331
 LapLink/Mac, 14
 Tribe Computer Works, address of, 339
 Trik, Inc.
 address of, 355
 NetDistributor, 264–265
 troubleshooting and network
 management tools, 253–283
 TrueType fonts, 41
 TSSnet, 193
 tunneling, 287
 described, 123
 tunnels, connecting, 294–295
 TwinAccess board, 228
 twisted-pair cabling, 86–88
 Tymnet, 178
 Type code, for extension mapping, 13

U

ULTRIX operating system, 188
 Ungermann-Bass, Inc., address of, 343
 universal driver formatter, 14
 UNIX, 6, 163–164
 as database server, 239–240
 as universal operating system,
 163–185
 UNIX hosts, as AFP file servers, 160,
 181–182
 UNIX to UNIX copy program (uucp),
 168, 170
 update-based routing protocols, 291
 upgrade packages, for software,
 263–265
 UShare, 182
 using the Mac as a server platform,
 153–156
 uucp (UNIX to UNIX copy program),
 168, 170

V

VAX, 187–207
 and AppleTalk, 190, 193
 as database server, 240
 electronic mail servers, 203–207
 as Mac file and print server, 200–203
 PathWorks as networking
 environment in, 200–203
 VAXcluster, 188
 VAX networking, and the Mac,
 190–193
 VAX Rdb/VMS database, 240
 VAX servers, 159–160
 VAXshare, 201, 202
 VersaTerm-PRO, 196
 as telnet provider, 178
 very small aperture satellite terminals
 (VSAT), 300
 v.42bis, modem and data compression,
 59–60
 VINES, as PC network, 25, 159
 virtual disks, 199
 virtual file server, as logical volume,
 144–145

Virtually Integrated Technical Architecture Lifecycle (VITAL), 232, 245–250

virtual terminal connection. *See* telnet

VITAL (Virtually Integrated Technical Architecture Lifecycle), 232, 245–250

VM operating systems, 227

VMS application access, 194–200

VMSmail, 203

VMS operating system, 188, 202

VSAT (very small aperture satellite terminals), 300

VT series terminal emulation, 194

W

waiting for ISDN, 303–304

Wall Street Journal, 51

WAN router traffic, reduction of, 291

WAN routing, 289–295
standardizing, 293–294

WAN (wide-area network), 285–286

Webster Computer Corporation, address of, 339, 346

White Knight
as communications software, 42
as file transfer package, 14

White Pine Software
address of, 345, 346–347
Mac320, Mac330 & Mac340 terminal emulators, 197

WHOOOP, as pattern-matching engine, 225

wide-area network products, 342–343

wide-area network (WAN), 285–286

windows, rooted and rootless, 173

wireless networking, 91–95

The Wollongong Group, Inc.
address of, 339, 345
Pathway Client NFS, 180

WordPerfect Corp.
address of, 341
LetterPerfect, 68
WordPerfect, 68, 74

workgroup applications, 151

workgroups, creation of, 113–114

workgroups and workflow, with OCE, 328

working with OCE-aware databases, 326–327

Workstation Data Save Facility/VL, 227

WriteNow, 68

X

X. See X Window System

X client software, 174–175

XCMD, as external command linked to HyperCard, 224

X11, as an X Window Server, 167, 174

XFCN, as external function linked to HyperCard, 224

X.500 directory standard, 314–315

X.400 mail, 307–308

XGator, 175

XiNET
address of, 345
K-AShare, 182
K-Spool, 182

XModem file transfer protocol, 45

X/OPEN Transport Interface (XTI), 307

X server, 171

XTen, 169

XTI (X/OPEN Transport Interface), 307

XTND, in file translation, 16, 17, 149, 308–309, 320

X.25 packet switching, 305–306

X.25 protocol, 298

X Window System
as DECwindows, 199–200
described, 167
and Mac operating system, 172
as means to access VMS Applications, 194
in UNIX GUIs, 164
and VAX, 188

Y

YModem file transfer protocol, 45

Z

ZiffNet/Mac. *See* ZMac

ZIP (Zone Information Protocol), 275

Zirco, Data Cell, 65

ZMac, 48–49

ZModem file transfer protocol, 45

Zone Information Protocol (ZIP), 275

zones

- creation of in networks, 117–118

- defined, 108

- limits on in AppleTalk Phase, 2, 118

Zterm

- as file transfer program, 14

- scripting features of, 44

Save More than \$15 on

MacUser

A fabulous deal for our readers!

You purchased this book to make the most of your Mac. Now, keep vital information coming throughout the year with MacUser. Subscribe today for great savings, plus...

- Comparative product reviews to tell you what's best for your needs and your budget
 - Up-to-the-minute features to keep you on top of this ever-changing business
 - Power-user tips and tutorials to boost your performance and productivity
- AND MUCH MORE!**



YES!

Send me 12 informative, value-packed issues of *MacUser* for only \$19.97—that's more than \$15 off the annual \$35.40 cover price.

NAME

(Please Print)

855Q6

COMPANY

ADDRESS

CITY

STATE

ZIP

Payment enclosed. Bill me later.

Basic one-year subscription \$27.00; on newsstands \$35.40. Canada and foreign add \$16.00. U.S. funds only. Canadian GST included. Please allow 30 days for shipment of first issue.



NO POSTAGE
NECESSARY
IF MAILED
IN THE
UNITED STATES

BUSINESS REPLY MAIL

FIRST CLASS MAIL PERMIT NO. 66 BOULDER, CO

POSTAGE WILL BE PAID BY ADDRESSEE

MacUser

P.O. Box 52461
Boulder, CO 80321-2461



MacUser

Guide to Connectivity

John Rizzo

John Rizzo keeps his finger on the pulse of the Macintosh universe as technical editor of *MacUser*. A popular *MacUser* writer and the author of over 150 articles, he has personally reviewed many of the products described in the book. He lives in San Francisco, California.

No Mac Is an Island . . .

Master and extend the built-in connectivity power of the Macintosh with this one-of-a-kind resource from *MacUser* technical editor John Rizzo. His easy-to-read style is ideal for just about anyone who needs to share information in a Macintosh environment—from Mac users venturing into connectivity for the first time to experienced managers looking to broaden their knowledge and sharpen their skills.

Rizzo meticulously covers every Macintosh connectivity feature and option and, armed with the results of benchmark tests conducted in the labs of *MacUser*, he makes detailed recommendations for all of your hardware and software needs. You'll become a more savvy shopper and increase your workplace productivity as you learn what's possible and what's worth your time and money in the ever-expanding realm of Macintosh connectivity.

Among the many topics covered in the book are . . .

- Sharing Macintosh files with PCs and printing to PC printers
- Traveling with your Powerbook—what to take along for maximum connectivity
- Setting up, managing, and troubleshooting a local area network
- Anticipating the 90s: Mac connectivity in the future
- Selecting and using network services, such as file sharing and electronic mail
- Connecting with UNIX, VAX, and mainframes

Whether you're interested in basic telecommunications, full-blown networks, or anything in between, you'll find the practical information and lab-tested advice you need in *MacUser Guide to Connectivity*.

Special MacUser Subscription Offer Inside

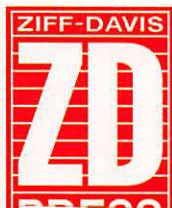

U.S. \$27.95
Canada \$35.95

BOOKSHELF CATEGORY
Apple/Networking

1-56276-056-4

SCAN
OTHER
SIDE

5 2 7 9 5 >

EAN



9 781562 760564